



**vision**LINE™

ACCESSORIES





# visionLINE™

---

VisionLINE designs, creates and manufactures premium quality fireplaces, venting systems and fireside accessories to meet the unique requirements in the Australian market.

Modern, cutting edge designs incorporated into durable and made to last products make your investment in VisionLINE products a lifetime relationship.



# THE MK2 OUTDOOR FIREPIT BY VISIONLINE

Add warmth and character to your backyard gatherings with the MK2 Outdoor Firepit by VisionLINE. Enjoy more flame with less smoke, as the unique dual wall and secondary combustion design creates a virtually smokeless fire.

The MK2 Firepit can be easily transported and positioned within your home thanks to the available carry bag and lightweight stainless steel. With style and durability our firepit is built to be used for hours on end.

Double shielded for reduced floor surface temperatures below the unit. Use only on Non-combustible flooring or stone.

The only outdoor firepit in Australia tested to Australian Standards for emissions (AS/NZS 4012.13) with emissions of 0.2g per 1kg of wood burnt – this makes the VisionLINE Firepit virtually smokeless.



OPTIONAL FIREPIT COVER

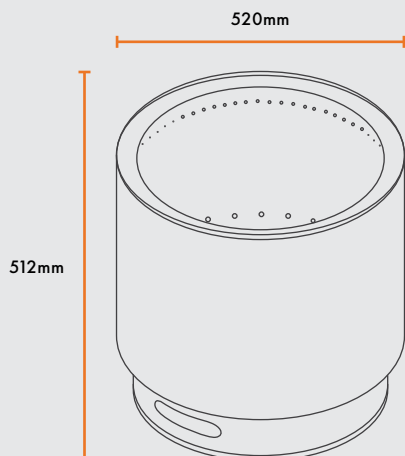

**FIREPIT DIMENSIONS**  
H 512mm | Ø 520mm

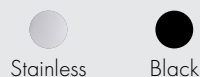



# PIZZA OVEN

Enjoy authentic wood fired pizza in a compact and ultra portable bench top design with the VisionLINE pellet fire pizza oven.

The VisionLINE pellet fire pizza oven reaches beyond 260°C super fast, so you can be cooking delicious stone-baked pizza within 15 minutes of lighting. Swap the pizza stone for the griddle plate and drip tray for a wood fired grilling experience. Pellets light easily in the rear burn basket leaving minimal ash behind.

Perfect for making pizza anywhere, the VisionLINE pizza oven has foldable legs and is lightweight enough to take on the go.



## PIZZA PACKAGE CONTAINS

- 1x Pizza stone
- 1x Pizza peel
- 1x Griddle plate, handle and drip tray
- Optional pellet scoop available

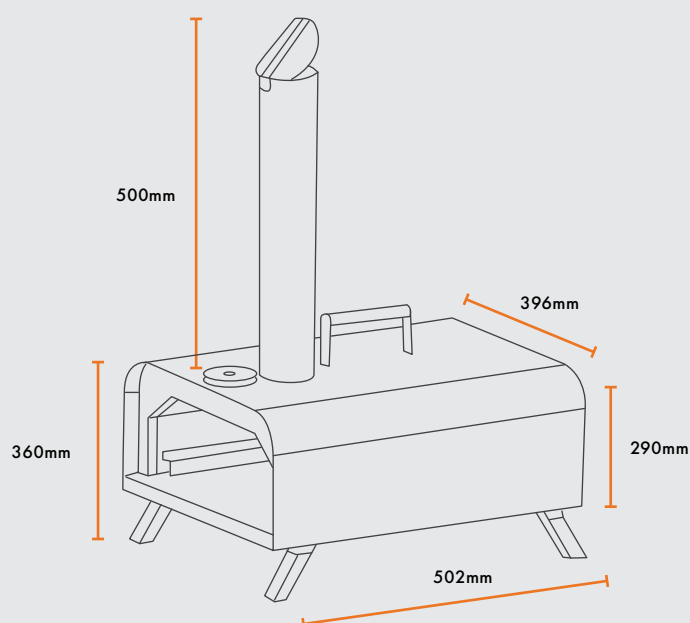

## PIZZA OVEN DIMENSIONS

H 290mm (360mm on legs) | W 396mm D 502mm | FLUE H 500mm







# STOVE TOP OVEN

The VisionLINE stove top oven gives you the ability to harness the heat of your radiant wood fire to create an oven to bake, just like in your oven in the kitchen.

The oven is made from stainless steel and finished in a durable powder coated finish.

It comes standard with a built in thermometer to give you total control over your cooking.

The VisionLINE stove top oven also comes with a stainless trivet which lifts you off the active surface. The trivet can also be used when cooking with a pan to give you less direct heat, such as a slow cook pot roast. This trivet can also be purchased as a separate item.



# STOVE TOP FAN

The VisionLINE stove top fan uses thermo energy from your radiant heater to generate an electric charge causing the fan blades to spin. Gently and quietly assists air movement without needing batteries or mains power.

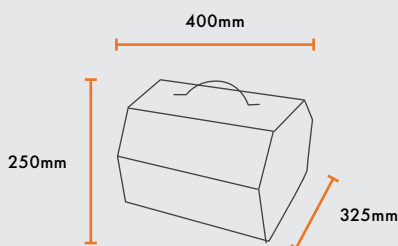

**OVEN SIZE**

H 250mm | W 400mm | D 325mm

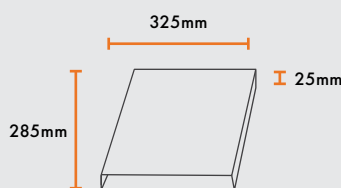

**TRIVET SIZE**

H 25mm | W 325mm | D 285mm

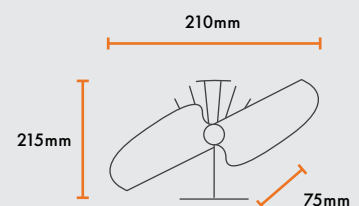

**FAN SIZE**

H 215mm | W 210mm | D 75mm



# WOOD STORAGE

Stylish and functional, the VisionLINE wood storage units offer modern design with the ease of having wood near your fireplace for when you need it most. Choose from a range of sizes and finishes for a versatile solution for both indoor and outdoor firewood storage.

- Easy to assemble
- Powder coated
- Large holding capacities



Stackable, create your own design

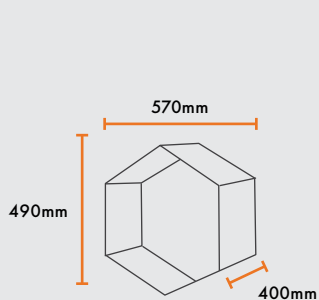

**HEXAGON STACKER (EACH)**  
H 490mm | W 570mm | D 400mm

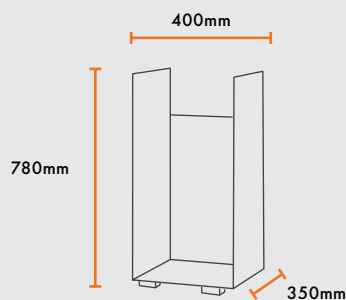

**RECTANGLE STACKER**  
H 780mm | W 400mm | D 350mm

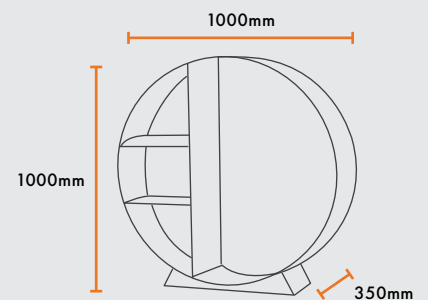

**CIRCULAR STACKER**  
H 1000mm | W 1000mm | D 350mm



## NOTES

---

---

---

---

---





---

---

---

---

---

---





VisionLINEFire.com.au



Designed in Europe & Australia



FIREWOOD ASSOCIATION  
OF AUSTRALIA INC™