

Owner's Manual

Operation & Care

INSTALLER: Leave this manual with party responsible for use and operation.

OWNER: Retain this manual for future reference.

Contact your dealer with question on installation, operation, or service.

NOTICE: DO NOT DISCARD THIS MANUAL

QUADRA-FIRE®

**2100 MILLENNIUM
AUSTRALIA
WOOD APPLIANCE
AUTOMATIC COMBUSTION CONTROL
(ACC)**

**MODEL:
21M-ACC-AU**

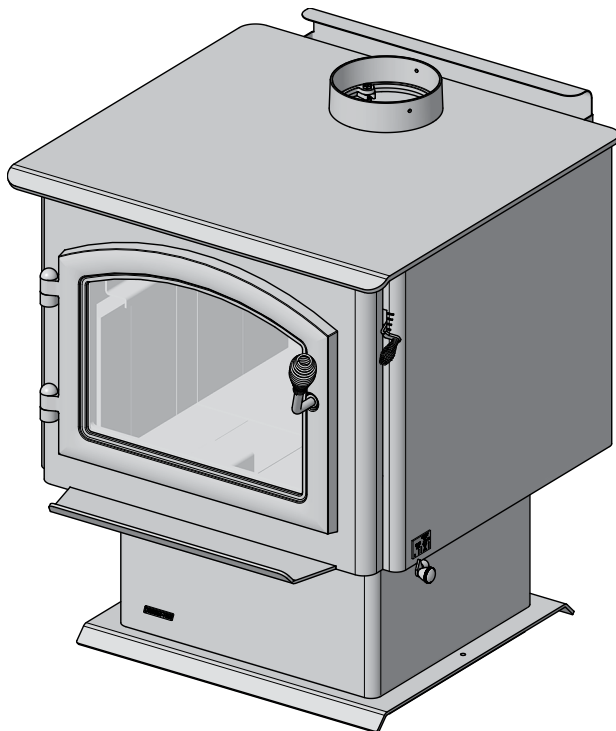

WARNING



If the information in these instructions is not followed exactly, a fire could result causing property damage, personal injury, or death.

- Do not store or use gasoline or other flammable vapors and liquids in the vicinity of this or any other appliance.
- Do not over fire - If appliance or chimney connector glows, you are over firing. Over firing will void your warranty.
- Comply with all minimum clearances to combustibles as specified. Failure to comply may cause house fire.



WARNING



HOT SURFACES!

Glass and other surfaces are hot during

operation AND cool down.

Hot glass and appliance will cause burns.

- Do not touch glass until it is cooled
- Use leather gloves when reloading fuel
- NEVER allow children to touch glass
- Keep children away
- CAREFULLY SUPERVISE children in same room as appliance.
- Alert children and adults to hazards of high temperatures
- High temperatures may ignite clothing or other flammable materials.
- Keep clothing, furniture, draperies and other flammable materials away.



WARNING



Fire Risk.

For use with solid wood fuel only.

Other fuels may over fire and generate poisonous gases (i.e. carbon monoxide).

NOTE: Clearances may only be reduced by means approved by the regulatory authority having jurisdiction

A. Sample of Serial Number / Safety Label

LOCATION: Back of appliance



MILLENNIUM ACC WOODFIRE COMPLIANCE LABEL

AU

This appliance has been TESTED TO AS/NZS4013 for Hardwood by HRL Technology Report #HCMG/12/014A - Date tested: March 2012

MODEL QUADRA-FIRE 2100 MILLENNIUM ACC FREESTANDING WOOD STOVE

OVERALL AVERAGE EFFICIENCY BURNING HARDWOOD
 WHEN TESTED IN ACCORDANCE WITH AS/NZS 4012: 87%
 AVERAGE PARTICULATE EMISSION FACTOR BURNING HARDWOOD
 WHEN TESTED IN ACCORDANCE WITH AS/NZS 4013: 2.2 g/dry kg
 MAXIMUM AVERAGE HEAT OUTPUT BURNING HARDWOOD: 7.8 kW
 APPROVED FUEL: BURN ONLY HARDWOOD WITH A MOISTURE CONTENT
 LESS THEN 25% (dry basis).
 Wetback - All Models: Wetbacks are NOT an approved option and must not be fitted.
 Manufactured By: Hearth & Home Technologies, 352 Mountain House Road,
 Halifax, PA 17032, United States of America

Serial No. /
N° de série: **HF**

BARCODE LABEL

Date of Manufacture / Date de fabrication:

2022	2023	2024	JAN	FEB	MAR	APR	MAY	JUN	JUL	AUG	SEP	OCT	NOV	DEC
■	■	■	■	■	■	■	■	■	■	■	■	■	■	■

7039-148F

NOTE: PERFORMANCE MAY VARY FROM TEST VALUES DEPENDING ON ACTUAL OPERATING CONDITIONS.
 U.S. ENVIRONMENTAL PROTECTION AGENCY
 Export stove. May not be operated within the United States

INSTALLATION
 DATE: ___/___/___

Test Lab & Report No.

Serial No.

Model Name

Mfg. Date



Safety Alert Key:

- **DANGER!** Indicates a hazardous situation which, if not avoided will result in death or serious injury.
- **WARNING!** Indicates a hazardous situation which, if not avoided could result in death or serious injury.
- **CAUTION!** Indicates a hazardous situation which, if not avoided, could result in minor or moderate injury.
- **NOTICE:** Indicates practices which may cause damage to the appliance or to property.

TABLE OF CONTENTS

A. Sample of Serial Number / Safety Label	2	4 Troubleshooting Guide	18
B. Warranty Policy	4	5 Service Part Replacement	
C. Quick Start Guide.	6	A. Glass Replacement - Door Assembly	19
1 Listing and Code Approvals		B. Firebrick Replacement	19
A. Appliance Certification	7	C. Door Handle Assembly	19
B. BTU & Efficiency Specifications	7	D. Baffle Removal	20
C. Glass Specifications.	7	E. Tube Channel Assembly Replacement	21
2 Operating Instructions		6 Reference Materials	
A. Over-Firing Your Appliance	8	A. Service and Maintenance Log	22
B. Wood Selection & Storage	8	B. Service Parts	24
C. Burning Process.	8		
D. Air Controls	9		
E. Using Burn Rate Air Control & ACC System	9		
F. Burn Rates and Operating Efficiency	10		
G. Building A Fire	11		
H. Correct Baffle & Blanket Placement.	12		
I. Opacity (Smoke)	13		
J. Clear Space	13		
K. Negative Pressure	14		
L. Frequently Asked Questions.	14		
3 Maintenance and Service			
A. Quick Reference Maintenance Guide	15		
B. General Maintenance.	16		

→ = Contains updated information

B. Warranty Policy



AUSTRALIAN WARRANTY INFORMATION

Hearth & Home Technologies Inc (HHT)
352 Mountain House Road | Halifax, PA 17032 | (717-362-9080)

HHT extends the following manufacturer's warranty for HHT gas, wood, pellet, coal and electric hearth appliances that are purchased from an HHT authorized dealer.

HHT warrants to the original owner of the HHT appliance at the site of installation, and to any transferee taking ownership of the appliance at the site of installation within two years following the date of original purchase, that the HHT appliance will be free from defects in materials and workmanship at the time of manufacture.

After installation, if covered components manufactured by HHT are found to be defective in materials or workmanship during the applicable warranty period, HHT will, at its option, repair or replace the covered components. HHT, at its own discretion, may fully discharge all of its obligations under this manufacturer's warranty by replacing the product itself or refunding the verified purchase price of the product itself. The maximum amount recoverable under this warranty is limited to the purchase price of the product. This warranty is subject to conditions, exclusions and limitations as described below.

Warranty coverage begins on the date of original purchase. In the case of new home construction, coverage under this manufacturer's warranty begins on the date of first occupancy of the dwelling or six months after the sale of the product by an independent, authorized HHT dealer/ distributor, whichever occurs earlier. The warranty period for this manufacturer's warranty shall commence no later than 24 months following the date of product shipment from HHT, regardless of the installation or occupancy date. The manufacturer's warranty period for parts and labor for covered components is produced in the following table.

The term "Limited Lifetime" in the table below is defined as: 20 years from the beginning date of warranty coverage for gas appliances, and 10 years from the beginning date of warranty coverage for wood, pellet and coal appliances. These time periods reflect the minimum expected useful lives of the designated components under normal operating conditions.

Warranty Period		Hearth and Home Technologies Manufactured Appliances and Venting							Components Covered
Parts	Labor	Gas	Wood	Pellet	EPA Wood	Coal	Electric	Venting	
1 Year		X	X	X	X	X	X	X	All parts and material except as covered by Conditions, Exclusions, and Limitations listed
2 years				X	X	X			Igniters, electronic components, and glass
		X	X	X	X	X			Factory-installed blowers
			X						Molded refractory panels
3 years				X					Firepots and Burnpots
5 years	1 year			X	X				Castings and baffles
7 years	3 years		X	X	X				Manifold tubes, HHT chimney and termination
10 years	1 year	X							Burners, logs and refractory
Limited Lifetime	3 years	X	X	X	X	X			Firebox and heat exchanger
90 Days		X	X	X	X	X	X	X	All replacement parts beyond warranty period

OTHER RIGHTS

The HHT manufacturer's warranty is in addition to other rights and remedies that you may have under Australian law.

Our goods come with guarantees that cannot be excluded under the Australian Consumer Law. You are entitled to a replacement or refund for a major failure and for compensation for any other reasonably foreseeable loss or damage. You are also entitled to have the goods repaired or replaced if the goods fail to be of acceptable quality and the failure does not amount to a major failure.

WARRANTY CONDITIONS AND EXCLUSIONS:

- The HHT manufacturer's warranty only covers HHT appliances that are purchased through an HHT authorized dealer or distributor. A list of HHT authorized dealers is available on the HHT branded websites.
- This warranty is only valid while the HHT appliance remains at the site of original installation.

WARRANTY EXCLUSIONS:

This HHT manufacturer's warranty does not cover the following:

- Changes in surface finishes as a result of normal use. As a heating appliance, some changes in color of interior and exterior surface finishes may occur. This is not a flaw and is not covered under warranty.
- Damage to printed, plated, or enamelled surfaces caused by fingerprints, accidents, misuse, scratches, melted items, or other external sources and residues left on the plated surfaces from the use of abrasive cleaners or polishes.
- Repair or replacement of parts that are subject to normal wear and tear during the warranty period. These parts include: paint, wood, pellet and coal gaskets, firebricks, grates, flame guides, light bulbs, batteries and the discoloration of glass.
- Minor expansion, contraction, or movement of certain parts causing noise. These conditions are normal and complaints related to this noise are not covered by this warranty.
- Damages resulting from: (1) failure to install, operate, or maintain the appliance in accordance with the installation instructions, operating instructions, and listing agent identification label furnished with the appliance; (2) failure to install the appliance in accordance with local building codes; (3) shipping or improper handling; (4) improper operation, abuse, misuse, continued operation with damaged, corroded or failed components, accident, or improperly/incorrectly performed repairs; (5) environmental conditions, inadequate ventilation, negative pressure, or drafting caused by tightly sealed constructions, insufficient make-up air supply, or handling devices such as exhaust fans or forced air furnaces or other such causes; (6) use of fuels other than those specified in the operating instructions; (7) installation or use of components not supplied with the appliance or any other components not expressly authorized and approved by HHT (8) modification of the appliance not expressly authorized and approved by HHT in writing; and/or (9) interruptions or fluctuations of electrical power supply to the appliance.
- Non HHT venting components, hearth components or other accessories used in conjunction with the appliance.
- Any part of a pre-existing fireplace system in which an insert or a decorative gas appliance is installed.
- Removal, installation, reinstallation, set up or any other costs associated with a claim including travel and shipping charges for parts.
- HHT's obligation under this warranty does not extend to the appliance's capability to heat the desired space. Information is provided to assist the consumer and the dealer in selecting the proper appliance for the application. Consideration must be given to appliance location and configuration, environmental conditions, insulation and air tightness of the structure.

This warranty is void if:

- The appliance has been over-fired or operated in atmospheres contaminated by chlorine, fluorine, or other damaging chemicals. Over-firing can be identified by, but not limited to, warped plates or tubes, rust coloured cast iron, bubbling, cracking and discoloration of steel or enamel finishes.
- The appliance is subjected to prolonged periods of dampness or condensation.
- There is any damage to the appliance or other components due to water or weather damage which is the result of, but not limited to, improper chimney or venting installation.

HOW TO CLAIM

- To make a claim against this warranty, contact your local distributor during regular business hours. See addresses below for a dealer nearest you. (Vic) Pty Ltd ACN 005 872 159 (Jetmaster).
- Additional service fees may apply if you are seeking warranty service from a dealer other than the dealer from whom you originally purchased the product.
- Check with Jetmaster in advance for any costs to you when arranging a warranty call. Travel and shipping charges for parts are not covered by this manufacturers' warranty.
- HHT and Jetmaster will assess your claim. HHT or Jetmaster may need to inspect the product as part of the assessment of your claim. If the product requires inspection, HHT or Jetmaster will discuss with you the best way for this to occur.
- To make a claim under this manufacturer's warranty, you must be able to prove when you purchased the product. The easiest way to do this is through your original proof of purchase, for example your invoice or receipt. However, if you do not have your original proof of purchase HHT or Jetmaster may accept other evidence of the date of purchase.

Local Distributors:

Melbourne	Jetmaster	44 Swan Street	Richmond 3121	(03) 9429-5573
Perth	Fireplace Corner	277 Lord Street	East Perth 6000	(08) 9228-2600
Sydney	Jetmaster	10 Martin Avenue	Arncliffe 2205	(02) 9597-7222

C. Quick Start Guide

Note: These are generic drawings and may not represent your specific model.

ITEMS NEEDED FOR FIRST FIRE: 10 Pieces of Newspaper, 10-20 Pieces of Dry Kindling and a Few Pieces of Dry Split Wood.

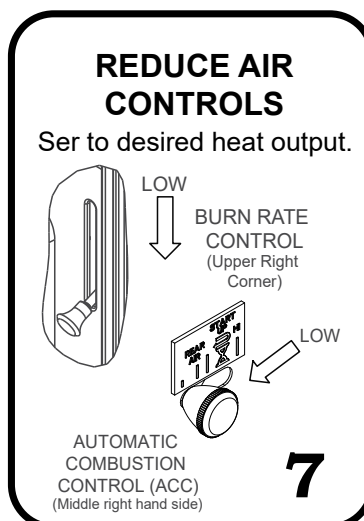
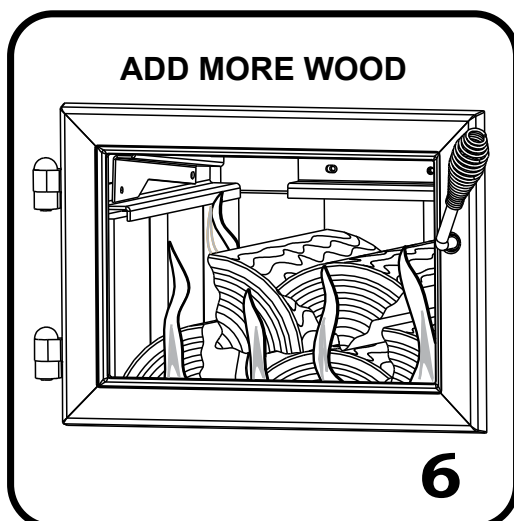
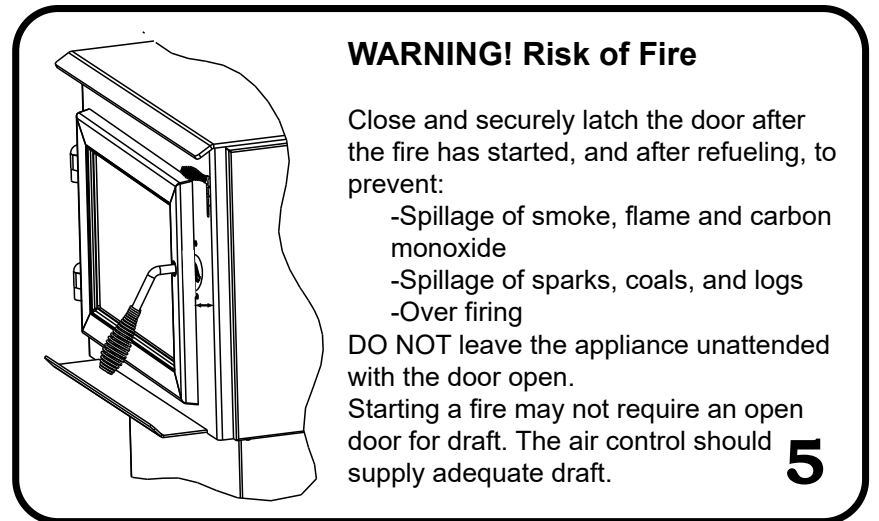
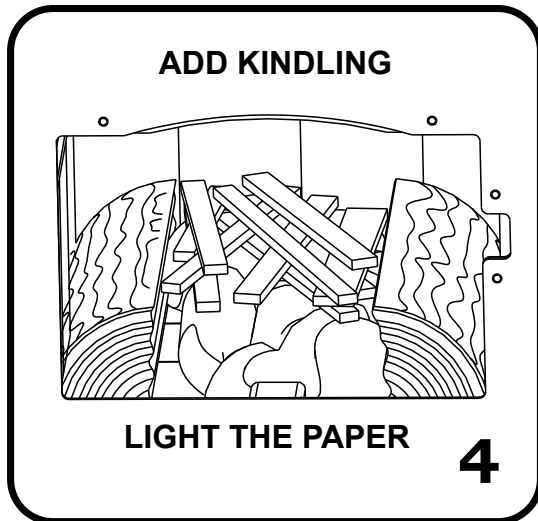
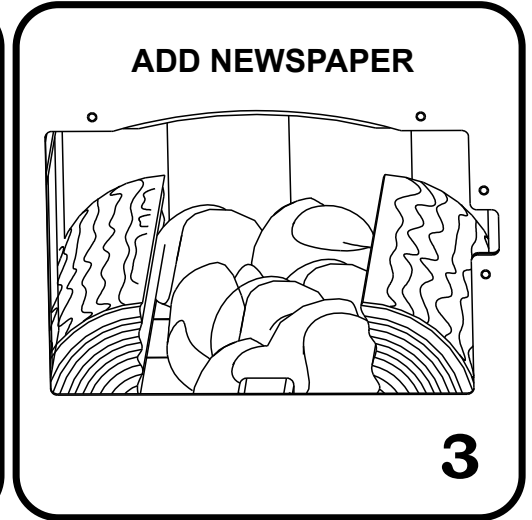
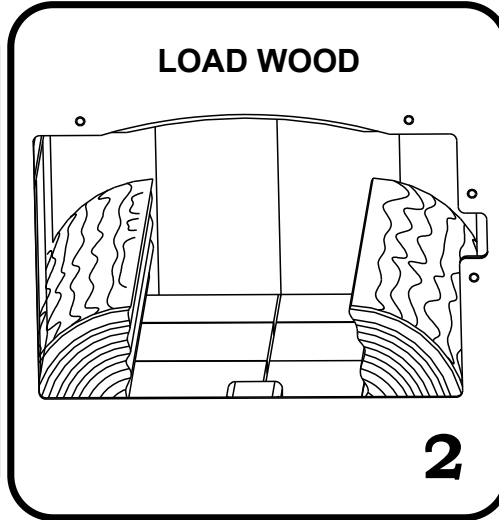
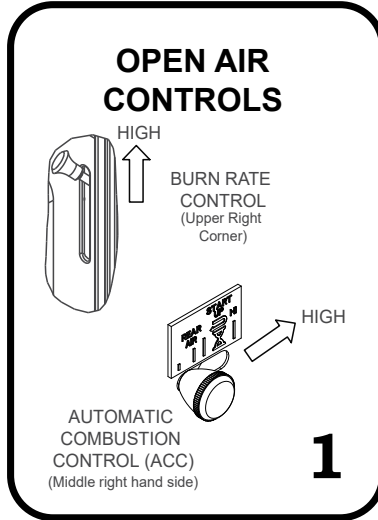

The appliance is ready for normal operation.

1 Listing and Code Approvals

A. Appliance Certification

Model:	2100 Millennium AU Wood Appliance
Laboratory:	HRL Technology
Report No:	HCMG/12/014A
Type:	Hardwood only at 25% dry basis
Standard:	AS/NZS4013 for Hardwood

B. BTU & Efficiency Specifications

Overall Average Efficiency Burning Hardwood (AS/NZS 4012)	81%
Average Particulate Emission Factor Burning Hardwood (AS/NZS 4013)	2.0 g/kg
Maximum Average Heat Output Burning Hardwood	7.2kW
Wetback	Wetbacks are NOT an approved option and must be fitted.
Vent Size:	6 inches
Firebox Size:	1.48 cubic feet
Recommended Wood Length:	16 inches
Fuel Orientation:	Front-to-Back
Approved Fuel	Hardwood only with a Moisture content less than 25% (dry basis)

NOTE: Hearth & Home Technologies, manufacturer of this appliance, reserves the right to alter its products, their specifications and/or price without notice.

The Quadra-Fire 2100 Millennium Australian Wood Appliance is Hardwood Certified. Hardwood Particulate Emissions equaling 2.0 g/kg with a Space Heating Efficiency of 81%.

This wood appliance needs periodic inspection and repair for proper operation. It is against federal regulations to operate this wood appliance in a manner inconsistent with operating instructions in this manual.

C. Glass Specifications

This appliance is equipped with 5mm ceramic glass. Replace glass only with 5mm ceramic glass. Please contact your dealer for replacement glass.



WARNING



Fire Risk.

Hearth & Home Technologies disclaims any responsibility for, and the warranty will be voided by, the following actions:

- Installation and use of any damaged appliance.
- Modification of the appliance.
- Installation other than as instructed by Hearth & Home Technologies.
- Installation and/or use of any component part not approved by Hearth & Home Technologies.
- Operating appliance without fully assembling all components.
- Operating appliance without legs attached (if supplied with appliance).
- Do NOT Over fire - If appliance or chimney connector glows, you are over firing.



Any such action that may cause a fire hazard.

Improper installation, adjustment, alteration, service or maintenance can cause injury or property damage.

For assistance or additional information, consult a qualified installer, service agency or your dealer.

2 Operating Instructions

A. Over-Firing Your Appliance

 WARNING	
	Fire Risk Do not over-fire. Over-firing may ignite creosote or will damage the appliance and chimney.
	To prevent over-firing your appliance, DO NOT: <ul style="list-style-type: none">• Use flammable liquids• Overload with wood• Burn trash or large amounts of scrap lumber• Permit too much air to the fire

1. Symptoms of Over-Firing

Symptoms of over-firing may include one or more of the following:

- Chimney connector or appliance glowing
- Roaring, rumbling noises
- Loud cracking or banging sounds
- Metal warping
- Chimney fire

2. What To Do if Your Appliance is Over-Firing

- Immediately close the door and air controls to reduce air supply to the fire.
- If you suspect a chimney fire, call the fire department and evacuate your house.
- Contact your local chimney professional and have your appliance and appliance pipe inspected for any damage.
- Do not use your appliance until the chimney professional informs you it is safe to do so.

Hearth & Home Technologies WILL NOT warranty appliances that exhibit evidence of over-firing. Evidence of over-firing includes, but is not limited to:

- Warped air tube
- Deteriorated refractory brick retainers
- Deteriorated baffle and other interior components

B. Wood Selection & Storage

Burn only dry seasoned wood. Store wood under cover, out of the rain and snow. Dry and well-seasoned wood will not only minimize the chance of creosote formation, but will give you the most efficient fire. Even dry wood contains at least 15% moisture by weight, and should be burned hot enough to keep the chimney hot for as long as it takes to dry the wood out - about one hour. It is a waste of energy to burn unseasoned wood of any kind.

Dead wood lying on the forest floor should be considered wet, and requires full seasoning time. Standing dead wood can be considered to be about 2/3 seasoned. To tell if wood is dry enough to burn, check the ends of the logs. If there are cracks radiating in all directions from the center, it is dry. If your wood sizzles in the fire, even though the surface is dry, it may not be fully cured.

Splitting wood before it is stored reduces drying time. Wood should be stacked so that both ends of each piece are exposed to air, since more drying occurs through the cut ends than the sides. This is true even with wood that has been split. Store wood under cover, such as in a shed, or covered with a tarp, plastic, tar paper, sheets of scrap plywood, etc., as uncovered wood can absorb water from rain or snow, delaying the seasoning process.

C. Burning Process

In recent years there has been an increasing concern about air quality. Much of the blame for poor air quality has been placed on the burning of wood for home heating. In order to improve the situation, we at Quadra-Fire have developed cleaner-burning wood appliances that surpass the requirements for emissions established by our governing agencies. These wood appliances, like any other appliances, must be properly operated in order to insure that they perform the way they are designed to perform. Improper operation can turn most any wood appliance into a smoldering environmental hazard.

1. Kindling or First Stage - It helps to know a little about the actual process of burning in order to understand what goes on inside a appliance. The first stage of burning is called the kindling stage. In this stage, the wood is heated to a temperature high enough to evaporate the moisture which is present in all wood. The wood will reach the boiling point of water (212°F) and will not get any hotter until the water is evaporated. This process takes heat from the coals and tends to cool the appliance.

Fire requires three things to burn - fuel, air and heat. So, if heat is robbed from the appliance during the drying stage, the new load of wood has reduced the chances for a good clean burn. For this reason, it is always best to burn dry, seasoned firewood. When the wood isn't dry, you must open the air controls and burn at a high burn setting for a longer time to start it burning. The heat generated from the fire should be warming your home and establishing the flue draft, not evaporating the moisture out of wet, unseasoned wood, resulting in wasted heat.

2. Second Stage - The next stage of burning, the secondary stage, is the period when the wood gives off flammable gases which burn above the fuel with bright flames. During this stage of burning it is very important that the flames be maintained and not allowed to go out. This will ensure the cleanest possible fire. If the flames tend to go out, it is set too low for your burning conditions. The air control located at the upper right hand corner is used to adjust for burn rates. This is called the Burn Rate Air Control (Figure 9.1 on page 9).

3. Final Stage

The final stage of burning is the charcoal stage. This occurs when the flammable gases have been mostly burned and only charcoal remains. This is a naturally clean portion of the burn. The coals burn with hot blue flames.

It is very important to reload your appliance while enough lively hot coals remain in order to provide the amount of heat needed to dry and rekindle the next load of wood. It is best to open the Burn Rate Air and Start-Up Air Controls **before reloading**. This livens up the coal bed and reduces excessive emissions (opacity/smoke). Open door slowly so that ash or smoke does not exit appliance through opening. You should also break up any large chunks and distribute the coals so that the new wood is laid on hot coals.

Air quality is important to all of us, and if we choose to use wood to heat our homes we should do so responsibly. To do this we need to learn to burn our appliances in the cleanest way possible. Doing this will allow us to continue using our wood appliances for many years to come.

D. Air Controls

Users will need to find their preferred setting between high and low based on desired heat output, installation configuration, and fuel type.

1. Burn Rate Air Control - This air supply enters at the upper front of the firebox, near the top of the glass door. This preheated air supplies the necessary fresh oxygen to mix with the unburned gases, helping to create second, third and fourth combustions. This air is regulated by the Burn Rate Air Control. When the control is moved all the way up it is on the High setting and when moved all the way down it is on the Low setting (**Figure 9.1**).

2. Automatic Combustion Control System (ACC) - To engage the Automatic Combustion Control (ACC) timer system push the lever towards the back of the appliance to the "HI" position, then pull forwards towards the front of the appliance until the knob stops. The timer will slowly close in about 25 minutes. Use this feature when reloading fuel or if you want more air supplied to the fire (**Figure 9.3**).

E. Using Burn Rate Air Control & ACC System

1. Start up and Reloading Fuel - Open both Burn Rate Air Control and ACC systems fully. To do this with the Burn Rate Air Controls push spring handle up to high. For the ACC timer system push knob towards back of appliance until the knob is located under the high position (**Figure 9.1**).

2. Maximize Heat with The ACC System - To maximize heat output with the ACC timer System or also known as high burn push the ACC Air Control lever towards the back of the appliance and leave. This combined with having the main burn rate control lever pushed up will deliver the most amount of air needed to achieve the highest amount of heat output (**Figure 9.1**).

3. Manual Timer Over-Ride - If you need to shut the ACC system off before it goes through the cycle of shutting itself off; 25 minutes, reach towards the back of the appliance on the right side and pull the lever towards the front of the appliance (**Figure 9.2**).

**CAUTION**

**Injury Risk.**

- Gloves recommended

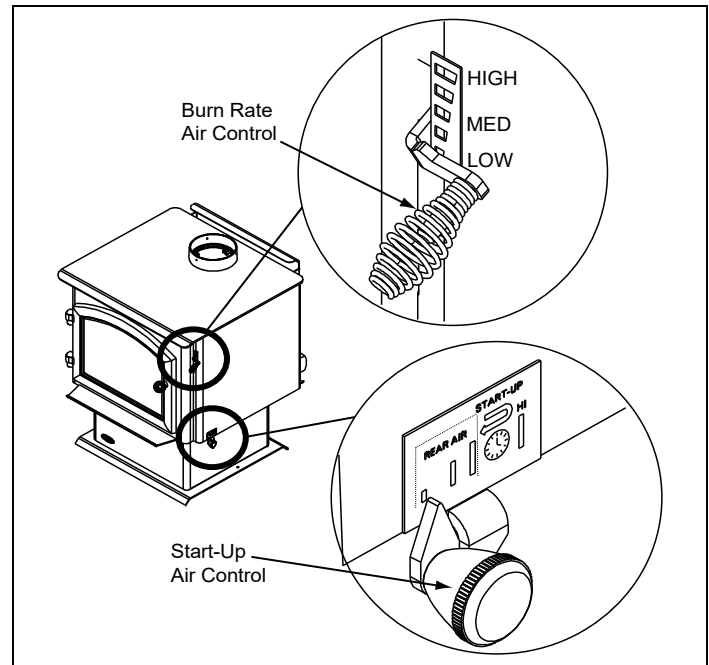

Figure 9.1

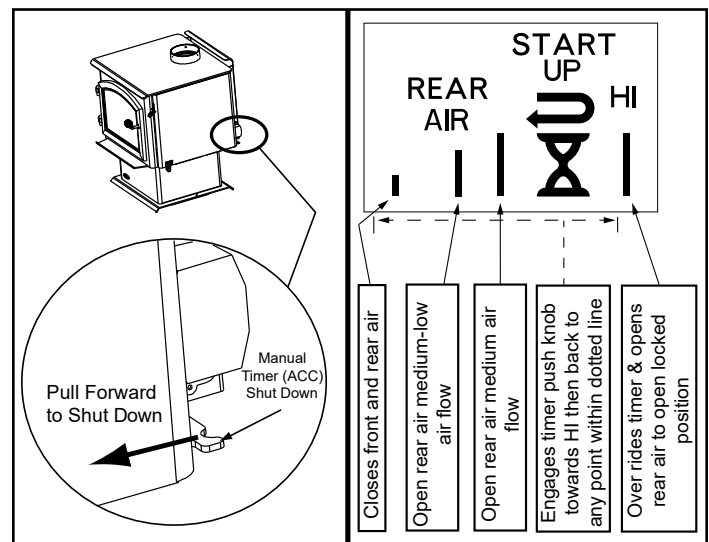

Figure 9.2

Figure 9.3

F. Burn Rates and Operating Efficiency

For maximum operating efficiency

This wood appliance has a manufacturer-set minimum low burn rate that must not be altered. It is against federal regulations to alter this setting or otherwise operate this wood appliance in a manner inconsistent with operating instructions in this manual.

- Burn dry, well-seasoned wood.

Burn Rates

1. Low burn setting:

- Burn Rate Air Control spring handle up to high position for 5 minutes.
- Then activate the ACC timer system by pushing the knob all the back toward the appliance to “HI” then pull forwards towards the front of the appliance until the knob stops (Figure 9.1 on page 9).
- At that point close the Burn Rate Air Control by moving the spring handle to the low setting.

2. Medium low burn setting:

- Burn Rate Air Control spring handle up to high position for 5 minutes.
- Then activate the ACC timer system by pushing the knob all the back toward the appliance to “HI” then pull forwards towards the front of the appliance until the knob stops.
- At that point move the Burn Rate Air Control spring handle to 1/8”-1/2” from the low setting.

3. Medium high burn setting:

- Burn Rate Air Control spring handle up to high position.
- Then activate the ACC timer system by pushing the knob all the back toward the appliance to “HI” then pull forwards towards the front of the appliance until the knob stops.
- At that point move the Burn Rate Air Control spring handle to 1/2” – high.

4. High burn setting:

- Burn Rate Air Control spring handle up to high position
- Also activate ACC timer system knob pushed back to the “HI” position.

NOTE: If using the optional blower use burn settings 1-3 burn settings the blower shall be off for the first 30 minutes and then be operated in the high position at 30 minutes. For high burn setting, blower may continue to be on full after the loading of the fuel.

NOTE: The above information is provided as a guideline only. Altitude and other circumstances may require control adjustments to achieve the desired burn rates.

NOTE: Operate appliance on High Burn 45 minutes a day to help keep flue/chimney clean.



WARNING



Risk of Fire.

When set on High Burn Rate and over-riding the Automatic Combustion Control system an over fire situation can occur and may result in a chimney fire.

Over firing will void the appliance warranty.

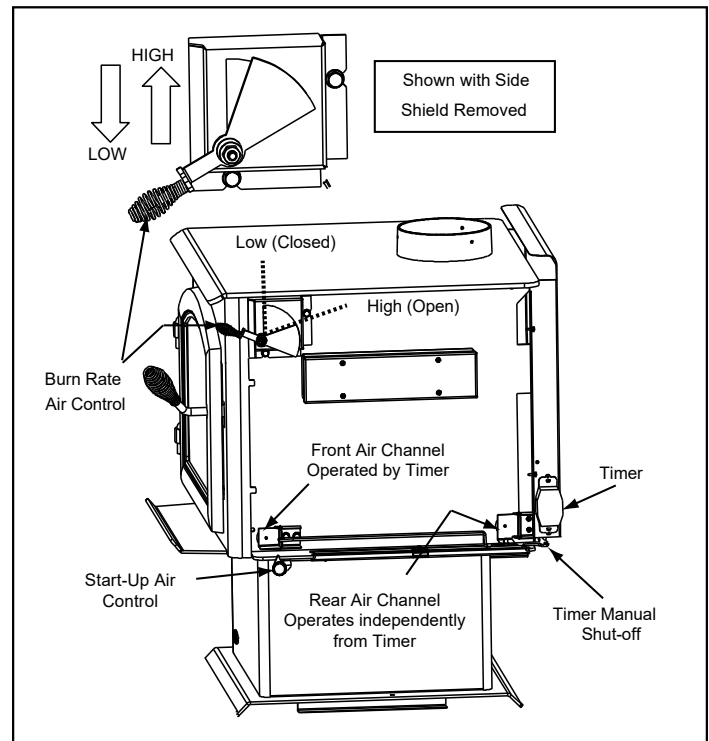

Figure 10.1

After activating the timer (ACC), if the control is placed within the rear air section on the label it will allow rear air to enter the firebox. This will not interfere with the timer gradually closing the front air channel in 25 minutes. If control is set on “HI” it over-rides the timer (ACC).

G. Building A Fire

Before lighting your first fire in the appliance:

NOTE: The special high temperature paint that your appliance is finished with will cure as your appliance heats. You will notice an odor and perhaps see some vapor rise from the appliance surface; this is normal. We recommend that you open a window until the odor dissipates and paint is cured.

1. Confirm the baffle is correctly positioned. It should be even with the front tube and resting on all tubes (**Figure 11.1 and 11.2**).

2. Remove all labels from glass and inside of appliance.

There are many ways to build a fire. The basic principle is to light easily-ignitable tinder or paper, which ignites the fast burning kindling, which in turn ignites the slow-burning firewood. Here is one method that works well:

3. Open the Burn Rate Air and ACC Controls fully (Refer to page 6 Start-Up Guide).
4. Place several wads of crushed paper on the firebox floor. Heating the flue with slightly crumpled newspaper before adding kindling keeps smoke to a minimum.
5. Lay small dry sticks of kindling on top of the paper.
6. Make sure that no matches or other combustibles are in the immediate area of the appliance. Be sure the room is adequately ventilated and the flue unobstructed.
7. Light the paper in the appliance. **NEVER** light or rekindle fire with kerosene, gasoline, or charcoal lighter fluid; the results can be fatal.
8. Once the kindling is burning quickly, add several full-length logs 3 inches (76mm) or 4 inches (102mm) in diameter. Be careful not to smother the fire. Stack the pieces of wood carefully; near enough to keep each other hot, but far enough away from each other to allow adequate air flow between them.
9. Set the Burn Rate Air Control and activate the ACC timer system.
10. When ready to reload, It is best to fully open both the Burn Rate Air and Start-up Air Controls **before reloading**. This livens up the coal bed and reduces excessive emissions (opacity/smoke). Open door slowly so that ash or smoke does not exit appliance through opening. Large logs burn slowly, holding a fire longer. Small logs burn fast and hot, giving quick heat.
11. As long as there are hot coals, repeating steps 6 through 8 will maintain a continuous fire.

NOTE:

- Build fire on brick firebox floor.
- Do NOT use grates, andirons or other methods to support fuel. It will adversely affect emissions.



WARNING

Fire Risk

Do NOT store wood:

- Closer than required clearances to combustibles to appliance
- Within space required for loading or ash removal.

Do NOT operate appliance:

- With appliance door open.
- With ash removal system door open.



Baffle Board even with front tube & resting on all tubes

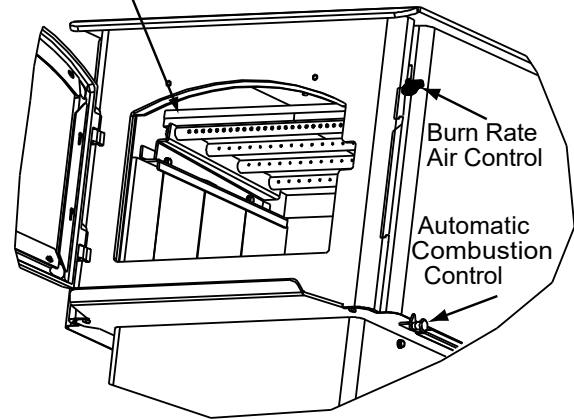

Ceramic Blanket on Top

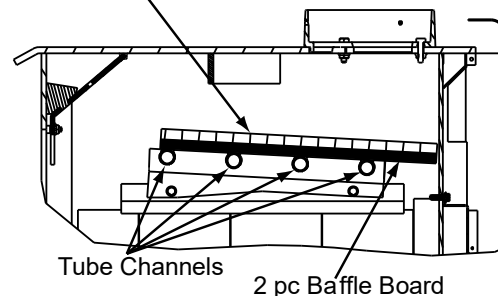

Figure 11.1



WARNING

Fire Risk

- Do NOT burn wet or green wood.
 - Store wood in dry location.
 - Stack wood so both ends are exposed to air.
- Wet, unseasoned wood can cause accumulation of creosote.



H. Correct Baffle & Blanket Placement



WARNING



Fire Risk

Firebox damage due to improper baffle placement is not covered by warranty. Operate the wood burning appliance with the baffle in the correct position only.

Not doing so could result in:

- Reduced efficiency
- Overheating the chimney
- Overheating the rear of the firebox
- Poor performance

Ensure correct baffle placement and replace baffle components if damaged or missing.



CAUTION

The baffle boards are **FRAGILE**. Use extreme caution when loading firewood to prevent:

- Cracking, breaking or damaging the baffle boards
- DO NOT** operate the appliance without baffle boards

CORRECT POSITION

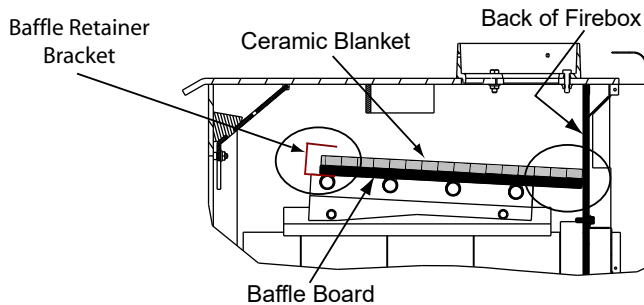

Ceramic Blanket and Baffle Board **MUST** be in contact with the back of the firebox and even with each other in the front.

Figure 12.1

INCORRECT POSITIONS

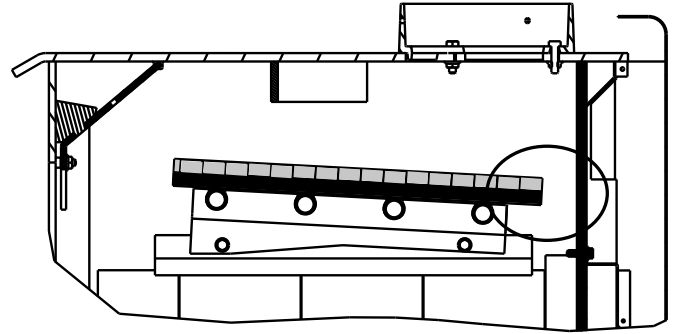

Ceramic Blanket and Baffle Board are **NOT** in contact with the back of the firebox.

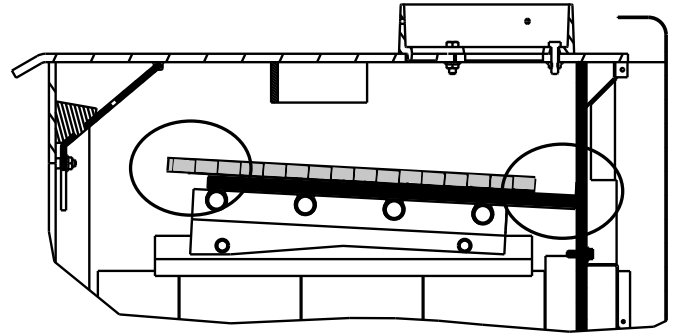

Ceramic Blanket is **NOT** in contact with the back of the firebox and **NOT** even with the Baffle Board in the front.

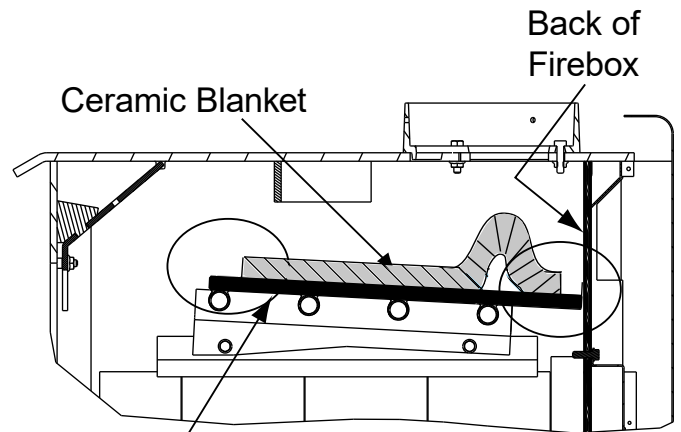

Ceramic Blanket is bunched up at the back of the firebox and **NOT** even with the Baffle Board in the front.

I. Opacity (Smoke)

This is the measure of how cleanly your appliance is burning. Opacity is measured in percent; 100% opacity is when an object is totally obscured by the smoke column from a chimney, and 0% opacity means that no smoke column can be seen. As you become familiar with your appliance, you should periodically check the opacity. This will allow you to know how to burn as nearly smoke-free as possible (goal of 0% opacity).



WARNING



Fire Risk.

- DO NOT BURN GARBAGE OR FLAMMABLE FLUIDS SUCH AS GASOLINE, NAPHTHA OR ENGINE OIL.

- Do NOT burn treated wood or wood with salt (driftwood).
- May generate carbon monoxide if burn material other than wood.

May result in illness or possible death.



WARNING



Fire Risk.

Keep combustible materials, gasoline and other flammable vapors and liquids clear of appliance.

- Do NOT store flammable materials in the appliance's vicinity.
- DO NOT USE GASOLINE, LANTERN FUEL, KEROSENE, CHARCOAL LIGHTER FLUID OR SIMILAR LIQUIDS TO START OR "FRESHEN UP" A FIRE IN THIS Appliance.
- Keep all such liquids well away from the appliance while it is in use.
- Combustible materials may ignite.



CAUTION

When burning your first fire, you will experience smoke and odor from the appliance resulting from the curing of paint and burning off of any oils remaining from manufacturing; suggest:

- Open windows during initial burn to dissipate smoke and odors!
- Odors may be irritating to sensitive individuals.
- Smoke detectors may activate.

J. Clear Space

- Do NOT place combustible objects within 1.2m of the front of appliance (See **Figure 13.1**).
- Mantel - avoid placing candles and other heat-sensitive objects on mantel or hearth. Heat may damage these objects.



WARNING

Do NOT place combustible objects in front of the appliance. High temperatures may ignite clothing, furniture or draperies.

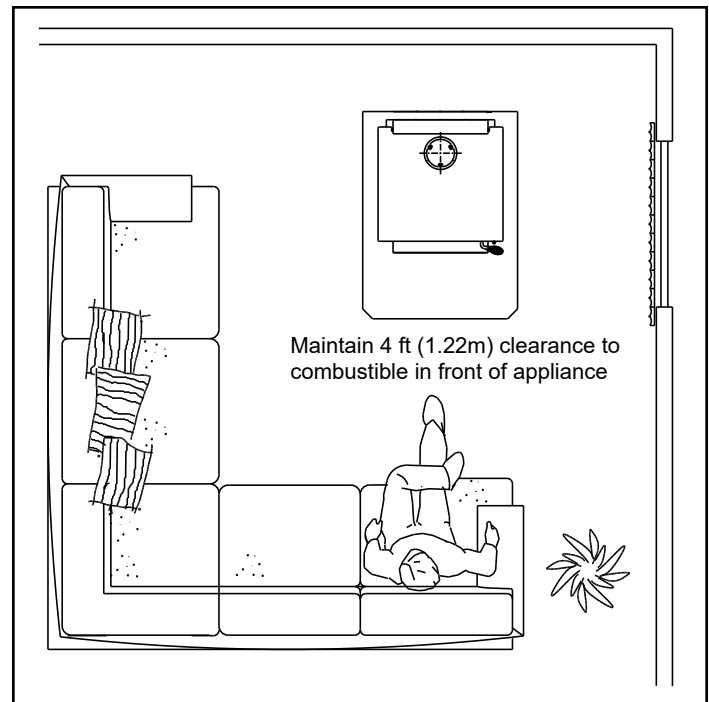



Figure 13.1

K. Negative Pressure

 WARNING	
	<p>Asphyxiation Risk.</p> <ul style="list-style-type: none"> Negative pressure can cause spillage of combustion fumes, soot and carbon monoxide. Appliance needs to draft properly for safety.

Negative pressure results from the imbalance of air available for the appliance to operate properly. It can be strongest in lower levels of the house.

Causes include:



- Exhaust fans (kitchen, bath, etc.)
- Range hoods
- Combustion air requirements for furnaces, water appliances and other combustion appliances
- Clothes dryers
- Location of return-air vents to furnace or air conditioning
- Imbalances of the HVAC air handling system
- Upper level air leaks such as:
 - Recessed lighting
 - Attic hatch
 - Duct leaks

L. Frequently Asked Questions

ISSUES	SOLUTIONS
Odor from appliance	When first operated, this appliance may release an odor for the first several hours. This is caused by the curing of the paint and the burning off of any oils remaining from manufacturing.
Metallic noise	Noise is caused by metal expanding and contracting as it heats up and cools down, similar to the sound produced by a furnace or heating duct. This noise does not affect the operation or longevity of the appliance.
Whirring sound	If the optional blower has been installed, the blower produces a whirring sound which increases in volume as the speed is increased.



CONTACT YOUR DEALER for additional information regarding operation and troubleshooting.

Visit www.quadrafire.com to find a dealer.

 WARNING	
	<p>Fire Risk.</p> <ul style="list-style-type: none"> DONOTBURN GARBAGE OR FLAMMABLE FLUIDS SUCH AS GASOLINE, NAPHTHA OR ENGINE OIL. Do NOT burn treated wood or wood with salt (driftwood). <p>• May generate carbon monoxide if burn material other than wood. May result in illness or possible death.</p>

To minimize the effects of negative air pressure:

- Install the outside air kit with the intake facing prevailing winds during the heating season
- Ensure adequate outdoor air for all combustion appliances and exhaust equipment
- Ensure furnace and air conditioning return vents are not located in the immediate vicinity of the appliance
- Avoid installing the appliance near doors, walkways or small isolated spaces
- Recessed lighting should be a “sealed can” design
- Attic hatches weather stripped or sealed
- Attic mounted duct work and air handler joints and seams taped or sealed

 WARNING	
	<p>Fire Risk.</p> <p>Keep combustible materials, gasoline and other flammable vapors and liquids clear of appliance.</p> <ul style="list-style-type: none"> Do NOT store flammable materials in the appliance’s vicinity. DO NOT USE GASOLINE, LANTERN FUEL, KEROSENE, CHARCOAL LIGHTER FLUID OR SIMILAR LIQUIDS TO START OR “FRESHEN UP” A FIRE IN THIS APPLIANCE. Keep all such liquids well away from the appliance while it is in use. Combustible materials may ignite.

B. General Maintenance

1. Creosote (Chimney) Cleaning

- **Frequency:** Every 2 months during heating season or as recommended by a certified chimney sweep; more frequently if chimney exceeds or is under 14-16 ft. (measured from bottom of appliance)
- **By:** Certified Chimney Sweep

Remove all ash from the firebox and extinguish all hot embers before disposal. Allow the appliance to cool completely. Disconnect flue pipe or remove baffle and ceramic blanket from appliance before cleaning chimney. Otherwise residue can pile up on top of the baffle and ceramic blanket and the appliance will not work properly. (See Baffle Removal on page 20). Close the door tightly. The creosote or soot should be removed with a brush specifically designed for the type of chimney in use. Clean out fallen ashes from the firebox.



It is also recommended that before each heating season the entire system be professionally inspected, cleaned and repaired if necessary.



Inspection: Inspect the system at the appliance connection and at the chimney top. Cooler surfaces tend to build creosote deposits quicker, so it is important to check the chimney from the top as well as from the bottom.

Formation and Need For Removal: When wood is burned slowly, it produces tar and other organic vapors which combine with expelled moisture to form creosote.

The creosote vapors condense in the relatively cool chimney flue of a newly-started or a slow-burning fire. As a result, creosote residue accumulates on the flue lining. When ignited, this creosote creates an extremely hot fire which may damage the chimney or even destroy the house.

The chimney connector and chimney should be inspected once every 2 months during the heating season to determine if a creosote or soot buildup has occurred. If creosote or soot has accumulated, it should be removed to reduce the risk of a chimney fire.



 WARNING	
	Fire Risk. Prevent creosote buildup.
	<ul style="list-style-type: none">• Inspect chimney connector and chimney once every two months during heating season.• Remove creosote to reduce risk of chimney fire.• Ignited creosote is extremely HOT.

 WARNING	
	Fire Risk.
	<ul style="list-style-type: none">• Do not use chimney cleaners or flame colorants in your appliance. Will corrode chimney pipe.

2. Disposal of Ashes

- **Frequency:** When ash is within 44mm of firebox lip
- **By:** Homeowner

Ashes should be placed in a metal container with a tight fitting lid. The closed container of ashes should be placed on a non-combustible floor or on the ground, well away from all combustible materials, pending final disposal. If the ashes are disposed of by burial in soil or otherwise locally dispersed, they should be retained in the closed container until all cinders have thoroughly cooled.

 WARNING	
	Fire Risk. Disposal of Ashes
	<ul style="list-style-type: none">• Ashes should be placed in metal container with tight fitting lid.• Do not place metal container on combustible surface.• Ashes should be retained in closed container until all cinders have thoroughly cooled.

3. Cleaning Plated Surfaces

- **Frequency:** Prior to first burn and then as desired
- **By:** Homeowner

Clean all the fingerprints and oils from plated surfaces BEFORE firing the appliance for the first time. If not cleaned properly before lighting your first fire, the oils can cause permanent markings on the plating.

After the plating is cured, the oils will not affect the finish and little maintenance is required. Wipe clean as needed.

 CAUTION	
<ul style="list-style-type: none">• Do not use polishes with abrasives. It will scratch plated surfaces.	

4. Glass Cleaning

- **Frequency:** As desired
- **By:** Homeowner

Clean glass with a non-abrasive glass cleaner. Abrasive cleaners may scratch and cause glass to crack. If the deposits on the glass are not very heavy, normal glass cleaners work well. Heavier deposits may be removed by using a damp cloth dipped in wood ashes or by using a commercially available oven cleaner.

After using an oven cleaner, it is advisable to remove any residue with a glass cleaner or soap and water. Oven cleaner left on during the next firing can permanently stain the glass and damage the finish on metal surfaces.

A portion of the combustion air entering the firebox is deflected down over the inside of the door glass. This air flow “washes” the glass, helping to keep smoke from adhering to its surface.

When operated at a low burn rate, less air will be flowing over the glass and the smokey, relatively cool condition of a low fire will cause the glass to become coated.

Operating the appliance with the Burn Rate Air Control and Start-Up Air Control all the way open for 30-45 minutes should remove the built up coating.



CAUTION

- Do not use polishes with abrasives. It will scratch plated surfaces.

4 Troubleshooting Guide

With proper installation, operation, and maintenance your wood appliance will provide years of trouble-free service. If you do experience a problem, this troubleshooting guide will assist you or a qualified service person in the diagnosis of a problem and the corrective action to be taken.

Start Fire Problems	Possible Cause	Solution
Can not get fire started Excessive smoke or spillage Burns too slowly Not enough heat output	Not enough kindling/paper or no kindling/paper	Use dry kindling, more paper. Arrange kindling & wood for air movement.
	Not enough air for fire to ignite	Check for restricted termination cap
		Check for blockage of outside air kit (if installed).
		Check for flue blockage.
		Warm flue before starting fire (refer to Building a Fire Section).
		Check for adequate vent height (refer to Chimney Height Section).
	Open window below the appliance towards the wind.	
	Wood condition is too wet, too large	Use dry, seasoned wood (refer to Seasoned Wood Section).
	Bed of coals not established before adding wood	Start with paper & kindling to establish bed of coals (refer to Building a Fire Section).
Flue blockage such as birds' nests or leaves in termination cap	Have chimney inspected for creosote and cleaned by a certified chimney sweep.	
Down draft or negative pressure Competition with exhaust devices	Do not use exhaust fans during start-up (refer to Negative Pressure Section).	
	Open window below the appliance towards the wind.	
Fire burns too fast	Extremely dry or soft wood	Mix in hardwood.
		Mix in less seasoned wood after fire is established (refer to Wood Fuel Section).
	Over drafting	Check for correct vent height; too much vertical height creates over drafting.
		Check location of vent termination (refer to Chimney Termination Requirement Section).

5 Service Parts Replacement

A. Glass Replacement - Door Assembly

(Replace with 5mm ceramic glass only)

1. Ensure that the fire is out and the appliance is cool to the touch.
2. Protect a table or counter top with padding or towels. Protect your hands and wear gloves to prevent injury.
3. Remove the door with the broken glass by lifting the door up and off of the hinges.
4. Lay door face down on a table or counter making sure the handle hangs over the edge so the door lays flat, on a soft surface.
5. Remove the screws from each glass retainer and remove the glass. (If screws are difficult to remove, soak with penetrating oil first).
6. Center the glass with edges evenly overlapping the opening in the door, (i.e. same space top and bottom, left and right sides).
7. Replace the glass retainers. Be careful not to cross thread the screws.
8. Tighten each retainer just a few turns until each is secured. Check again for centering of glass in door frame. Continue to tighten each retainer alternately, a few turns at a time, until the glass is secure. **DO NOT OVER TIGHTEN** - can cause glass to break.
9. Replace the door on the appliance.

Quadra-Fire appliances are equipped with ceramic super heat-resistant glass, which can only be broken by impact or misuse.

**WARNING**



Injury Risk.

- Use only glass specified in manual.
- **DO NOT REPLACE** with any other material.

**CAUTION**

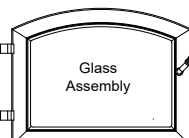

Handle glass assembly with care.
When cleaning glass:

- Avoid striking, scratching or slamming glass.
- Do NOT clean glass when hot.
- Do NOT use abrasive cleaners.
- Use a hard water deposit glass cleaner on white film.
- Use commercial oven cleaner on heavier deposits.
- Remove all residue of oven cleaner or will permanently stain glass on next firing. Refer to maintenance instructions

B. Firebrick Replacement

Replace the firebrick if they become crumbly and/or if there is a 6.35mm gap between the bricks.

Inspect the firebrick after each ash removal.

The firebox is lined with high quality firebrick, which has exceptional insulating properties. There is no need to use a grate; simply build a fire on the firebox floor. Do not operate appliance without firebrick.

1. After the coals have completely cooled, remove all old brick and ash from appliance and vacuum firebox.
2. Remove new brick set from box and lay out to diagram shown.
3. Lay bottom bricks in appliance.
4. Install rear bricks on the top of the bottom bricks. Slide top of bricks under clip on back of firebox wall and push bottom of brick back.
5. Install side bricks. Slide top of brick under clips on side of firebox and push the bottom of the brick until it is flush with the side of the appliance.

C. Door Handle Assembly

1. Slide door handle through door.
2. Install additional washer(s) as shown in **Figure 19.1**
3. Install key in groove.
4. Align groove in latch cam with key; slide latch cam over shaft
5. Install locknut but do not over tighten, the handle needs to rotate smoothly.
6. Install fiber handle (**Figure 19.1**).

**CAUTION**

Do not over tighten lock nut. The door handle needs to move smoothly.

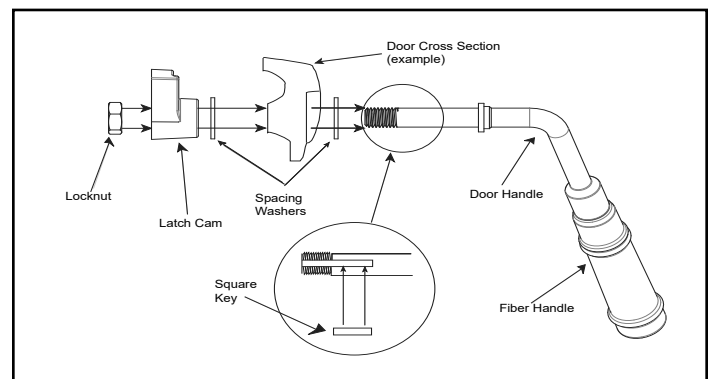

Figure 19.1

D. Baffle Removal

1. Remove all ash from the firebox, and extinguish all hot embers before disposal into a metal container.
2. The baffle board has 2 pieces. With the ceramic blanket still in place, slide one baffle piece over the top of other one and pull out top piece through the door opening and then remove bottom baffle piece (**Figure 20.1**).
3. Remove the ceramic blanket.
4. Re-install the baffle pieces one piece at a time. Be sure the baffle boards are even with the front manifold tube and is resting on all tubes (**Figure 20.3**).
5. To re-install the ceramic blanket, it is easier to fold it in half first. Place on top of baffle board, open up and flatten and smooth out the blanket. Re-check the baffle board for correct positioning (**Figure 20.2**).



Figure 20.1 - Baffle



Figure 20.2 - Ceramic Blanket

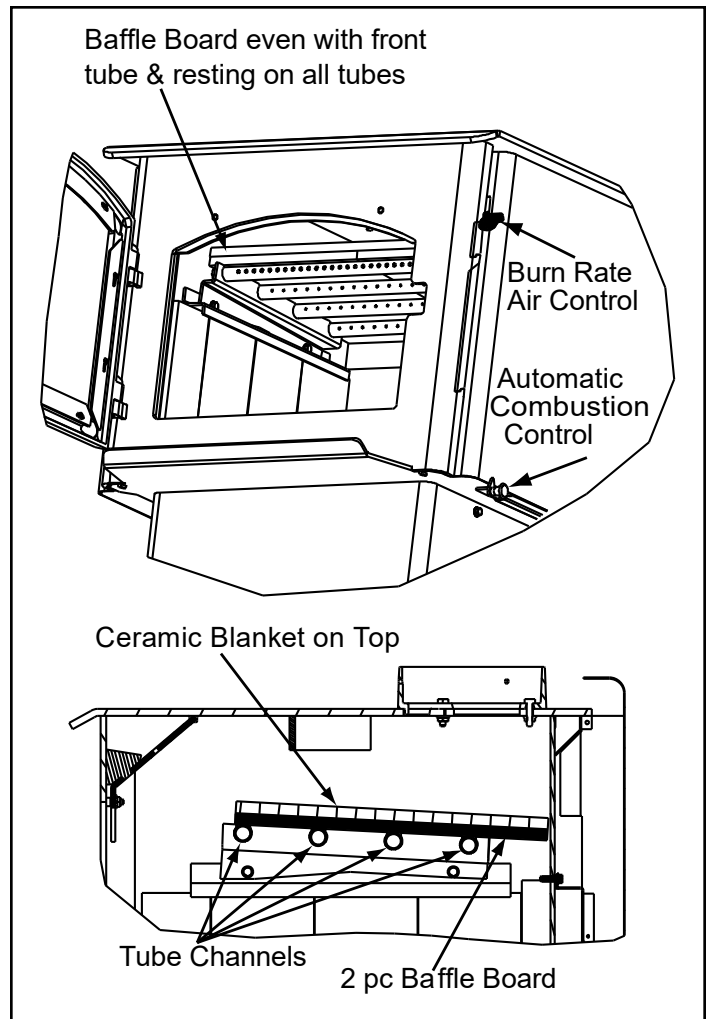

Figure 20.3

E. Tube Channel Assembly Replacement

Removing Tube Channel Assembly

1. Remove the right side shield by lifting up on side to remove.
2. Remove 4 screws from channel access cover and remove cover.
3. Locate 2 channel nuts inside of chamber and remove using a 7/16 socket wrench. Slide out tube channel assembly.

NOTE: Soak the bolts with penetrating oil for at least 15 minutes before trying to remove them.

Replacing Tube Channel Assembly

4. Slide one gasket onto each tube.
5. Slide the tube channel assembly into side of firebox and insert each tube into the corresponding hole in the tube channel rack starting with the back hole first.
6. Make sure tube channel assembly is flush against the side of the appliance and secure with channel nuts.
7. Re-install channel cover and side shield.

NOTE: Service Space

In order to replace the tube channel assembly a clearance of 483mm is required on the right side of appliance in order to remove the tubes with the appliance in place.

If space is not available, the appliance will have to be disconnected from the chimney to proceed with the tube replacement.

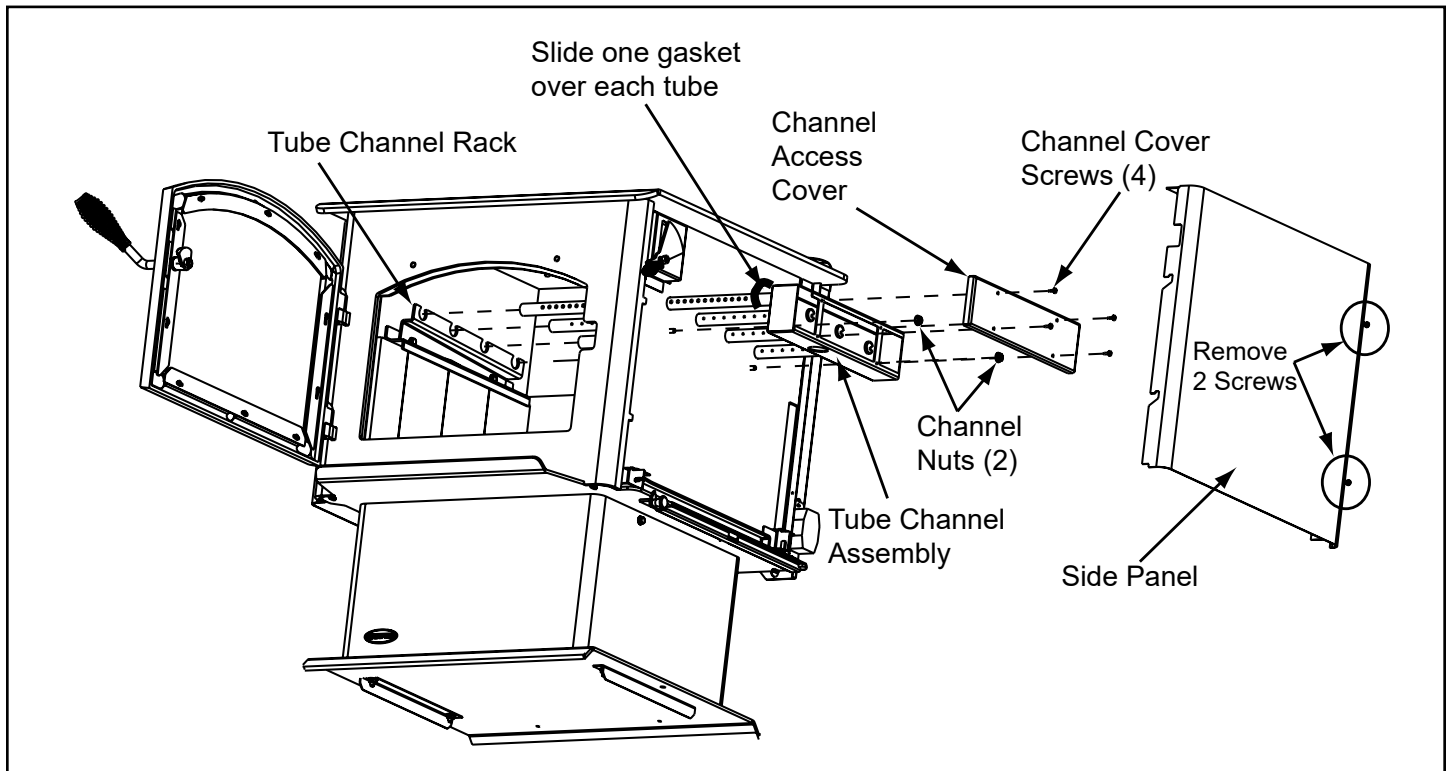

Figure 21.1

B. Service Parts

QUADRA-FIRE® Service Parts

21M-ACC-AU

2100 Millennium Wood Stove
Advanced Combustion Control (ACC)

Beginning Manufacturing Date: July 2007
Ending Manufacturing Date: Feb 2020
Reactivation Date: April 2022

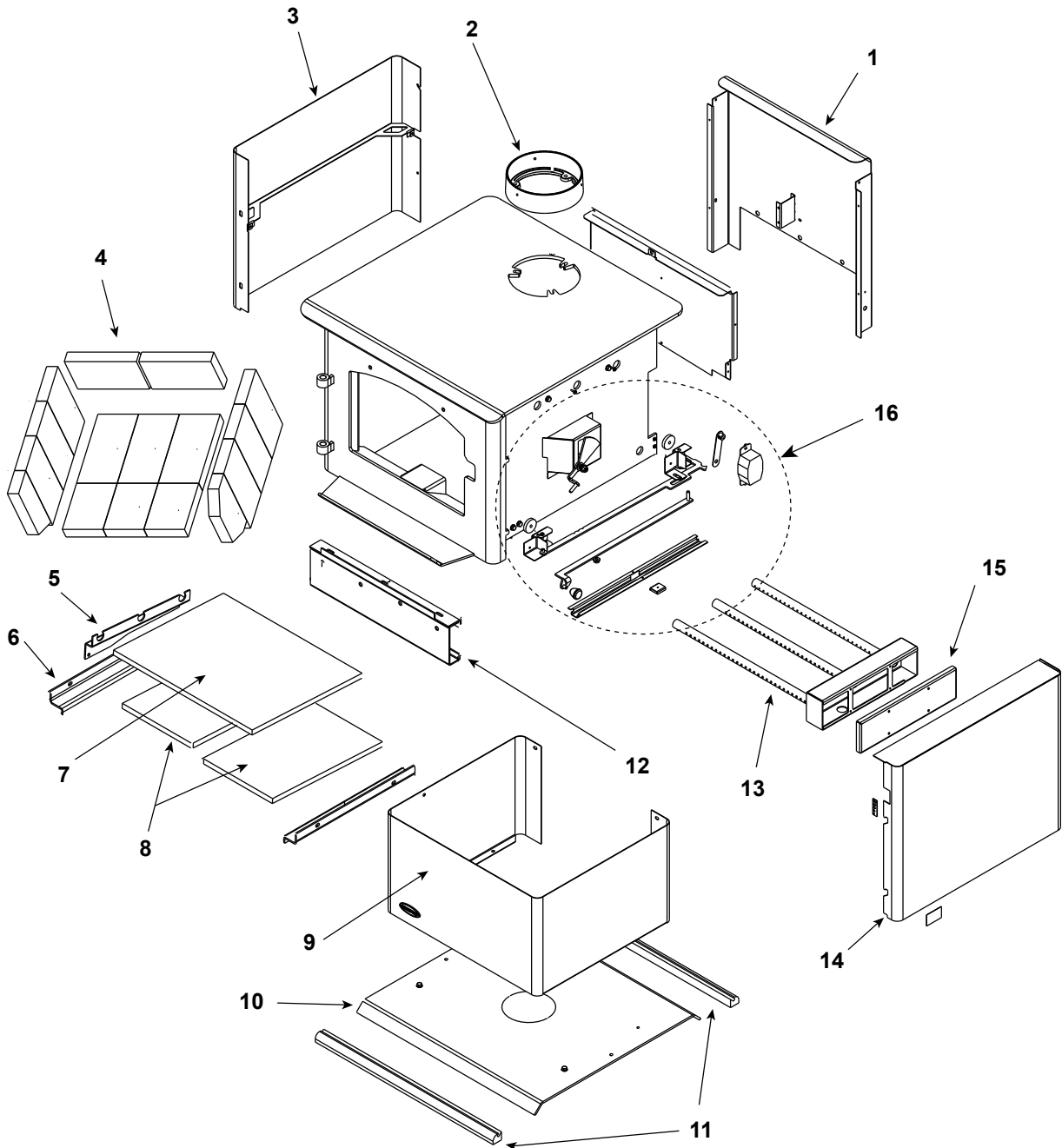

Part number list on following pages.

04/22

Beginning Manufacturing Date: July 2007

Ending Manufacturing Date: Feb 2020

Reactivation Date: April 2022

IMPORTANT: THIS IS DATED INFORMATION. When requesting service or replacement parts for your appliance please provide model number and serial number. All parts listed in this manual may be ordered from an authorized dealer.



Stocked at Depot

ITEM	DESCRIPTION	COMMENTS	PART NUMBER	
1	Convection Air Channel - Retain Original Serial Number		SRV7039-107	
2	Flue Collar		SRV7000-302	Y
3	Panel Assembly, Side, Left		SRV7039-003	

#4 Brick Assembly

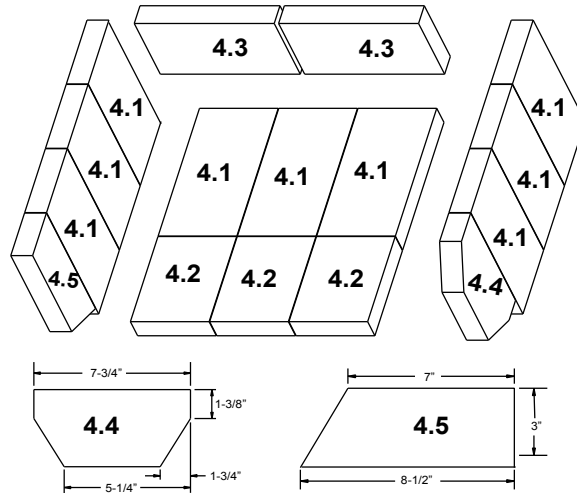

4	Brick Assembly - Complete Set		SRV7039-007	
4.1	Brick, 9 x 4-1/2 x 1-1/4"	Qty. 9 Req.		
4.2	Brick, 5 3/4 x 4-1/2 x 1-1/4"	Qty. 3 Req.		
4.3	Brick, 8 x 4-1/2 x 1-1/4"	Qty. 2 Req.		
4.4	Brick, see diagram	Qty. 1 Req.		
4.5	Brick, see diagram	Qty. 1 Req.		
	Brick, Uncut	Pkg of 1	832-0550	
		Pkg of 6	832-3040	
5	Tube Support Rack		SRV7039-108	
6	Brick Retainer		SRV7033-149	
7	Ceramic Fiber Blanket, 1/2" Thick		832-3390	Y
8	Baffle Board, 8-1/8 in. W x 13 in. H	Pkg of 2	SRV7039-111	Y
9	Pedestal Riser		SRV7033-207	
10	Pedestal Base		SRV7033-163	
11	Strip, Oak Trim	No longer available	832-0560	
12	Rear Channel Assembly		SRV7039-001	
13	Tube Channel Assembly - Manifold Tubes		SRV7039-004	Y
14	Panel Assembly, Side, Right		SRV7039-002	
15	Tube Channel Top - Access Cover		SRV7039-114	
	Component Pack		7039-011	

Additional service part numbers appear on following page.

Beginning Manufacturing Date: July 2007

Ending Manufacturing Date: Feb 2020

Reactivation Date: April 2022

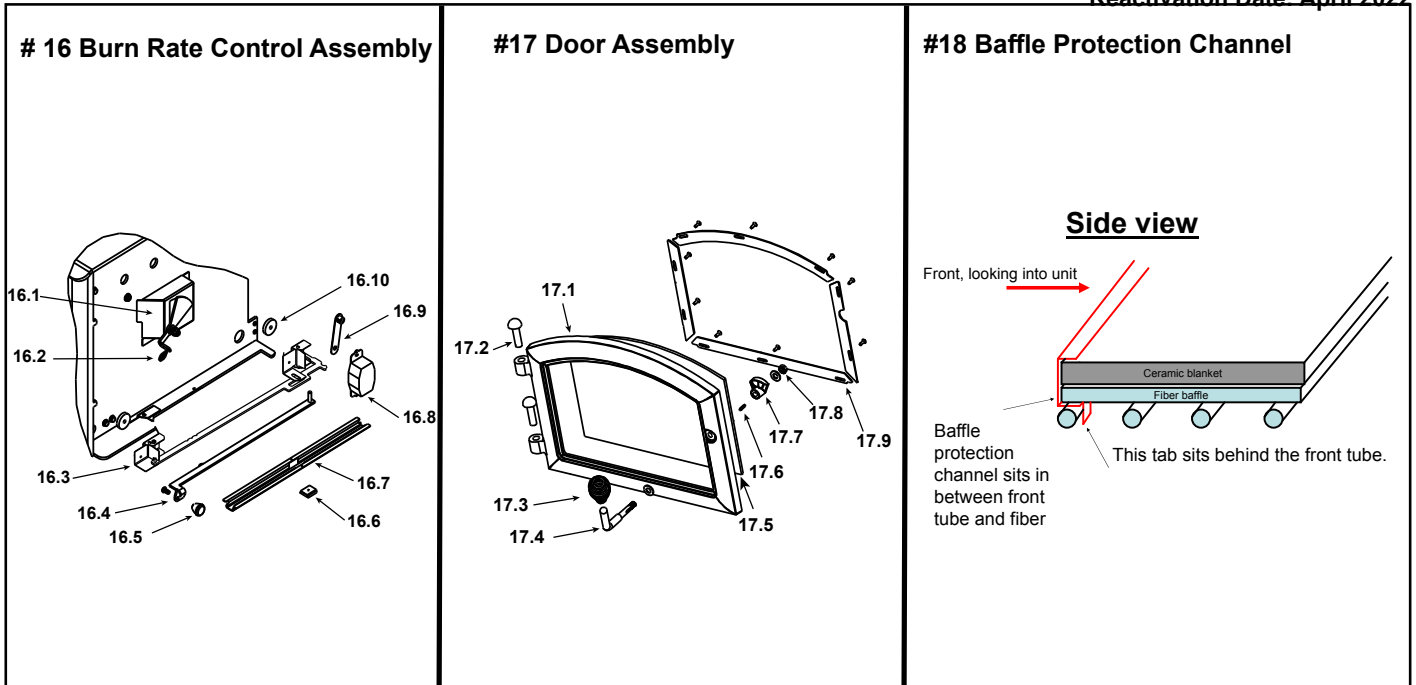

IMPORTANT: THIS IS DATED INFORMATION. When requesting service or replacement parts for your appliance please provide model number and serial number. All parts listed in this manual may be ordered from an authorized dealer.



Stocked at Depot

ITEM	DESCRIPTION	COMMENTS	PART NUMBER	
16.1	Burn Rate Control Assembly	21M-ACC-AU	SRV7039-016	
		21M-ACC-NZ	SRV7039-023	
16.2	Spring Handle, 1/4" Black		SRV7000-614	Y
16.3	Timer Air Control Assembly		SRV7039-021	Y
16.4	Rear Air Control Arm Assembly		SRV7039-006	
16.5	Start-Up Control Knob		SRV7000-343	
16.6	Latch, Magnet - for Air Control		SRV229-0631	
16.7	Air Control Rod Guide		SRV7033-210	
16.8	Timer (Only) Replacement Assembly		SRV480-1940	Y
16.9	Timer Arm Assembly		SRV7033-034	Y
16.10	Door Gasket - Front Air Timer Door		7033-282	Y
17.1	Door Assembly	Black	SRV7039-008	
17.2	Hinge Pins, 1/2"	Black	7000-606/2	
17.3	Spring Handle, 1/2", Black		SRV7000-613	Y
17.4	Door Handle Only		SRV430-1131	
17.5	Glass Assembly - 14-1/8 in. W x 9-13/16 in. H		SRV7000-013	Y
17.6	Key, Cam Latch		SRV430-1151	
17.7	Cam Latch		SRV430-1141	
17.8	Nut, Locking Door Handle	Pkg of 24	226-0100/24	Y
17.9	Frame, Glass, Top		GL-FRM-21M	
18	Baffle Protection Channel		SRV7039-144	Y

Additional service part numbers appear on following page.

QUADRA-FIRE®

NOTHING BURNS LIKE A QUAD

CONTACT INFORMATION

Hearth & Home Technologies
 352 Mountain House Road
 Halifax, PA 17032
 Division of HNI INDUSTRIES

Please contact your Quadra-Fire dealer with any questions or concerns.
 For the number of your nearest Quadra-Fire dealer
 log onto www.quadrafire.com



CAUTION



DO NOT DISCARD THIS MANUAL

- Important operating and maintenance instructions included.
- Read, understand and follow these instructions for safe installation and operation.
- Leave this manual with party responsible for use and operation of this appliance.



We recommend that you record the following pertinent information for your heating appliance.

Date purchased/installed: _____

Serial Number: _____ Location on appliance: _____

Dealership purchased from: _____ Dealer Phone: 1() - _____

Notes: _____

This product may be covered by one or more of the following patents: (United States) 5341794, 5263471, 6688302, 7216645, 7047962 or other U.S. and foreign patents pending.

