

HEAT & GLO™

No one builds a better fire

INSTALLATION AND OPERATION INSTRUCTIONS

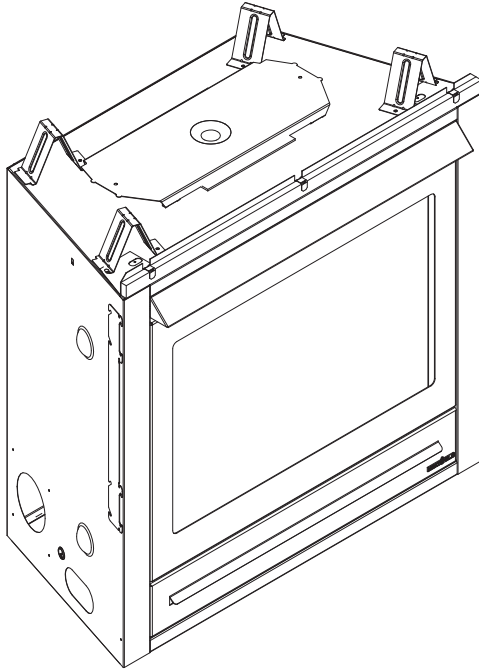

MODEL: SL-350TRSI-AUE

AUSTRALIAN GAS ASSOCIATION CERTIFIED
CERTIFICATE NUMBER 7060

**THIS MANUAL MUST BE USED FOR INSTALLATION AND RETAINED
BY HOMEOWNER FOR OPERATION AND MAINTENANCE.**

HEAT & GLO, a brand of Hearth & Home Technologies Inc.
7571 215th Street West, Lakeville, MN 55044, USA, www.heatnglo.com

→ This product is covered by one or more of the following patents: (United States) 5328356, 5601073, 5613487, 5647340, 5890485, 5941237, 5947112, 5996575, 6006743, 6019099, 6053165, 6145502, 6170481, 6374822, 6484712, 6601579, 6769426, 6863064, 7077122, 7098269, 7258116, 7470729 or other U.S. and foreign patents pending.

HEAT & GLO™

No one builds a better fire

PLEASE READ THIS MANUAL BEFORE INSTALLING
AND USING THIS APPLIANCE.

MODEL SL-350TRSI-AUE IS AUSTRALIAN GAS ASSOCIATION APPROVED FOR NATURAL GAS OR PROPANE AS A BALANCED FLUE HEATER.

Refer to the appliance data plates for gas consumptions and pressures.

Installation of this appliance should only be carried out by an authorized person in accordance with the manufacturer's instructions. Appliance is to be installed in full compliance with the National Gas Installation Standard AS5601, the manufacturer's instructions, and any local authorities' requirements for gas, electrical and building regulations.

This appliance and its components are tested and safe when installed in accordance with this Installation Manual. Report to your dealer any parts damaged in shipment, specifically check glass condition. The gas logs and flue system components are in separate packages. Read all instructions before starting installation and

follow these instructions carefully during installation to ensure maximum benefit and safety. Failure to follow them will void your warranty and may present a fire hazard.

The Heat & Glo, a brand of Hearth & Home Technologies Inc. warranty will be voided by, and Heat & Glo, a brand of Hearth & Home Technologies Inc. disclaims any responsibility for the following actions:

- Installation of any damaged heater or flue system component
- Modification of the heater or balanced flue system installation other than as instructed by Heat & Glo, a brand of Hearth & Home Technologies Inc.
- Improper positioning of the gas logs or the glass door
- Installation and/or use of any component part not manufactured or approved by Heat & Glo, brand of Hearth & Home Technologies Inc., notwithstanding any independent testing laboratory or other party approval of such component part or accessory.

IMPORTANT: Read all instructions carefully before starting installation. Failure to follow these installation instructions may result in a possible fire hazard and will void the warranty. Save this manual for future reference.

Heat & Glo, a brand of Hearth & Home Technologies, Inc.
7571 215th Street West, Lakeville, MN 55044
Copyright 2009 • Printed in U.S.A.

TABLE OF CONTENTS

1.0	Installation Instructions	5
1.1	Introduction	6
1.2	Flue System Approvals and Installation.....	8
1.3	Connecting the Gas Supply	23
1.4	Ignition System Wiring	24
1.5	Blower	25
1.6	Finishing	26
1.7	Installer Testing.....	27
1.8	Log Placement.....	28
2.0	Operating Instructions	31
2.1	Safety and Lighting Information.....	32
2.2	Power Outage.....	33
2.3	Fan Operation.....	33
3.0	Servicing and Maintenance.....	33
3.1	Removal of Covers for Servicing	34
3.2	Removal of Components for Service	34
3.3	Parts Replacement	34
3.4	Adjustments and Replacement Parts	34
3.5	Maintenance Tasks	35
3.6	Troubleshooting	36
4.0	Replacement Parts	37
	Limited Lifetime Warranty	40

→ = Contains updated information.

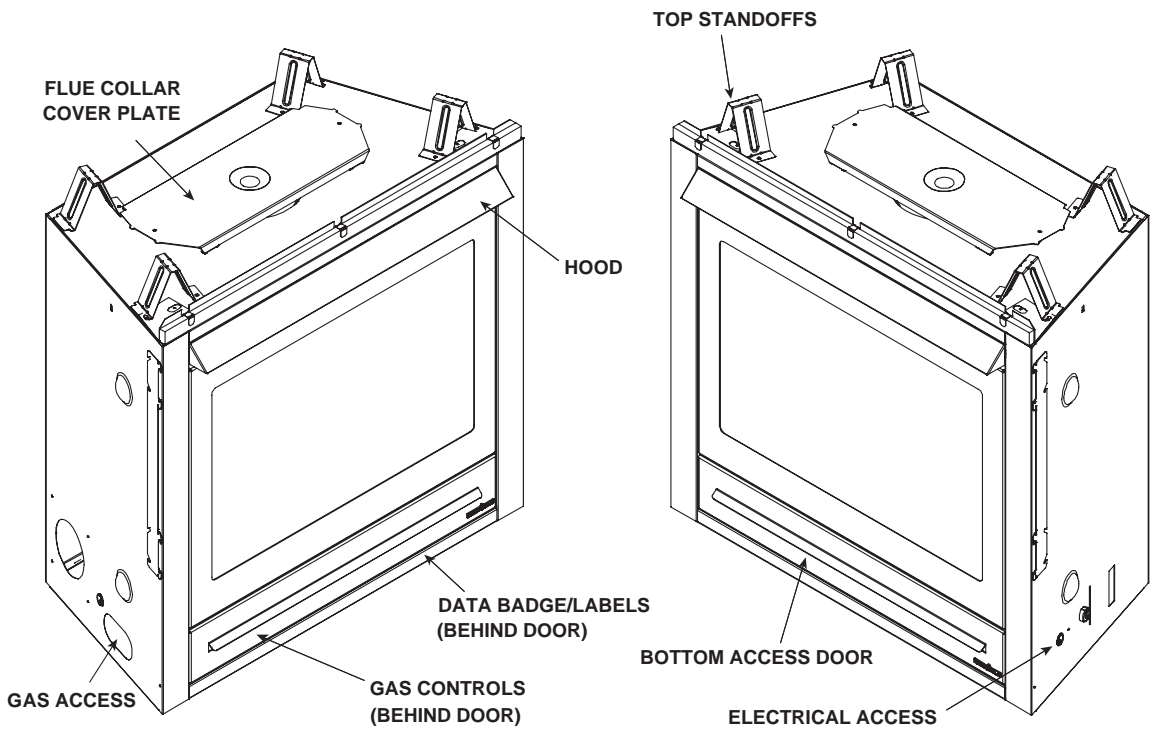
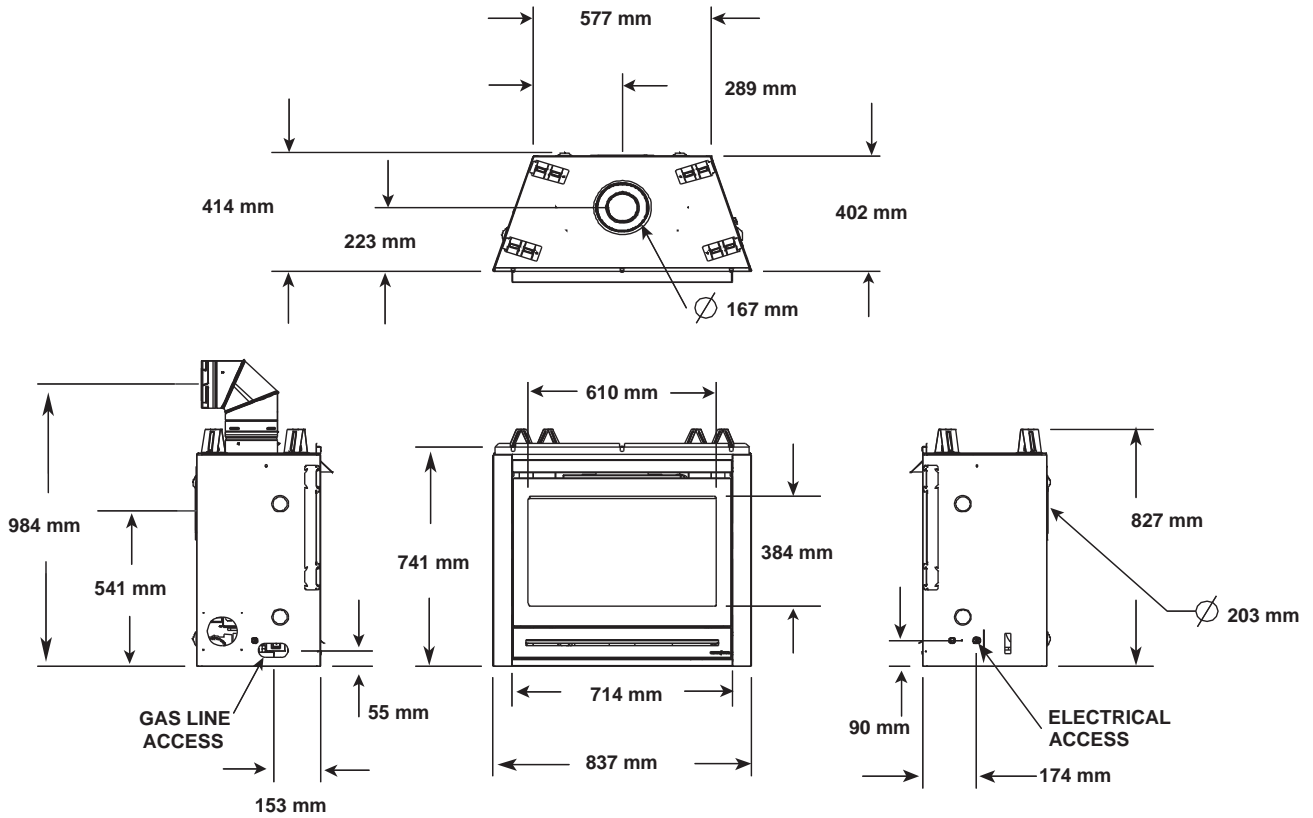

Figure 1. Diagram of SL-350TRSI-AUE

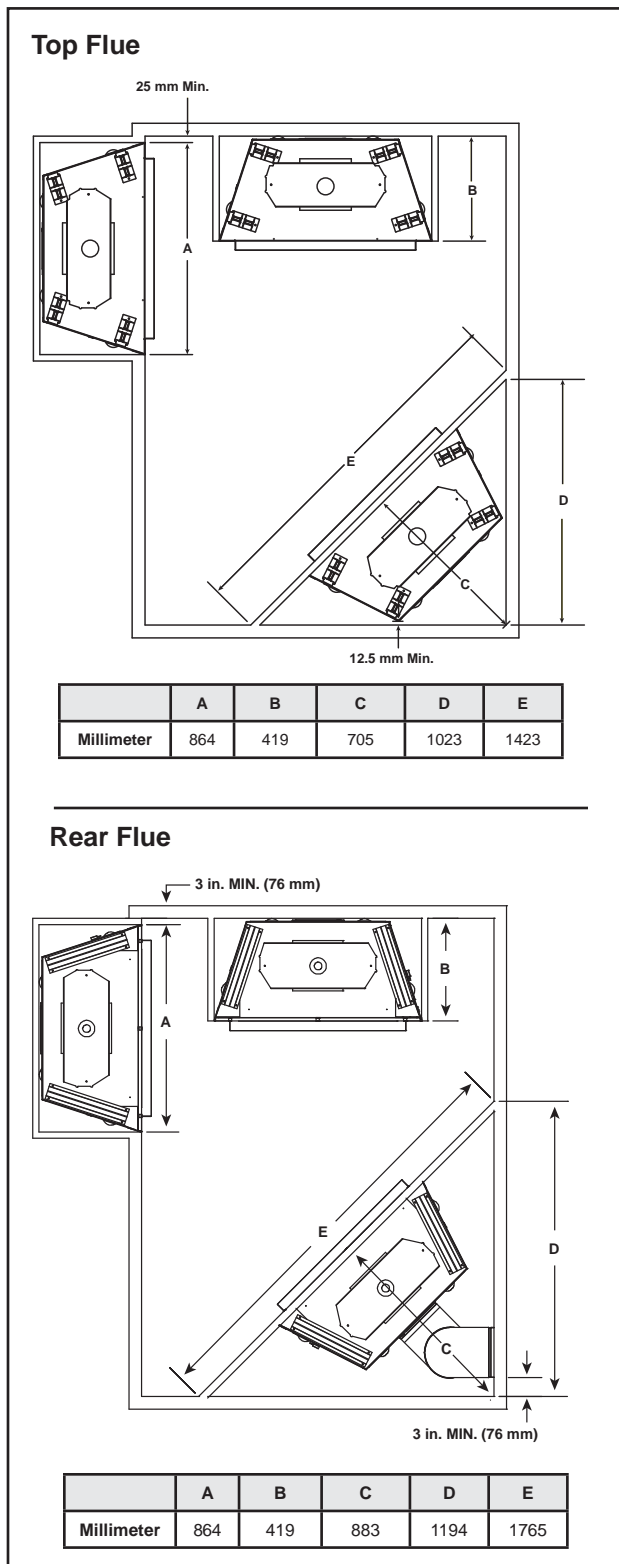

Figure 2. Heater Dimensions, Locations, and Space Requirements

Clearance Requirements

The top and back of heater are defined by stand-offs.

The heat shield must be attached as shown if combustible materials are placed directly on top standoffs (Figure 3).

The minimum clearance to a perpendicular wall extending past the face of the heater is 25 mm.

The back of the heaters may be recessed into combustible construction, as shown above.

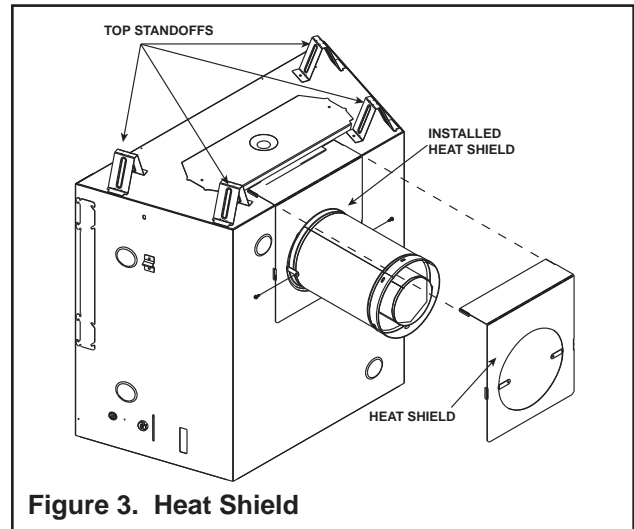

Figure 3. Heat Shield

1.0 INSTALLATION INSTRUCTIONS

NOTE: Not intended for heater insert.

In planning the installation for the heater it is necessary to determine where the unit is to be installed, the type of flue system to be used (straight out, corner, or elevated), and whether optional accessories (wall switch or remote control) are desired. Gas supply piping should also be planned. Refer to the appliance data plate on the base pan of the heater for all gas pressures and input rate information.

The heater can be mounted on any of the following surface:

1. A flat surface (minimum 6 mm base).
2. Four (4) corner supports.

(Example: Four (4) concrete masonry blocks). These supports must be positioned so they contact all four (4) perimeter edges on the bottom of the unit.

Heater framing can be built before or after the heater is set in place. Framing should be positioned to accommodate wall covering and heater facing material. The heater framing should be constructed of 2" X 4" (51 x 102 mm) lumber or heavier. The framing headers may rest on the heater standoffs. Refer to Figure 2 and Figure 4 for heater and framing reference dimensions.

Minimum Clearances from the Heater to Combustible Materials	
Glass Front	914 mm
Floor	0 mm
Rear.....	13 mm
Sides.....	13 mm
Top	86 mm
Ceiling*	787 mm

*The clearance to ceiling is measured from the top of the unit, excluding the standoffs (see Figure 44).

Minimum Clearances from the Vent Pipe to Combustible Materials	
Vertical Sections	25 mm
Horizontal Sections	
Top.....	75 mm
Bottom	25 mm
Sides.....	25 mm
At Wall Firestops	
Top.....	75 mm
Bottom	25 mm
Sides.....	25 mm

For minimum clearances, see the balanced flue termination clearance in Figure 5.

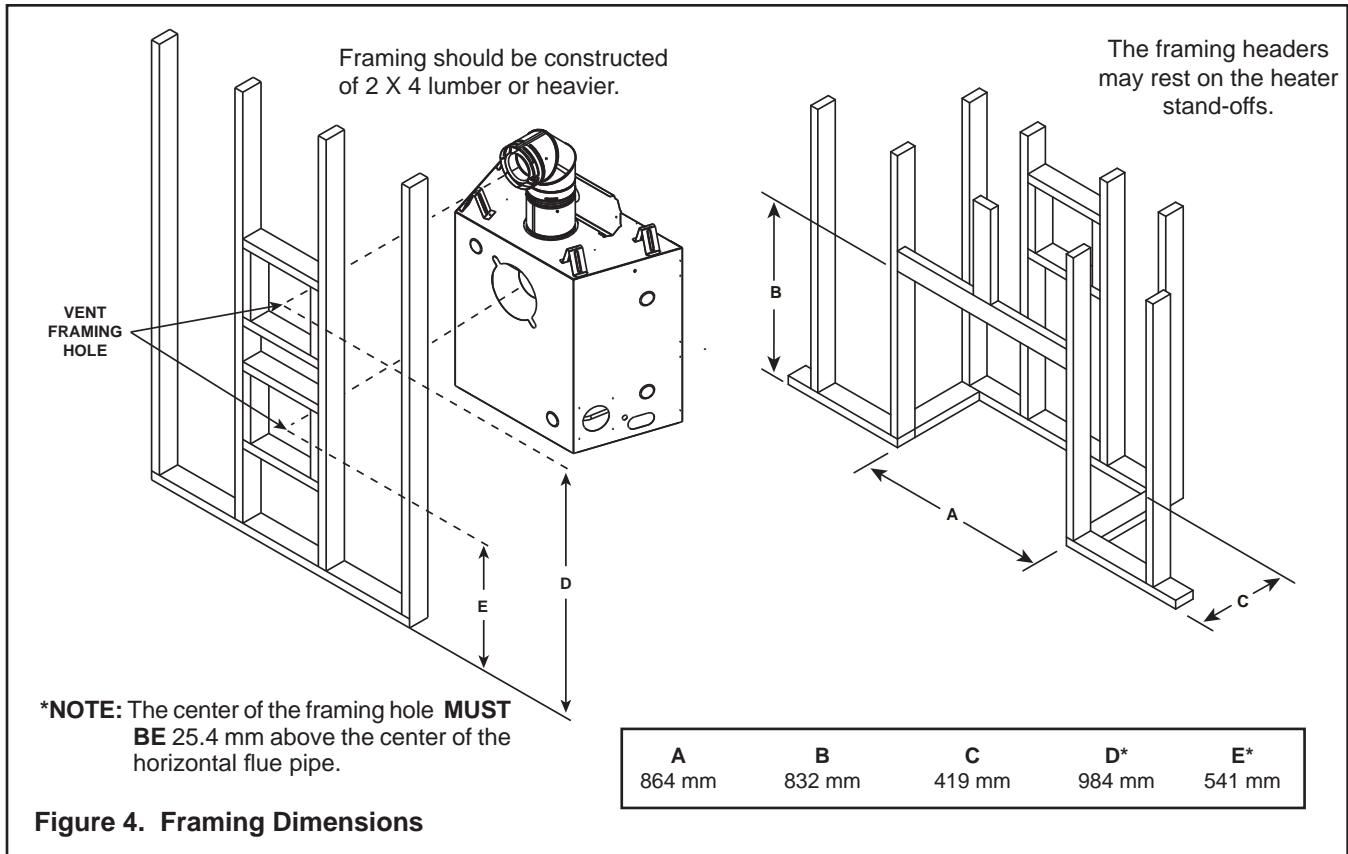

CAUTION: Measure heater dimensions, and verify framing methods and wall covering details before framing construction begins.

1.1 INTRODUCTION

This model is designed to operate with all combustion air being siphoned from the outside of the building and all exhaust gases expelled to the outside of the building.

WARNING: THIS UNIT IS NOT FOR USE WITH SOLID FUEL.

These units **MUST** use the flue termination described in the flueing section of the manual.

The control system for this model is an electronic ignition type. It consists of a gas control valve/variable regulator, a pilot/sensor/electrode and an ON/OFF switch. The controls are located behind the access door. Rotate the door down to open. See Figure 1.

Minimum inlet gas supply pressure for purpose of input adjustment is 1.13 kPa for natural gas and 2.75 kPa for propane. Manifold (outlet) pressures should be set at .8 kPa for natural gas models and 2.36 kPa for propane models.

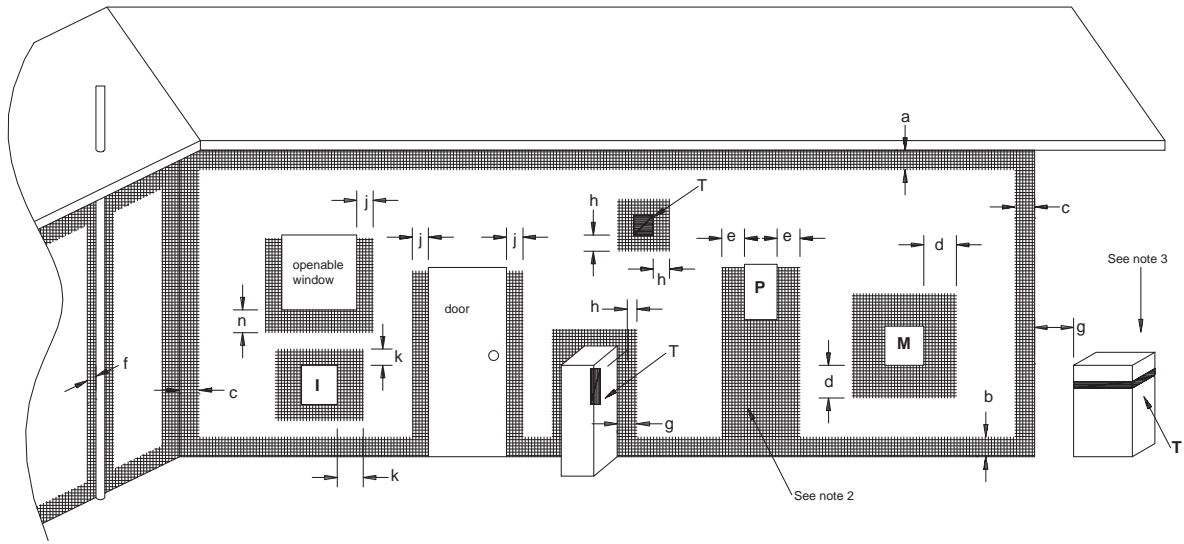

T = Flue terminal
 I = Mechanical air inlet
 M = Gas meter
 P = Electricity meter or fuse box
 Shading indicates prohibited areas for flue terminals

- MIN. CLEARANCE (mm)**
- a - Below eaves, balconies or other projections:
 - Appliances to 50 MJ/h input300
 - Appliances over 50 MJ/h input500
 - b - From the ground or above a balcony300
 - c - From a return wall or external corner500
 - d - From a gas meter (M)1000
 - e - From an electricity meter or fuse box (P)500
 - f - From a drain or soil pipe150
 - g - Horizontally from any building structure (unless appliance approved for closer installation) or obstruction facing a terminal500
 - h - From any other flue terminal, cowl, or combustion air intake500
 - j - Horizontally from an openable window, door, non-mechanical air inlet, or any other opening into a building, with the exception of sub-floor ventilation:
 - Appliances up to 150 MJ/h input500
 - Appliances over 150 MJ/h input1500
 - k - From a mechanical air inlet, including a spa blower1500
 - n - Vertically below an openable window, non-mechanical air inlet or any other opening into a building, with the exception of See table sub-floor ventilation below

CLEARANCE 'n' (mm)			
Space Heaters	All other appliances		
Up to 50 MJ/h input	Up to 50 MJ/h input	Over 50 MJ/h input and Up to 150 MJ/h input	Over 50 MJ/h input
150	500	1000	1500

- NOTES:**
1. All distances are measured vertically or horizontally along the wall to a point in line with the nearest part of the terminal.
 2. Prohibited area below electricity meter or fuse box extends to ground level.
 3. See clause 5.13.6.6 for restrictions on a flue terminal under a roofed area.
 4. See Appendix J, Figure J1(a) and J2(a) for clearances required from a flue terminal to a LP Gas cylinder. A flue terminal is considered to be a source of ignition.

MINIMUM CLEARANCES REQUIRED FOR BALANCED FLUE TERMINALS OR THE FLUE TERMINALS OF OUTDOOR APPLIANCES

Figure 5.

TABLE 1

MODEL SL-350TRSI-AUE	FLUE TERMINATION APPROVALS DVP-TRAP2 & SLP-TRAP2 HORIZONTAL TERMINATION CAP DVP-TVHW & SLP-TVHW VERTICAL TERMINATION CAP
--------------------------------	---

1.2 FLUE SYSTEM APPROVALS

These models have flue starting collars on both the top and the back of the unit. Depending upon the installation, decide which **ONE** set of starting collars will be used to attach the flue system. The starting collar sealing cap must remain on the starting collar NOT used.

These models use SLP series direct flue components when using the **TOP** flue collars and DVP-series direct flue components when using the **REAR** flue collars.

WARNING: YOU MUST NOT MIX DVP-SERIES AND SLP SERIES COMPONENTS IN ANY FLUE SYSTEM CONFIGURATION.

Approved flue system components are labeled for identification. **NO OTHER FLUEING SYSTEMS OR COMPONENTS MAY BE USED.** Detailed installation instructions are included with each flue termination kit and should be used in conjunction with this *manual*. Figure 5 below shows flue system components and terminations.

Identifying Flue Components

The flue systems installed on this gas heater may include one, two, or three 90° elbow assemblies. The relationships of vertical rise to horizontal run in flue configurations using 90° elbows **MUST BE** strictly

adhered to. The rise to run relationships are shown in the flueing drawings and tables on the next few pages.

WARNING: THIS GAS APPLIANCE AND FLUE ASSEMBLY MUST FLUE DIRECTLY TO THE OUTSIDE AND MUST NEVER BE ATTACHED TO A CHIMNEY SERVING A SEPARATE SOLID FUEL BURNING APPLIANCE. EACH GAS APPLIANCE MUST USE A SEPARATE FLUE SYSTEM-COMMON FLUE SYSTEMS ARE PROHIBITED.

CAUTION: UNDER NO CONDITION SHOULD COMBUSTIBLE MATERIAL BE CLOSER THAN 76 mm AT WALL FIRE-STOPS FROM THE TOP OF THE PIPE OR 25 mm TO THE SIDES AND THE BOTTOM FOR HORIZONTAL SECTIONS OF THIS FLUE SYSTEM. VERTICAL SECTIONS OF THIS SYSTEM REQUIRE A MINIMUM OF 25 mm CLEARANCE TO COMBUSTIBLE MATERIALS ALL AROUND THE PIPE.

For alternative installations, other than depicted, contact your dealer for further information.

Refer to Figure 5 for required clearances to flue terminals.

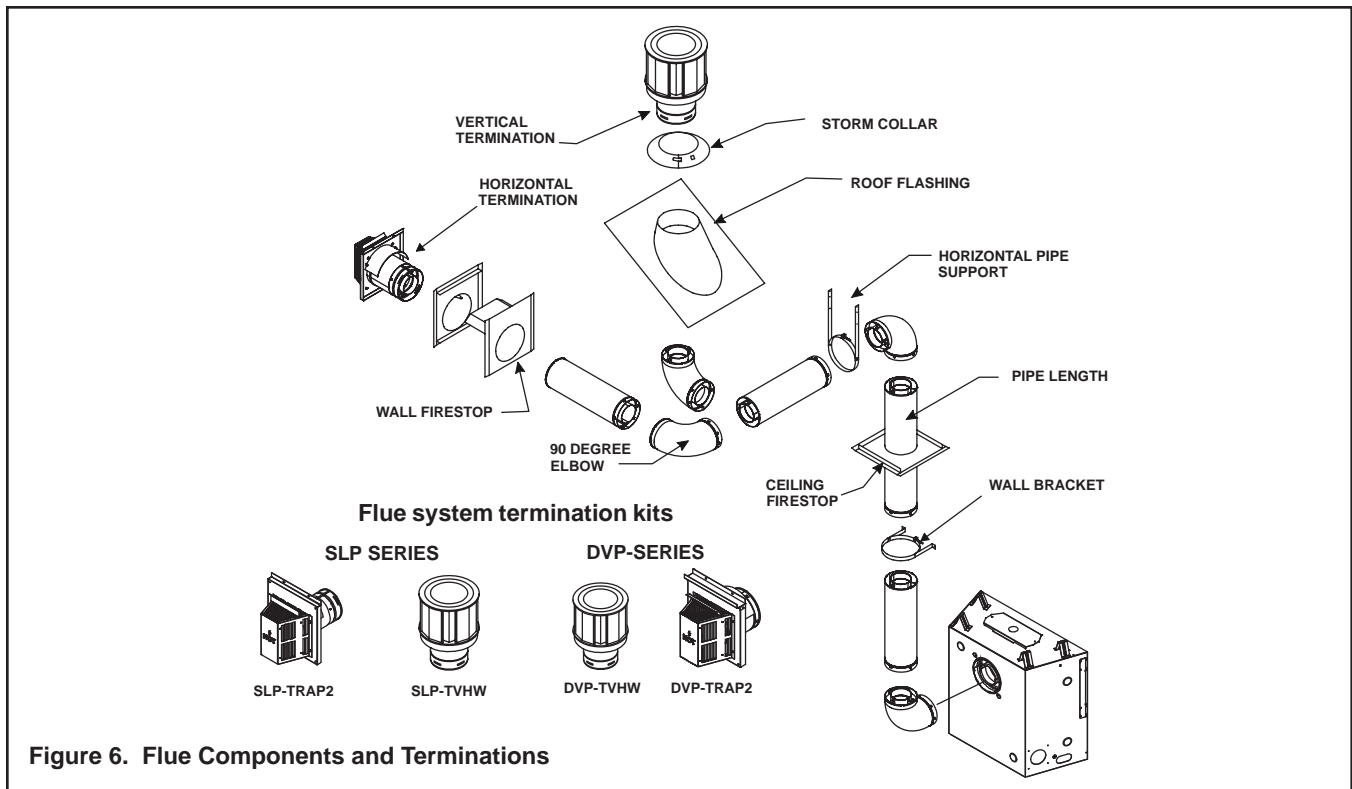

Figure 6. Flue Components and Terminations

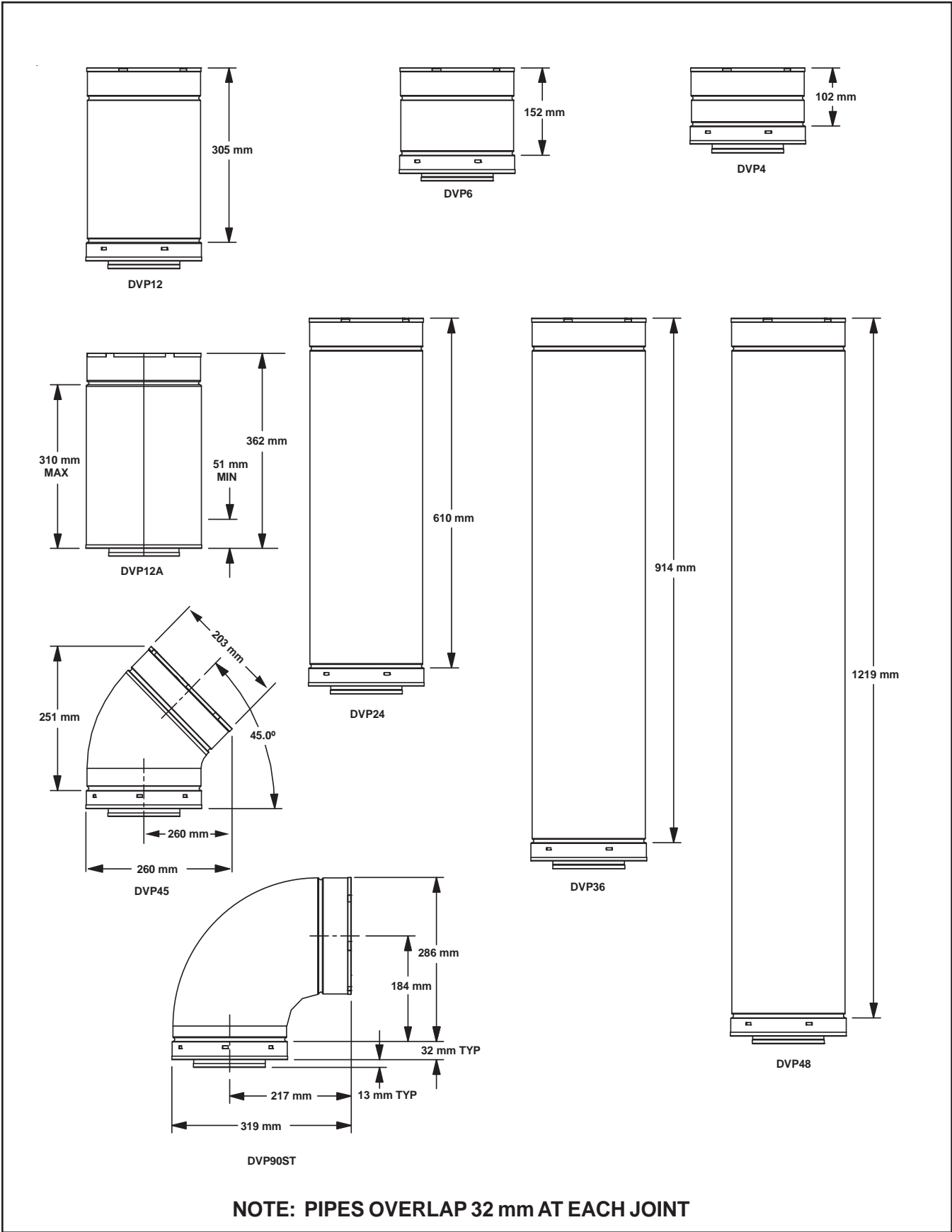
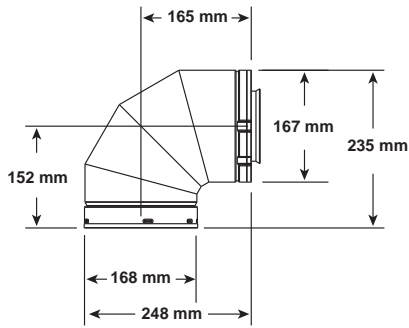
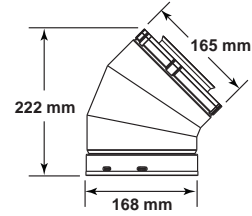

Figure 7. DVP-Series Balanced Flue Component Specifications (127 mm inner pipe / 203 mm outer pipe)



SLP90



SLP45

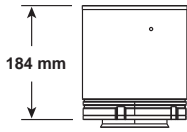

SLP6A

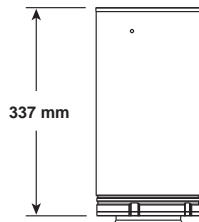

SLP12A



SLP4

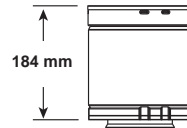

SLP6

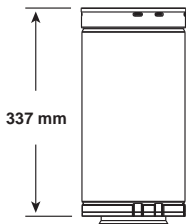

SLP12

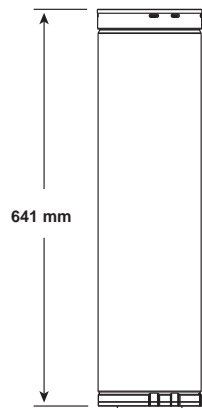

SLP24

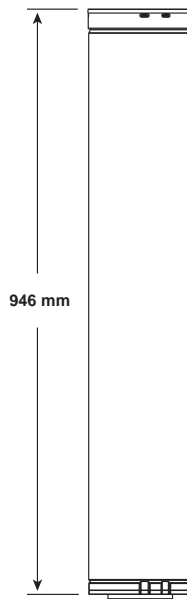

SLP36

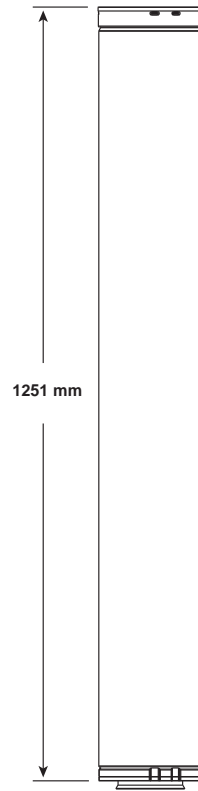

SLP48

Note: Pipes overlap 34.93 mm at each joint.

Figure 8. SLP Series Balanced Flue Component Specifications (102 mm inner pipe / 168 mm outer pipe)

Vertical Flue Restrictor

If the heater installation requires a vertical flue exceeding 4.5 m above the unit with no horizontal flue or elbows, a vertical flue restrictor must be installed (see Figure 9).

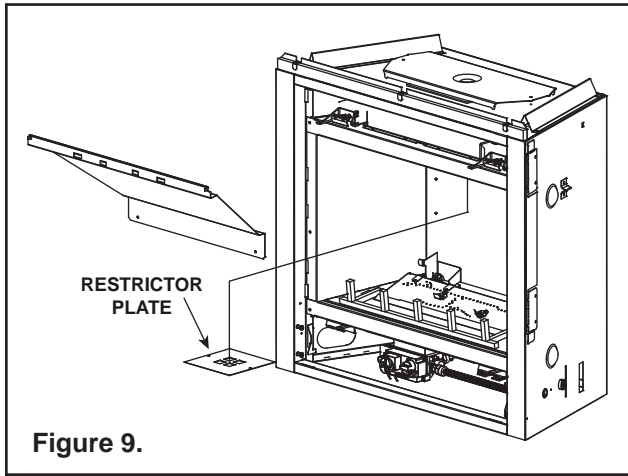

Figure 9.

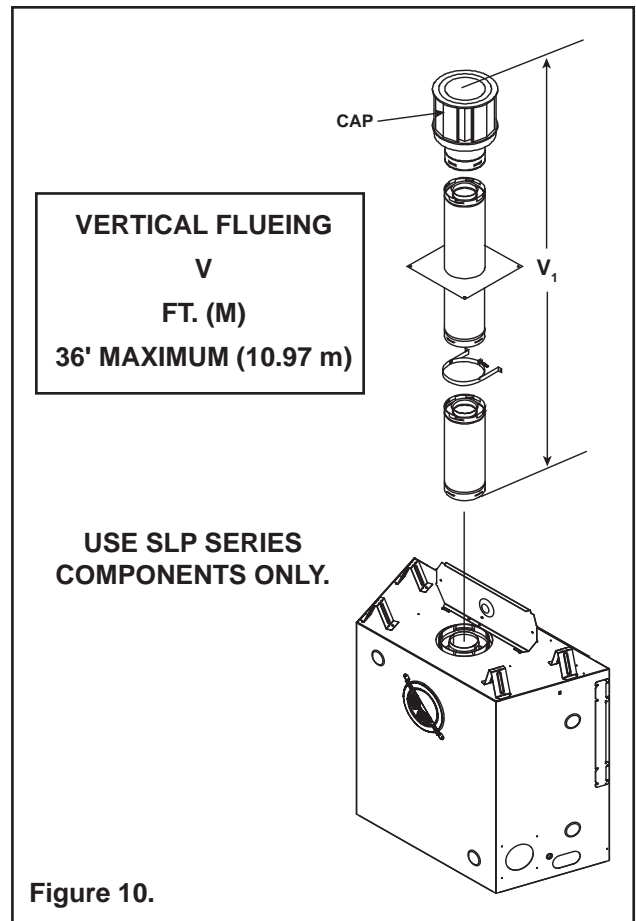

Figure 10.

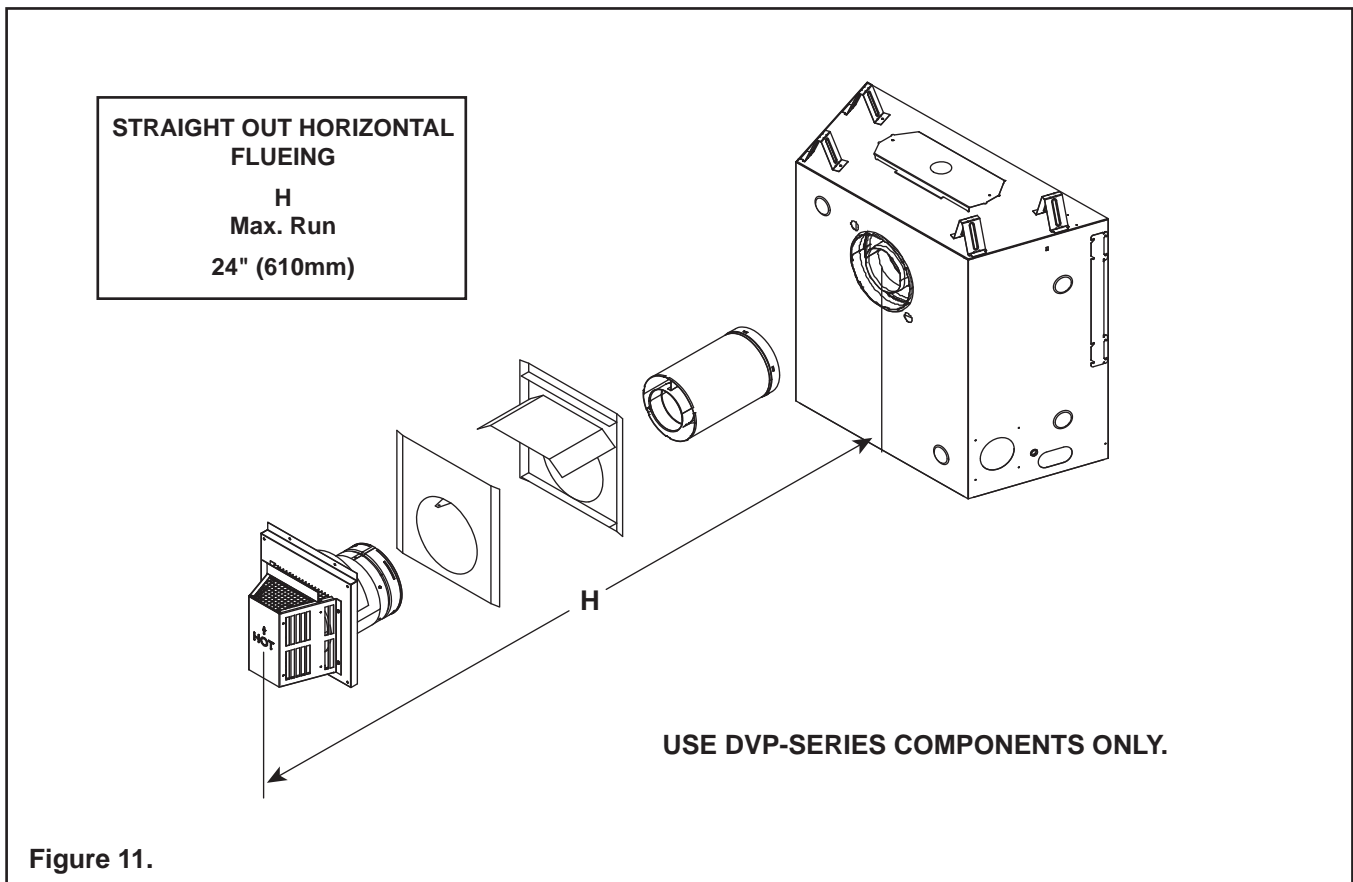
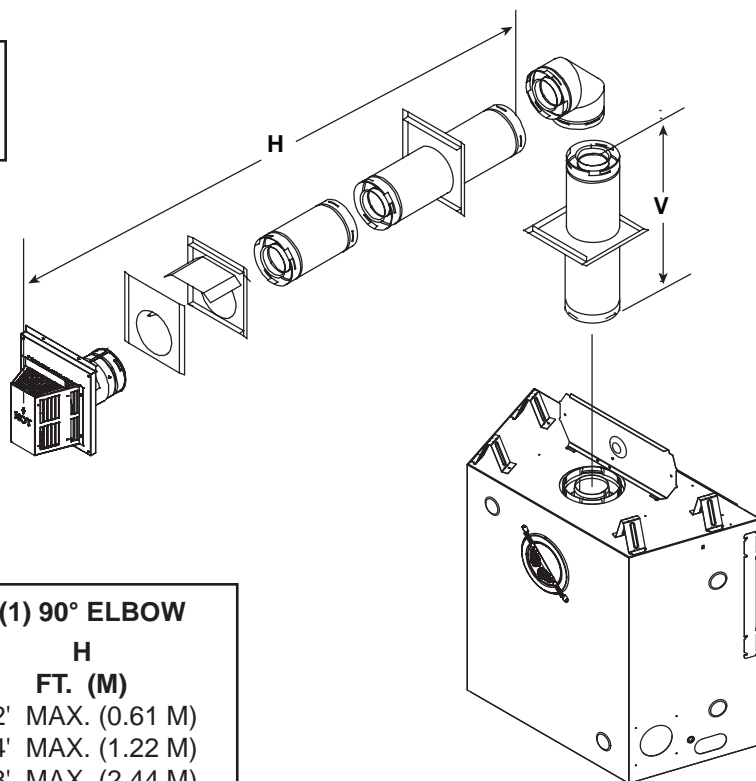

Figure 11.

NOTE: A 184 mm section of straight flue must be attached to the heater before a 90° elbow.

USE SLP SERIES COMPONENTS ONLY.



FLUEING WITH ONE (1) 90° ELBOW	
V	H
FT. (M)	FT. (M)
1' MIN. (0.30 M)	2' MAX. (0.61 M)
2' MIN. (0.61 M)	4' MAX. (1.22 M)
3' MIN. (0.91 M)	8' MAX. (2.44 M)
4' MIN. (1.22 M)	10' MAX. (3.05 M)
V + H = 30' (9.14 M)	

Figure 12.

FLUEING WITH ONE (1) 90° ELBOW

V (FT.)	H (FT.)
1' MIN. (0.30 M)	3' MAX. (0.91 M)
2' MIN. (0.61 M)	6' MAX. (1.83 M)
3' MIN. (0.91 M)	9' MAX. (2.74 M)
4' MIN. (1.22 M)	12' MAX. (3.66 M)
V+H = 36' MAX. (10.97 M) H = 12' MAX. (3.66 M)	

USE DVP-SERIES COMPONENTS ONLY.

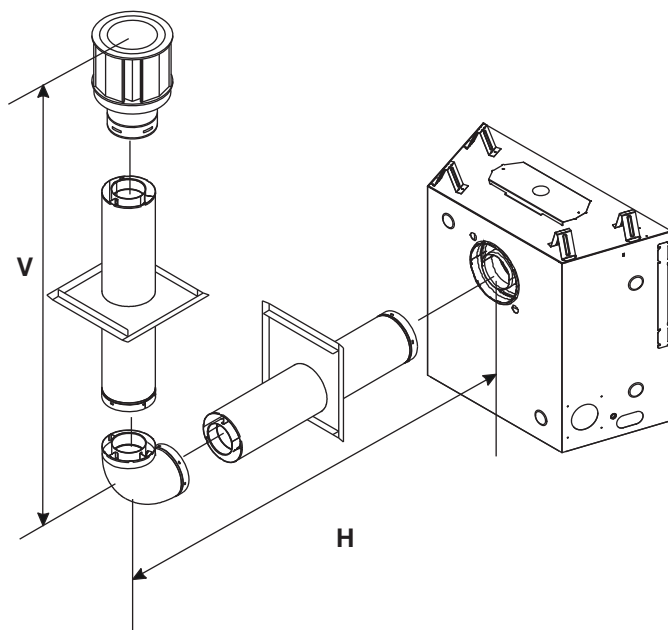
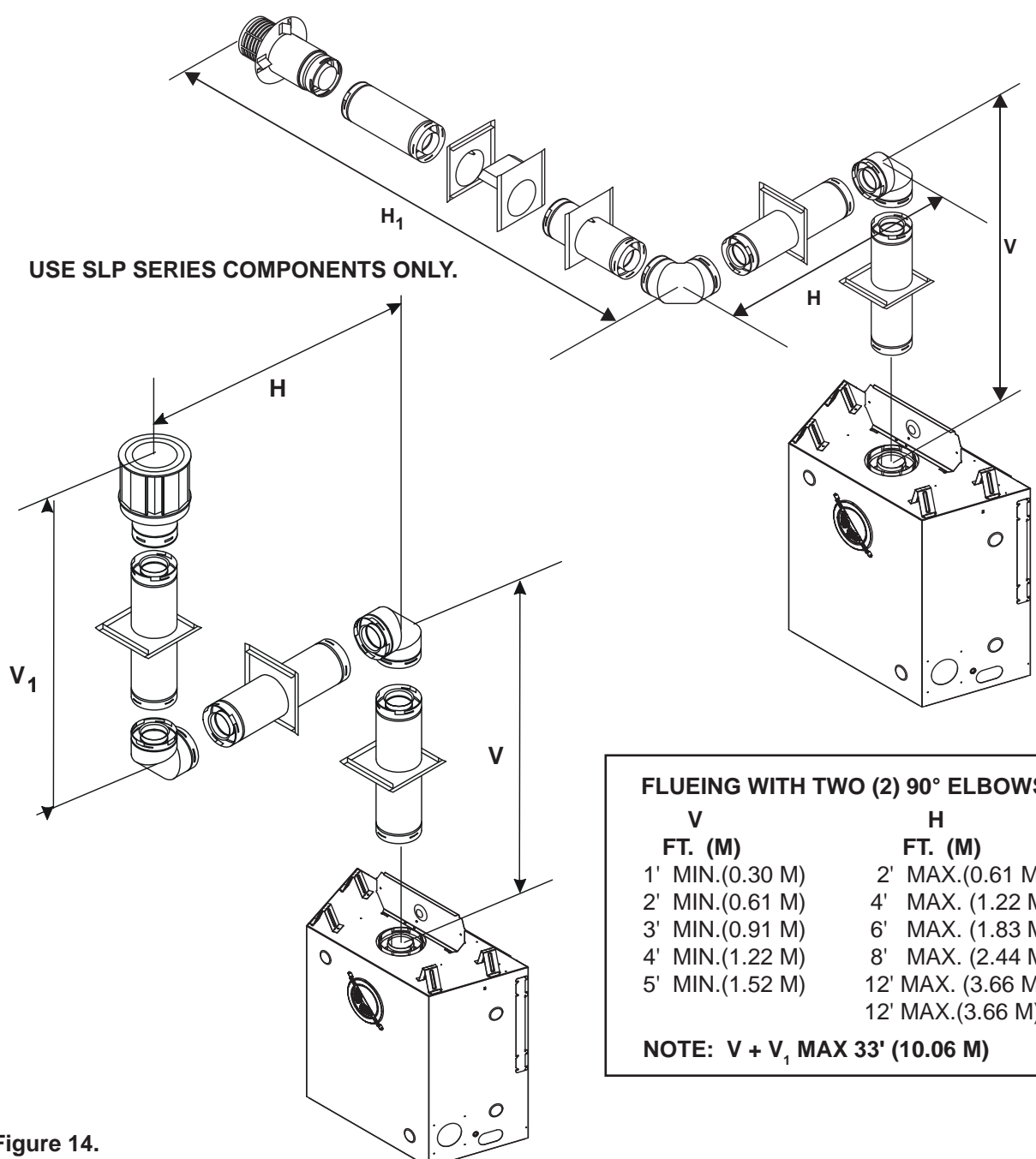

Figure 13.

FLUEING WITH TWO (2) 90° ELBOWS

V FT. (M)	H + H₁ FT. (M)
1' MIN.(0.30 M)	2' MAX.(0.61 M)
2' MIN.(0.61 M)	4' MAX.(1.22 M)
3' MIN.(0.91 M)	6' MAX.(1.83 M)
4' MIN.(1.22 M)	8' MAX.(2.44 M)
5' MIN.(1.52 M)	10' MAX. (3.05 M)
30' MAX.(9.14 M)	10' MAX. (3.05 M)



FLUEING WITH TWO (2) 90° ELBOWS

V FT. (M)	H FT. (M)
1' MIN.(0.30 M)	2' MAX.(0.61 M)
2' MIN.(0.61 M)	4' MAX. (1.22 M)
3' MIN.(0.91 M)	6' MAX. (1.83 M)
4' MIN.(1.22 M)	8' MAX. (2.44 M)
5' MIN.(1.52 M)	12' MAX. (3.66 M)
	12' MAX.(3.66 M)

NOTE: V + V₁ MAX 33' (10.06 M)

Figure 14.

FLUEING WITH TWO (2) 90° ELBOWS

V	H	H + H ₁
1' MIN. (0.30 M)	1' MAX. (0.30 M)	2' MAX. (0.61 M)
2' MIN. (0.61 M)	2' MAX. (0.61 M)	4' MAX. (1.22 M)
3' MIN. (0.91 M)	3' MAX. (0.91 M)	8' MAX. (2.44 M)
4' MIN. (1.22 M)	4' MAX. (1.22 M)	10' MAX. (3.05 M)
H = 8' MAX. (2.44 M)		H + H ₁ = 10' MAX. (3.05 M)
V + H + H ₁ = 30' (9.14 M) MAX.		

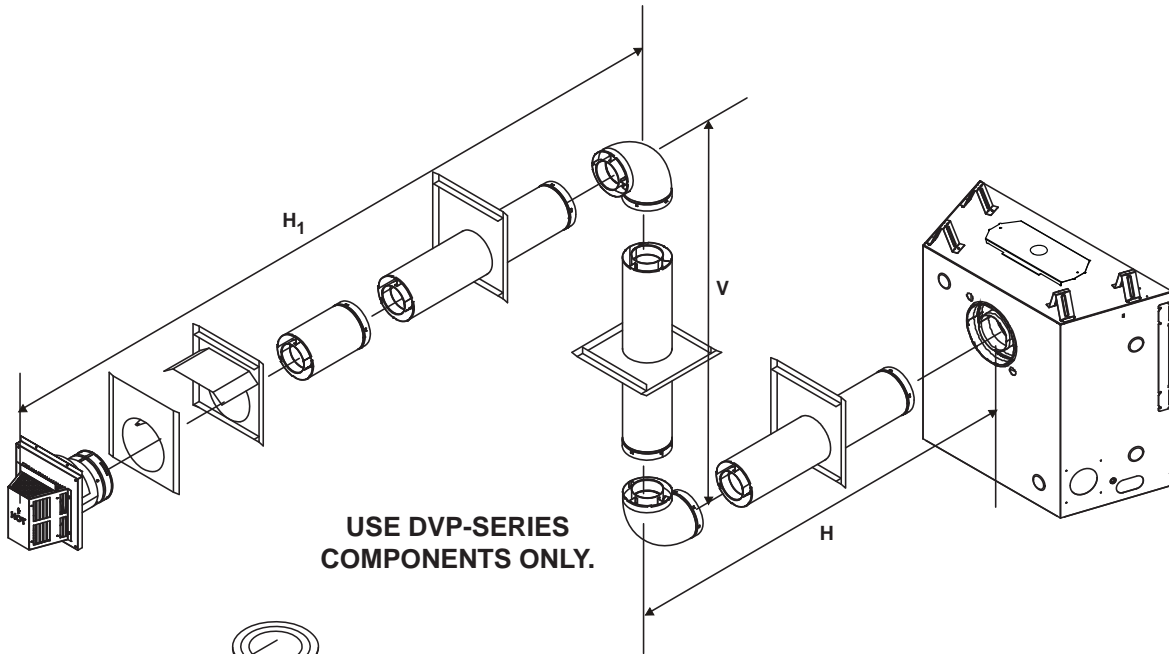

V (FT)	H + H ₁ (FT)
1' MIN. (0.30 M)	3' MAX. (0.91 M)
2' MIN. (0.61 M)	5' MAX. (1.52 M)
3' MIN. (0.91 M)	8' MAX. (2.44 M)
4' MIN. (1.22 M)	10' MAX. (3.05 M)
H + H ₁ = 10' MAX. (3.05 M)	
V + H + H ₁ = 33' (10.06 M) MAX.	

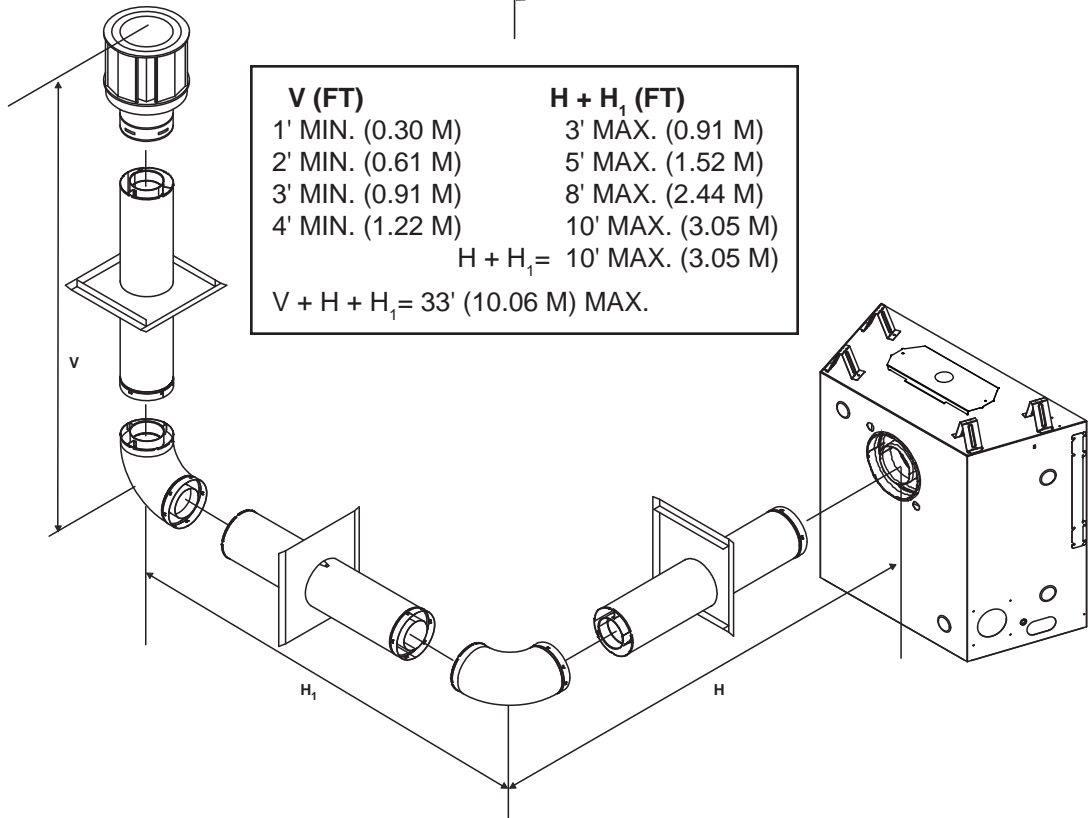
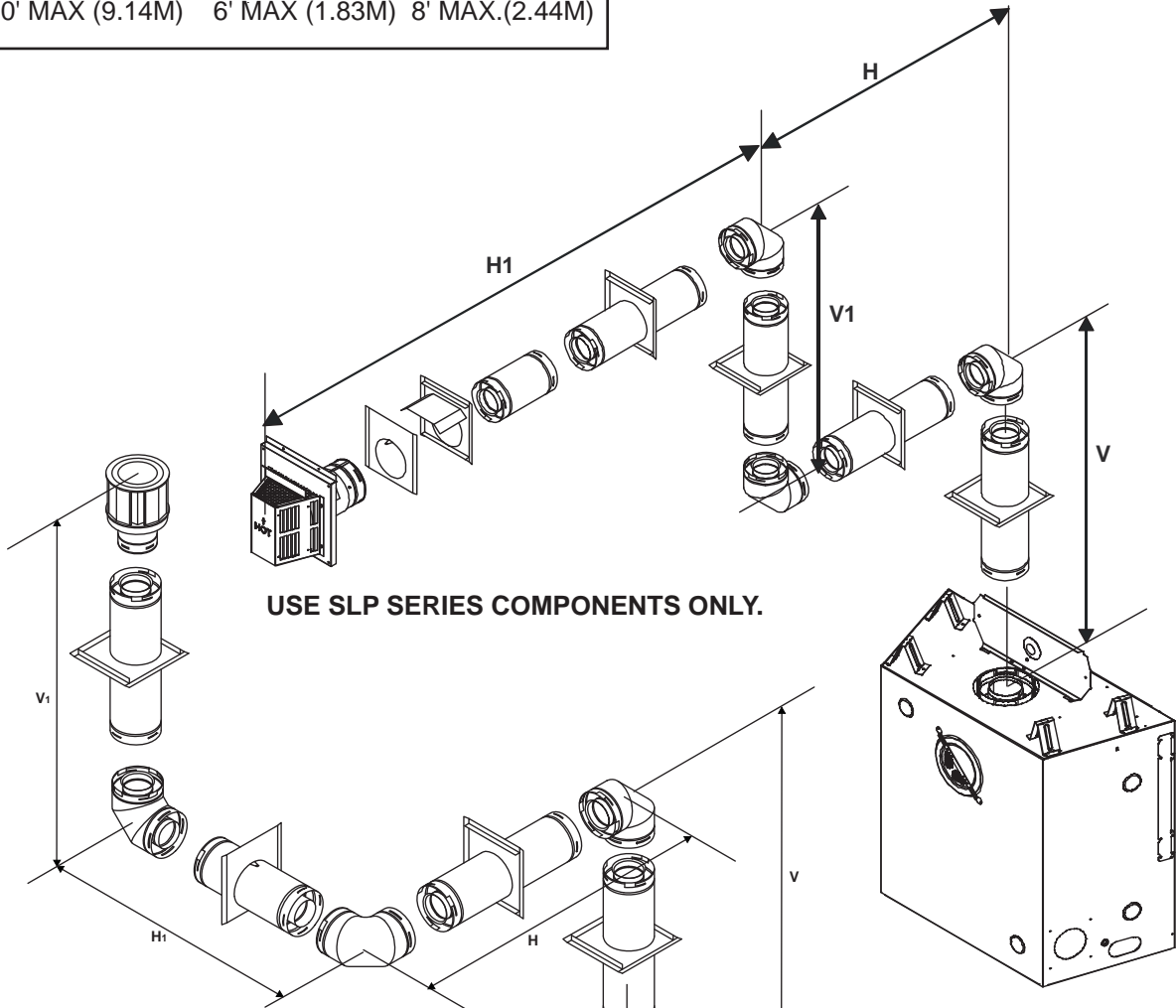

Figure 15.

FLUEING WITH THREE (3) 90° ELBOWS

V	H	H + H ₁
FT. (M)	FT. (M)	FT. (M)
2' MIN.(0.61M)	2' MAX.(0.61M)	4' MAX.(1.22M)
3' MIN.(0.91M)	3' MAX.(0.91M)	6' MAX (1.83M)
4' MIN.(1.22M)	4' MAX.(1.22M)	8' MAX.(2.44M)
V+V ₁ = 30' MAX (9.14M)		6' MAX (1.83M) 8' MAX.(2.44M)



USE SLP SERIES COMPONENTS ONLY.

FLUEING WITH THREE (3) 90° ELBOWS

V	H + H ₁
FT. (M)	FT. (M)
1' MIN.(0.30 M)	2' MAX.(0.61 M)
2' MIN.(0.61 M)	4' MAX.(1.22 M)
3' MIN.(0.91 M)	6' MAX.(1.83 M)
4' MIN.(1.22 M)	8' MAX.(2.44 M)
5' MIN.(1.52 M)	12' MAX.(3.66 M)
	12' MAX.(3.66 M)
NOTE: V + V₁ MAX. 33' (10.06 M)	

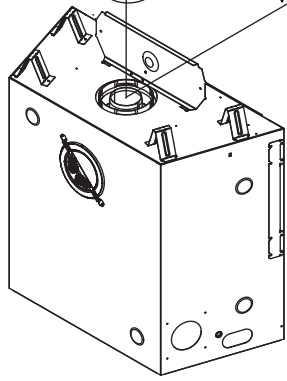
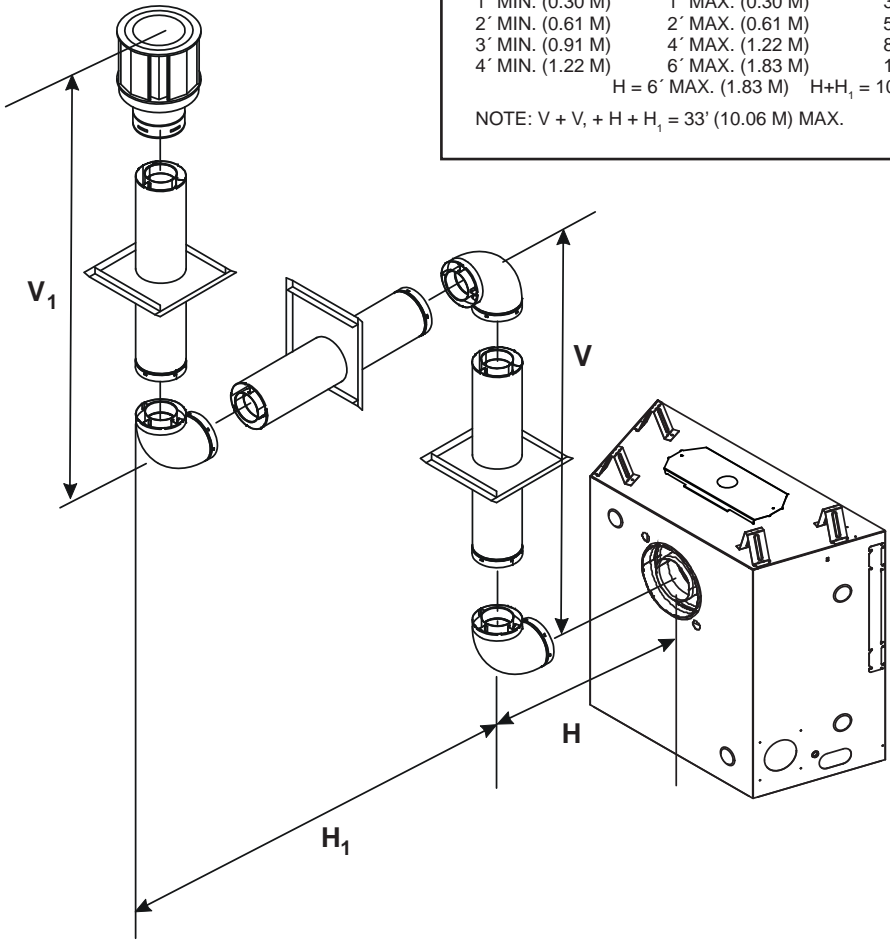

Figure 16.

FLUEING WITH THREE (3) 90° ELBOWS

V (FT.)	H (FT.)	H + H ₁ (FT.)
1' MIN. (0.30 M)	1' MAX. (0.30 M)	3' MAX. (0.91 M)
2' MIN. (0.61 M)	2' MAX. (0.61 M)	5' MAX. (1.52 M)
3' MIN. (0.91 M)	4' MAX. (1.22 M)	8' MAX. (2.44 M)
4' MIN. (1.22 M)	6' MAX. (1.83 M)	10' MAX. (3.05 M)
	H = 6' MAX. (1.83 M)	H+H ₁ = 10' MAX. (3.05 M)

NOTE: V + V₁ + H + H₁ = 33' (10.06 M) MAX.



**USE DVP-SERIES
COMPONENTS ONLY.**

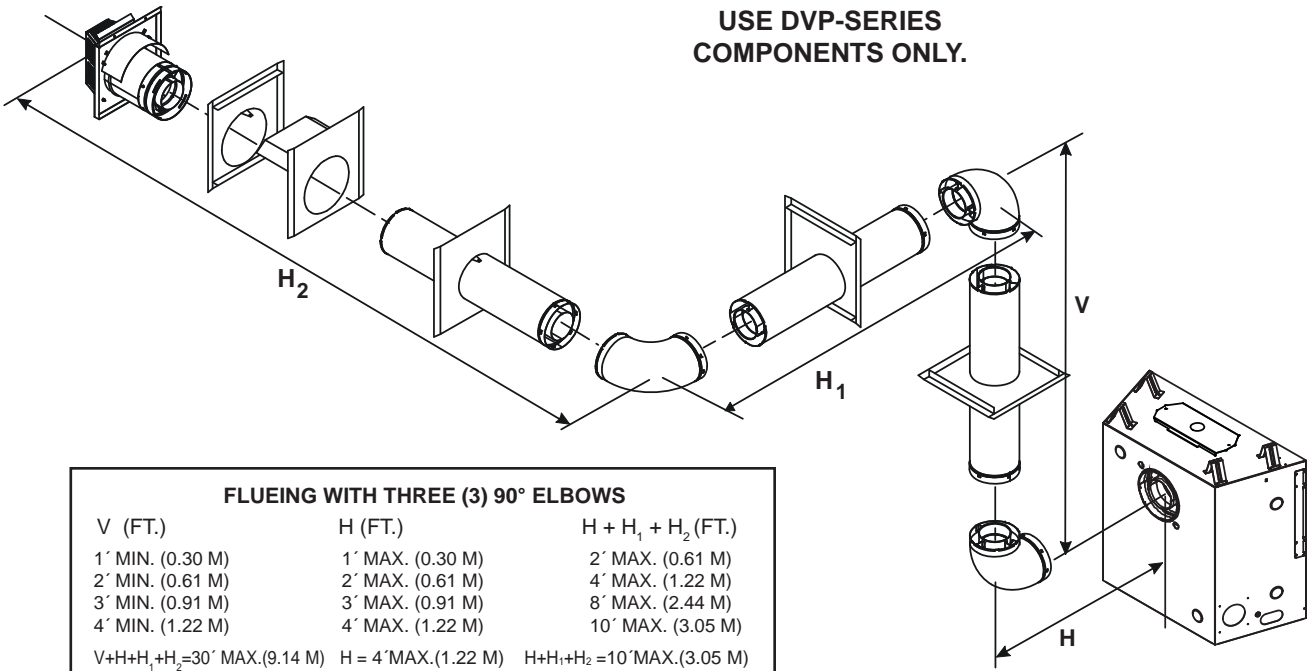

FLUEING WITH THREE (3) 90° ELBOWS

V (FT.)	H (FT.)	H + H ₁ + H ₂ (FT.)
1' MIN. (0.30 M)	1' MAX. (0.30 M)	2' MAX. (0.61 M)
2' MIN. (0.61 M)	2' MAX. (0.61 M)	4' MAX. (1.22 M)
3' MIN. (0.91 M)	3' MAX. (0.91 M)	8' MAX. (2.44 M)
4' MIN. (1.22 M)	4' MAX. (1.22 M)	10' MAX. (3.05 M)
V+H+H ₁ +H ₂ =30' MAX.(9.14 M)	H = 4' MAX.(1.22 M)	H+H ₁ +H ₂ =10' MAX.(3.05 M)

Figure 17.

Appliance Preparation

After determining which set of starting collars will be used (top or rear), follow flueing instructions accordingly.



WARNING: FAILURE TO REMOVE INSULATION IN THE SET OF COLLARS YOU ARE USING COULD CAUSE A FIRE.



WARNING: YOU MUST LEAVE THE INSULATION AND FLUE CAP IN PLACE IN THE SET OF COLLARS YOU ARE NOT USING.



WARNING: FIRE RISK ONCE APPLIANCE IS SETUP FOR TOP OR REAR FLUEING, IT CANNOT BE CHANGED AT A LATER TIME. IF FLUE CAP AND COMPONENTS PREVIOUSLY REMOVED ARE IMPROPERLY REINSTALLED, A FIRE MAY RESULT.

CAUTION

Sharp edges-Wear protective gloves and safety glasses during installation.

Top Flue



Figure 18. For top flue, remove the two screws holding the top heat shield in place. For rear flue, see next page.



WARNING: FIRE RISK DO NOT REMOVE HEAT SHIELD. ELEVATED HEADER TEMPERATURES MAY CAUSE A FIRE.

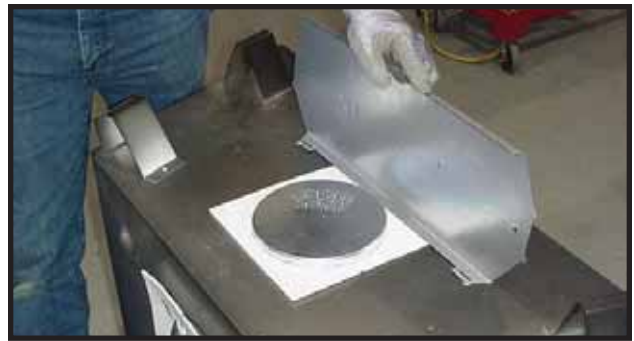

Figure 19. Rotate the top heat shield to the vertical position as shown above. The heat shield must remain in the vertical position.

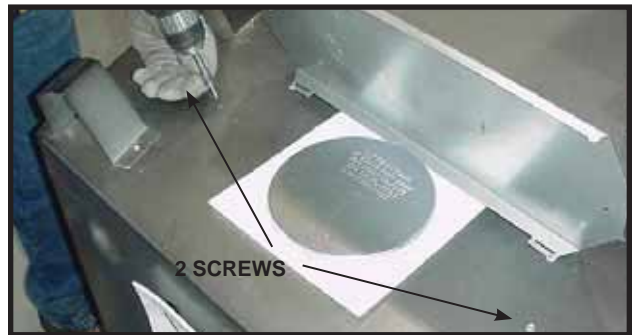

Figure 20. Replace the two screws as shown.



Figure 21. Remove the flue cap.



Figure 22. Remove the insulation basket and white insulation from the center flue pipe.



Figure 23. Remove the insulation from the outer flue pipe.



Figure 24. To attach the first section of flue pipe, make sure to use the fiberglass gasket to seal between the first vent component and the outer heater wrap. Use 2 self tapping screws to secure the gasket to the outer wrap.

Note: Once the flue cap has been removed, it cannot be reattached.

Rear Flue



Figure 25. Remove the insulation from the outer flue pipe.



Figure 26. Cut the metal retaining band and fold the sides out.



Figure 27. Fold the center parts of the retaining band out and use to remove the flue cap.



Figure 28. Discard the flue cap, remove and discard the insulation basket. Note: Once the flue cap has been removed it CANNOT be reattached.



Figure 29. Attach the first flue section (it will snap into place). Slide the insulation gasket onto the flue section, up against the appliance and over the tabs. Use two self-tapping screws to secure gasket to outer wrap.

Installing Flue Components

A. On the REAR of the heater

1. Attaching the First Flue Component to the Starting Collars:

To attach the first flue component to the starting collars on the rear of the heater:

- Make sure that the flue gasket supplied with the heater seals between the first flue component and the outer heater wrap.
- Slide the male end of the inner flue of the pipe section over the inner collar on the heater. At the same time, slide the outer flue over the outer collar on the heater. Push the flue section into the appliance collar until all the lances (see Figure 30) have snapped in place. Tug slightly on the flue to confirm that it has completely locked into place.

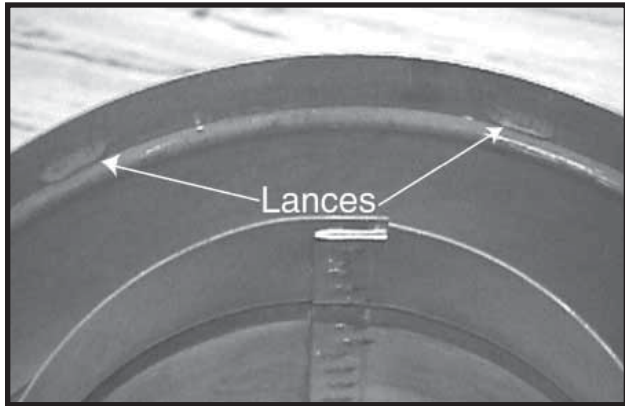



Figure 30.

- Any 90° elbow installed directly onto the rear flue of the heater **MUST BE** in a vertical position.



WARNING: ENSURE THAT THE HEATER GASKET SUPPLIED WITH THE HEATER SEALS BETWEEN THE FIRST FLUE COMPONENT AND THE OUTER HEATER WRAP.

⚠ WARNING	
	Fire Risk
	Exhaust Fumes Risk
	Impaired Performance of Appliance
	• Overlap pipe slip sections at least 38 mm.
	• Screws must not exceed one inch long.
	• Pipe may separate if not properly joined.

2. Assembling Flue Components

Insert the inner flue of section A into the flared inner flue of section B.

Start the outer flue of section A over the outer flue of section B (see Figure 31). **Note:** The end of the pipe sections with the lances/tabs on it will face towards the appliance.

Once both inner and outer flues are started, press section A onto section B firmly until all lances have snapped into place. Check to make sure they have snapped together (see Figure 32) and the seams are not aligned (see Figure 33). Tug slightly on section A to confirm it has completely locked into place.

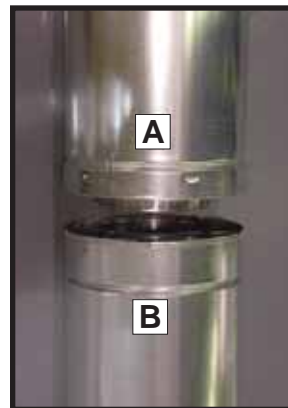

Figure 31.



Figure 32.

NOTE: Make sure that seams are **NOT** aligned to prevent unintentional disconnection.

For elbows that are changing the flue direction, two screws minimum should be put in the outer flue at the joint to prevent the elbow from rotating.

PROCEED TO STEP 4
(Install Support Brackets)

B. On the TOP of the heater

1. Attaching the First Flue Component to the Starting Collars:

To attach the first flue component to the starting collars on the top of the heater:

- Lock the flue components into place by sliding the concentric pipe sections into the heater collar or previously installed component end.

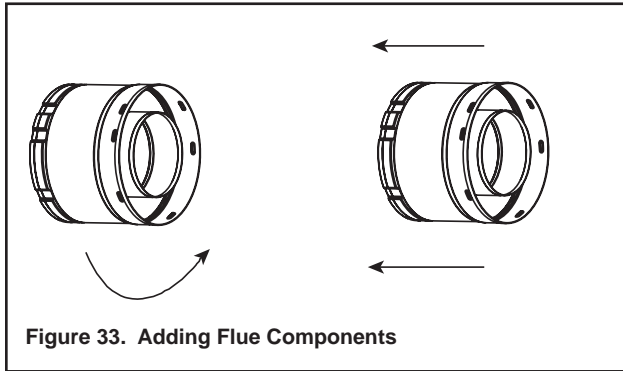

Figure 33. Adding Flue Components

- Align the seam of the pipe and seam of the collar to allow engagement. Rotate the flue to lock into place. Use this procedure for all the components. See Figure 33.
- Slide the gasket over the first flue section and place it flush to the heater. This will prevent cold air infiltration. High temperature caulk may be used to hold the gasket in place.

2. Continue Adding Flue Components

To continue adding flue components in accordance with the pre-planned flue system configuration:

- Ensure that each succeeding flue component is securely fitted and locked into the preceding component in the flue system.

For elbows that are changing the flue direction, two screws minimum should be put in the outer flue at the joint to prevent the elbow from rotating.

3. Assemble Slip Sections

- Slide the inner flue of the slip section into the inner flue of the pipe section and the outer flue of the slip section over the outer flue of the pipe section. See Figure 34.
- Slide together to the desired length.

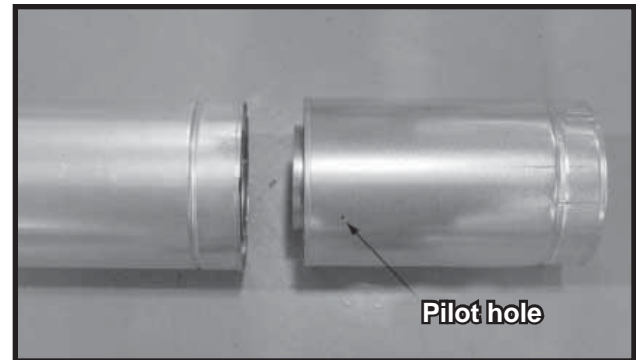

Figure 34. Slip Section Pilot Holes

- Maintain a 38 mm overlap between the slip section and the pipe section.
- Secure the pipe and slip section with two screws no longer than 13 mm, using the pilot holes in the slip section. See Figure 35.

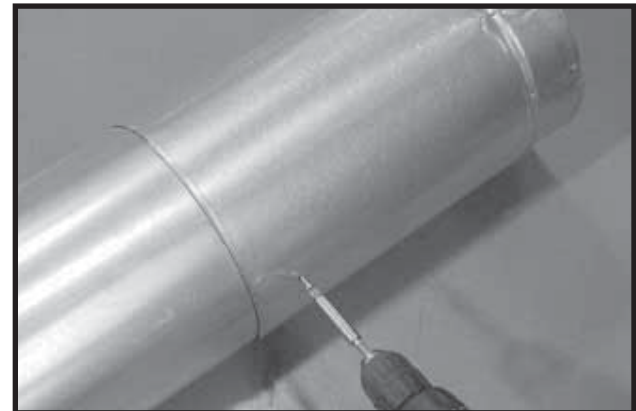

Figure 35. Screws into Slip Section

- Continue adding pipe as necessary following instructions in “Assembling Pipe Sections.”

NOTICE: If slip section is too long, the inner and outer flues of the slip section can be cut to the desired length.

4. Install Support Brackets

For Horizontal Runs - The flue system must be supported every 1.5 m of horizontal run by a horizontal pipe support.

To install support brackets for horizontal runs:

- Place the pipe supports around the flue pipe.
- Nail the pipe supports to the framing members.

For Vertical Runs

The flue system must be supported every 2.4 M above the heater flue outlet by wall brackets.

To install support brackets for vertical runs:

- Attach wall brackets to the flue pipe and secure the wall bracket to the framing members with nails or screws.

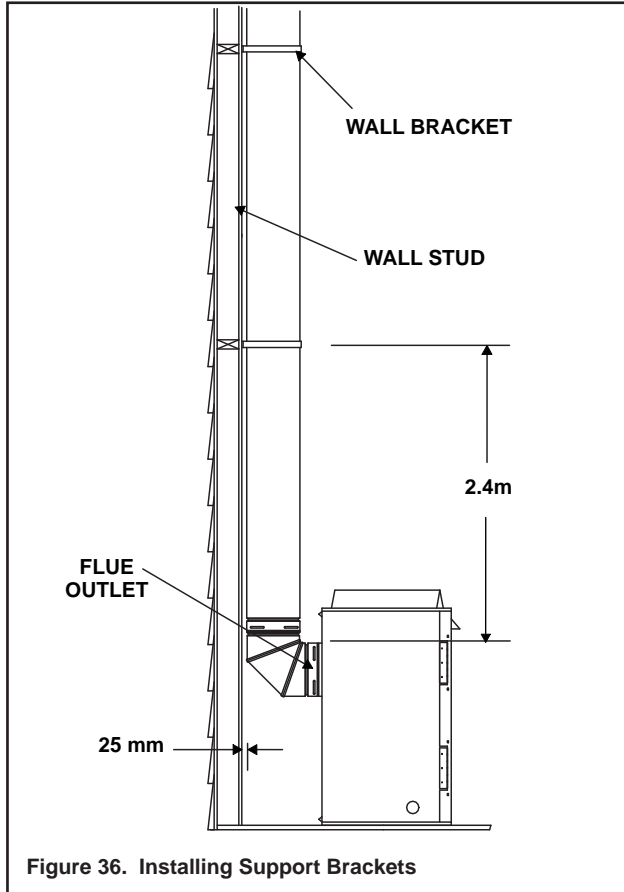

Figure 36. Installing Support Brackets

4. Install Firestops

For Horizontal Runs - Firestops are **REQUIRED** on both sides of a combustible wall through which the flue passes.

Frame a hole in a combustible wall for an interior wall shield firestop, whenever a wall is penetrated. Use same size framing materials as those used in the wall construction. The wall shield firestop maintains minimum clearances and prevents cold air infiltration. a wall shield firestop must be placed on each side of an interior wall. A minimum 38 mm overlap of attached heat shield must be maintained. See Figure 36.

Non-Combustible Wall Penetration

If the hole being penetrated is surrounded by non-combustible materials such as concrete, a hole with diameter 25.4 mm greater than the pipe is acceptable. Whenever a non-combustible wall is penetrated, the wall shield firestop is only required on one side and no heat shield is necessary.

For Vertical Runs - One firestop is **REQUIRED** at the hole in each ceiling through which the flue passes.

To install firestops for vertical runs that pass through ceilings:

- Position a plumb bob directly over the center of the vertical flue component.
- Mark the ceiling to establish the centerpoint of the flue.
- Drill a hole or drive a nail through this center point.
- Check the floor above for any obstructions, such as wiring or plumbing runs.
- Reposition the heater and flue system, if necessary, to accommodate the ceiling joists and/or obstructions.
- Cut a 254 mm X 254 mm hole through the ceiling when using DVP pipe, and a 229 mm x 229 mm hole when using SLP pipe. Use the firestop pipe opening as a guide.
- Frame the hole with framing lumber the same size as the ceiling joists.

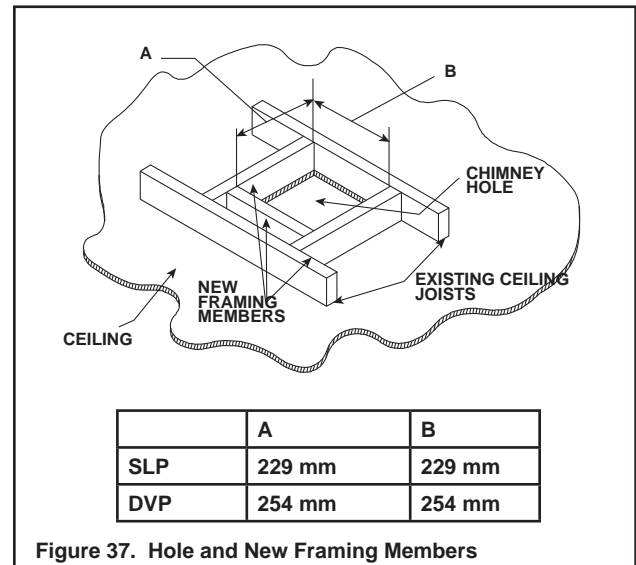

Figure 37. Hole and New Framing Members

If the area above the ceiling is **NOT** an attic, position and secure the ceiling firestop on the ceiling side of the previously cut and framed hole.

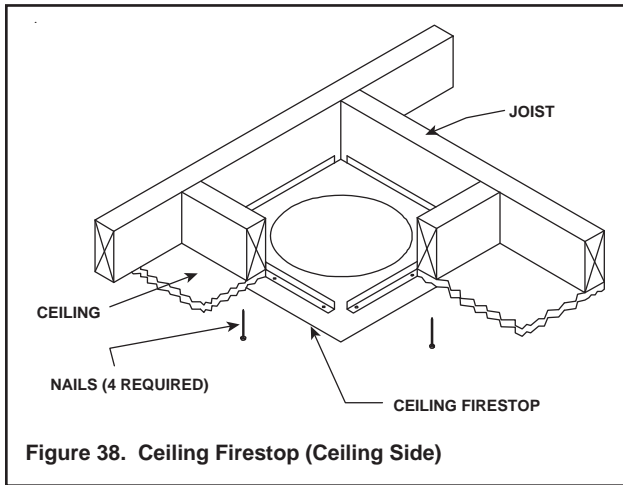

Figure 38. Ceiling Firestop (Ceiling Side)

If the area above the ceiling **IS** an attic, position and secure the firestop on top of the previously framed hole.

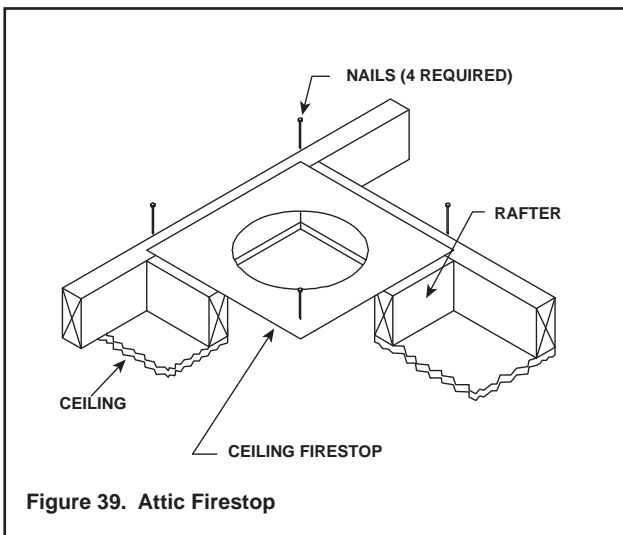

Figure 39. Attic Firestop

C. Flue Termination

For Horizontal Terminations using the DVP-TRAP

To attach and secure the termination to the last section of horizontal flue:

- The rear flue heat shield **MUST** be placed one inch above the top of the flue between the wall shield and the base of the termination cap.
- One section of the heat shield is attached to the wall shield. The other is attached to the termination cap in the same manner (see Figure 40).

- The heat shield sections will overlap to match the wall thickness (depth).
- If the wall thickness does not allow the required 1-1/2 inch heat shield overlap, an extended heat shield must be used. The extended heat shield will need to be cut to the thickness of the wall and be attached to the wall shield.
- The small leg in the shield rests on top of the flue to properly space it from the pipe section (see Figure 40).

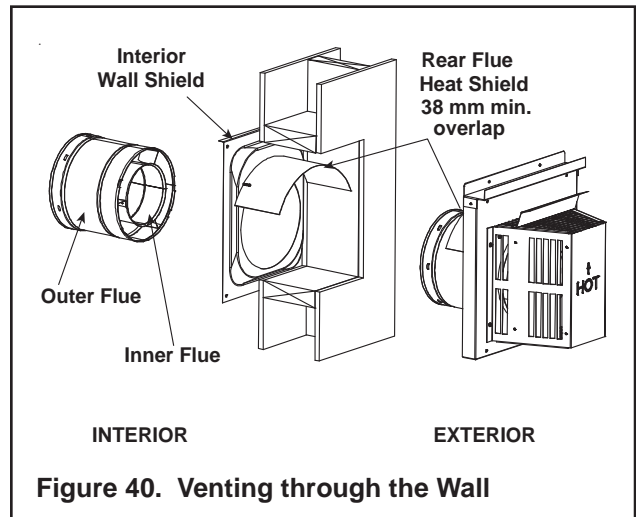

Figure 40. Venting through the Wall

- The termination kit should pass through the wall firestops from the exterior of the building.
- Adjust the termination cap to its final exterior position on the building and interlock the flue sections.



WARNING: THE TERMINATION CAP MUST BE POSITIONED SO THAT THE ARROW IS POINTING UP.

- Use a high-temperature sealant gasket to seal between the pipe and exterior firestop.

For Vertical Terminations - To locate the flue and install the flue sections:

- Locate and mark the flue centerpoint on the underside of the roof, and drive a nail through the centerpoint.
- Make the outline of the roof hole around the centerpoint nail.
- The size of the roof hole framing dimensions depend on the pitch of the roof. There **MUST BE** a 25 mm clearance from the vertical flue pipe to combustible materials.
- Mark the roof hole accordingly.
- Cover the opening of the installed flue pipes.
- Cut and frame the roof hole.
- Use framing lumber the same size as the roof rafters and install the frame securely. Flashing anchored to the frame must withstand heavy winds.
- Continue to install concentric flue sections up through the roof hole and up past the roof line until you reach the appropriate distance above the roof.

CAUTION: FOLLOW THE REQUIREMENTS OF THE AGA GAS INSTALLATION CODE FOR MINIMUM HEIGHT REQUIREMENTS ABOVE THE ROOF.

To seal the roof hole, and to divert rain and snow from the flue system:

- Attach a flashing to the roof using nails, and use a non-hardening mastic around the edges of the flashing base where it meets the roof.
- Attach a storm collar over the flashing joint to form a water-tight seal. Place non-hardening mastic around the joint, between the storm collar and the vertical pipe.
- Slide the termination cap over the end of the flue pipe and rotate the pipe clockwise 1/4 turn.

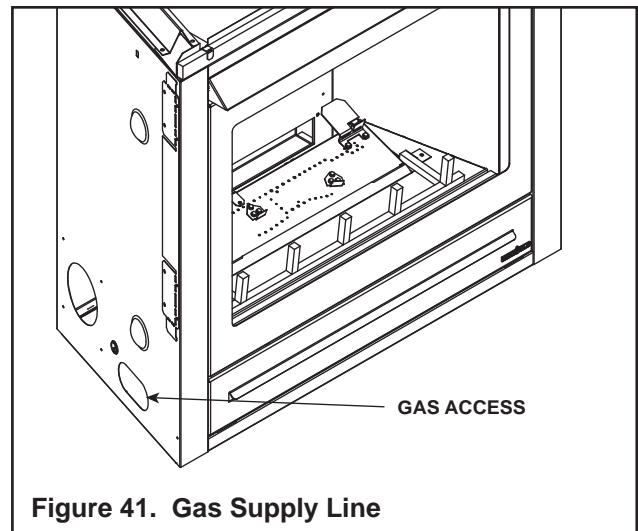

Figure 41. Gas Supply Line

1.3 CONNECTING THE GAS SUPPLY

The gas is introduced to the appliance on the left hand side (see Figure 41). After the gas pipe installation is complete, check carefully all gas connections for leaks with a commercially-available, non-corrosive leak check solution. Be sure to rinse off all leak check solution following testing. **DO NOT USE AN OPEN FLAME.** See Table 1 for pressure requirements.

NOTE: THE GAS SUPPLY LINE SHOULD BE PURGED OF ANY TRAPPED AIR PRIOR TO THE FIRST FIRING OF THE UNIT.

TABLE 1.

	Natural Gas	Propane Gas
Inlet Pressure	1.13 kPa	2.75 kPa
Outlet Pressure	.80 kPa	2.36 kPa
Max. Gas Consumption	21.0 mJ/h	19.8 mJ/h
Burner Injector	2.18 mm	1.32 mm

1.4 IGNITION SYSTEM WIRING

- This gas heater is equipped with an electronic ignition system which operates on a 6 volt system.
- This appliance requires 240 VAC to be wired to the factory installed junction box. Check factory installed power cord for damage before use.

CAUTION
Label all wires prior to disconnection when servicing controls. Wiring errors can cause improper and dangerous operation. Verify proper operation after servicing.

	WARNING
Shock hazard.	
<ul style="list-style-type: none"> • Replace damaged wire with type 105° C rated wire. • Wire must have high temperature insulation. 	

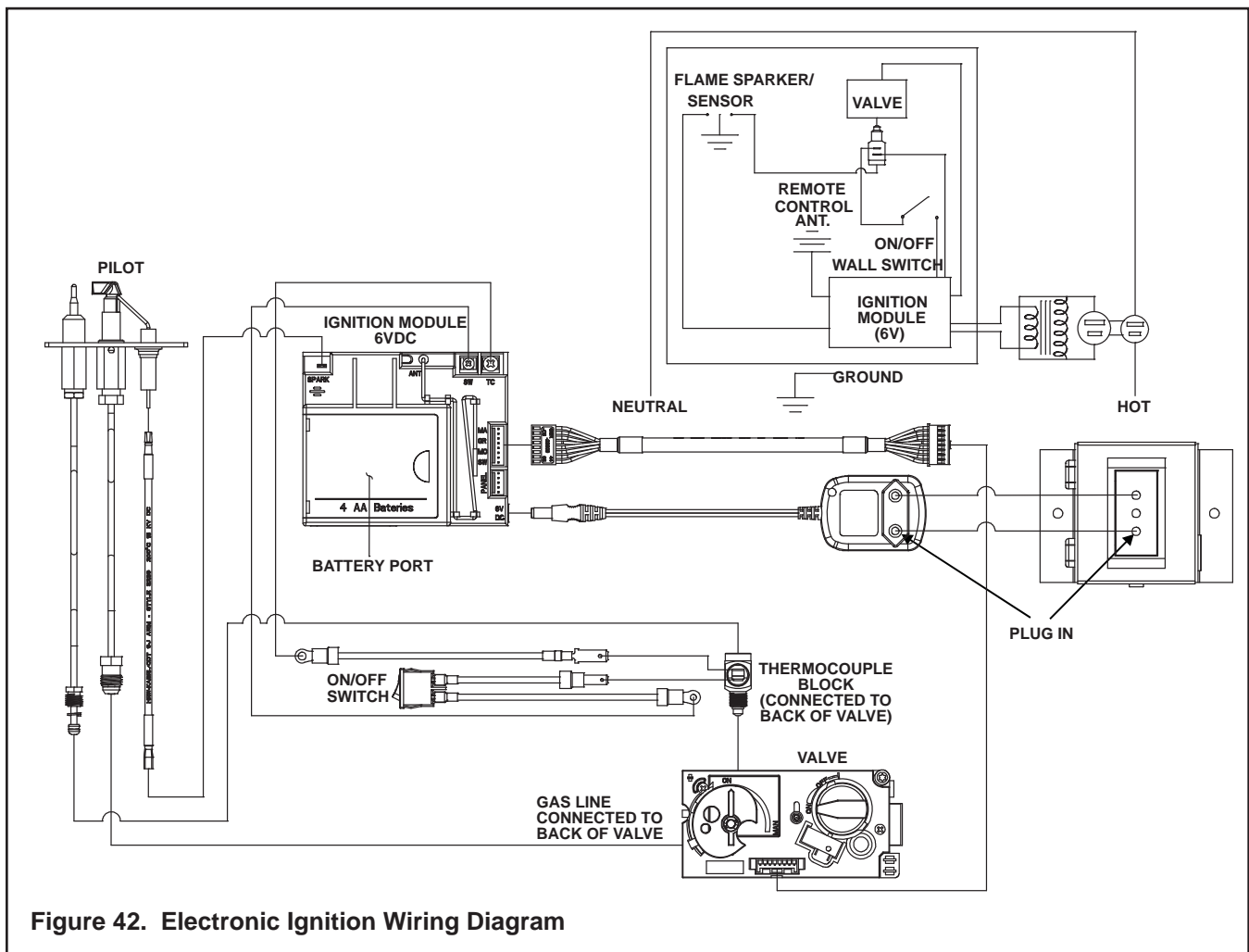

NOTE: IF ANY OF THE ORIGINAL WIRE AS SUPPLIED WITH THE APPLIANCE MUST BE REPLACED, IT MUST BE REPLACED WITH TYPE 105° C RATED WIRE.

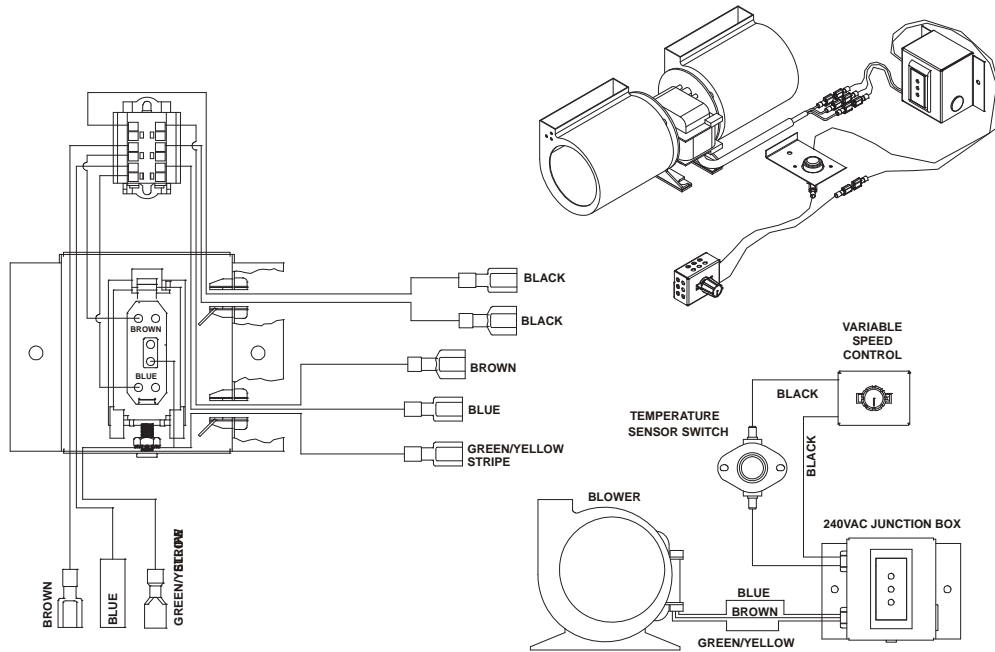

Figure 43.

1.5 BLOWER

These heaters have a factory installed Fan, Electrical Junction Box, Variable Speed Rheostat Control Switch and Temperature Sensor Switch for the fan. These components are located behind the lower door.

Use of the fan requires that the Junction Box (factory installed) be connected to 240 VAC service before permanently enclosing the heater. The access hole for connecting the service wires is found on the right exterior side of the unit. See Figure 44 for wire connection detail.

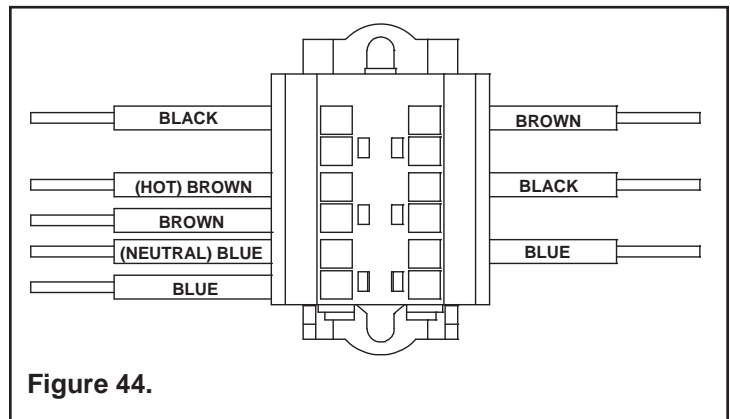
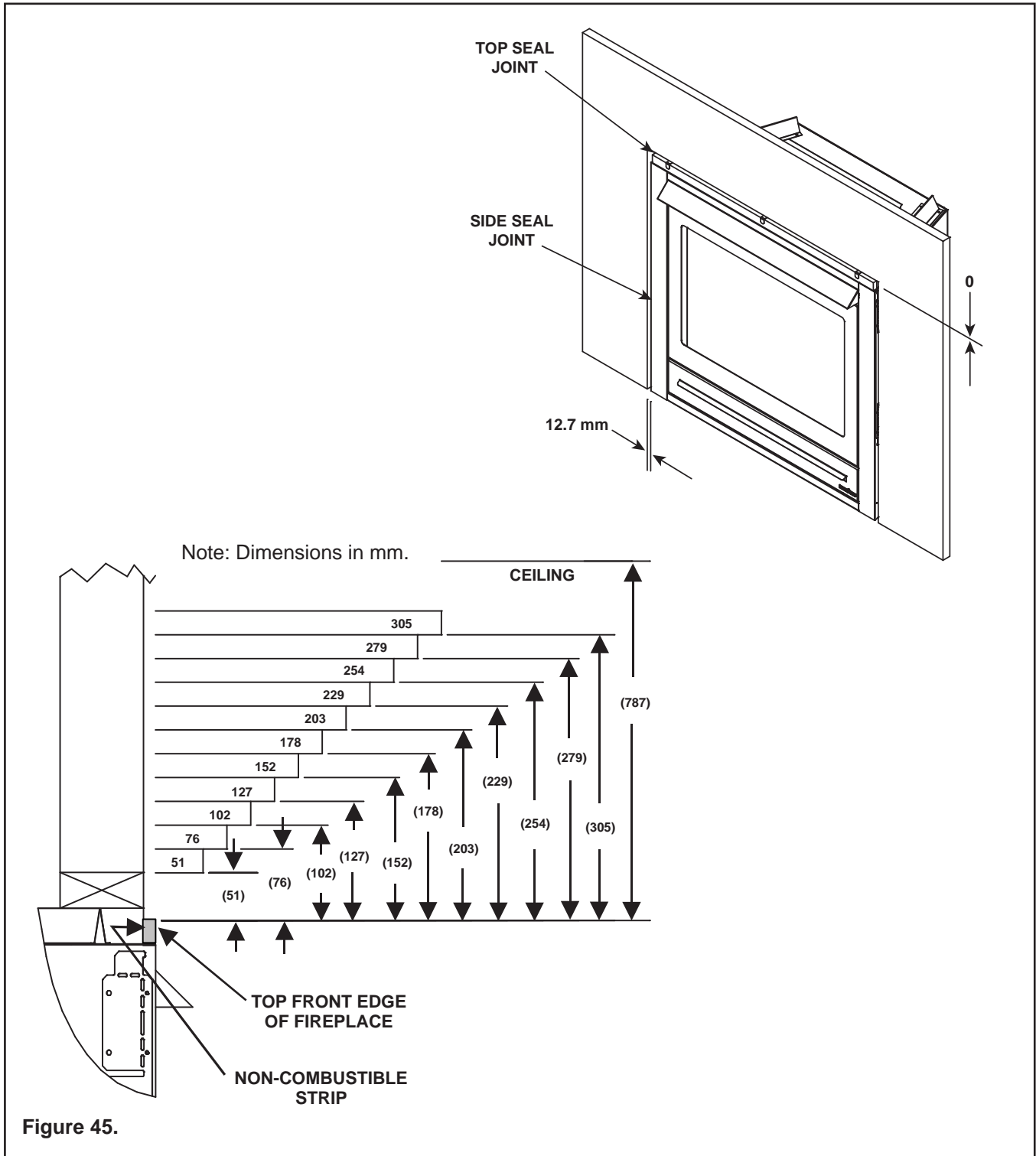

Figure 44.

1.6 FINISHING

The minimum clearance to combustibles are 0 from the sides, floor, back and top (these clearances are defined by the standoffs). The minimum distance to the perpendicular side wall extending past the appliance front is 51 mm. Clearance to a mantelpiece is shown in Figure 45.

IF JOINTS BETWEEN THE FINISHED WALLS AND THE HEATER SURROUND (TOP AND SIDES) ARE SEALED, 149° C. MINIMUM SEALANT MATERIAL MUST BE USED. THESE JOINTS ARE NOT REQUIRED TO BE SEALED. ONLY NON-COMBUSTIBLE MATERIAL (USING 149° C MINIMUM ADHESIVE, IF NEEDED) CAN BE APPLIED AS FACING TO THE HEATER SURROUND. SEE FIGURE 45.



Installing the Trim

Combustible materials may be brought up to the specified clearances on the side and top front edges of the heater, but **MUST NEVER** overlap onto the front face. The joints between the finished wall and the heater top and sides can only be sealed with a 149° C minimum sealant.



WARNING: WHEN FINISHING THE HEATER, NEVER OBSTRUCT OR MODIFY THE AIR INLET/OUTLET GRILLES IN ANY MANNER.

Install optional marble and brass trim surround kits as desired. Marble, brass, brick, tile, or other non-combustible materials can be used to cover up the gap between the sheet rock and the heater.

Do not obstruct or modify the air inlet/outlet grilles. When overlapping on both sides, leave enough space so that the bottom grille can be opened and the trim door removed.

1.7 INSTALLER TESTING

The space heater must be tested and be operating according to manufacturer's specifications prior to the installer leaving the site. Note: the tips of the flames should never hit the top of the firebox after the unit has warmed up. Please contact your dealer or a qualified service person to replace injector or adjust valve.

Upon completing the gas line connection, a small amount of air will be in the lines. When first lighting the pilot light, it will take a few minutes for the lines to purge themselves of this air. Once the purging is complete, the pilot and burner will light and operate as indicated in the Lighting Instructions.

Subsequent lightings of the appliance will not require such purging.

Follow the Safety Information and Lighting Instructions pages of this manual to light the appliance.

To obtain proper operation, it is imperative that the pilot and main burner flame characteristics are steady, not lifting or floating. Typically, the top 3/8-inch (10 mm) of the thermocouple should be engulfed in the pilot flame (see Figure 46).

Proper gas log positioning is shown in Section 1.8.

Follow Section 3.5 TROUBLESHOOTING for adjusting the appliance to operate properly.

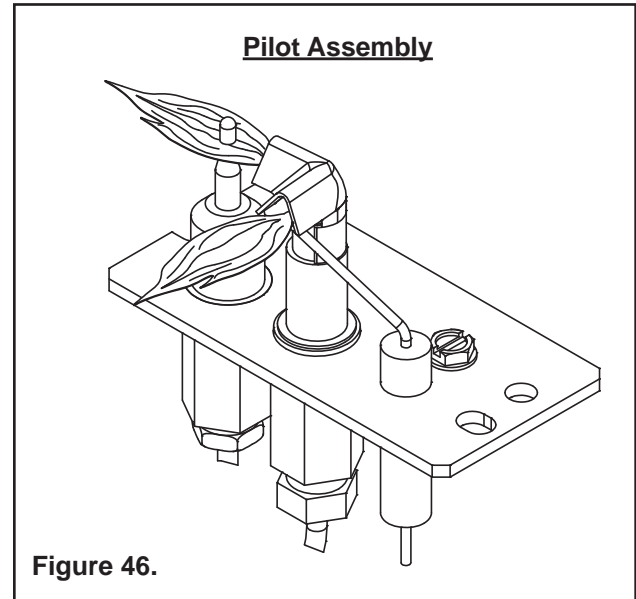
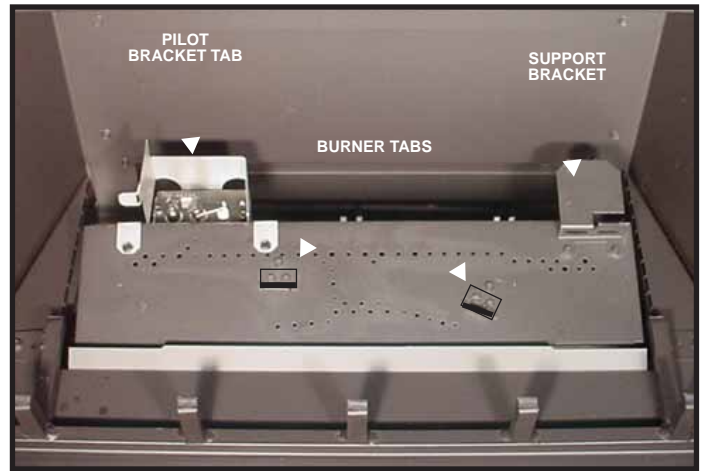

Figure 46.

1.8 LOG PLACEMENT INSTRUCTIONS

Log Set Assembly: LOGS-350CE-D



Carefully remove the logs from the packaging. **CAUTION:** Logs are fragile!

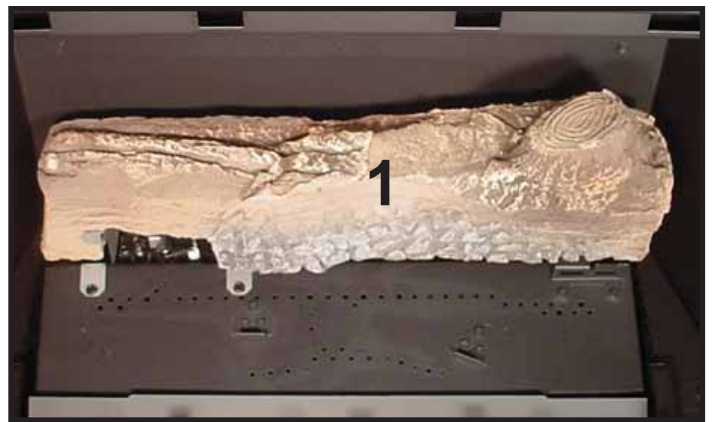

LOG #1 (SRV327-701): Place log #1 at the rear of the unit, with the left edge behind the tab on the pilot bracket. The right side sits behind the tab on the support bracket.



LOG #2 (SRV2033-701): Locate the bottom groove of log #2 over the left most grate bar and align over the burner by placing the log slot over the burner tab as shown.



LOG #3 (SRV705-703): Rest log #3 against the right front grate corner and place its slot over the right burner tab.



LOG #4 (SRV530-716): Place the left end of log #4 in the groove on log #2 and the right end on log #1 as shown.



LOG #5 (SRV438-724): Locate the top of log #5 onto log #1 and log #3, and place the bottom on the right side of the fourth log grate.



LOG #6 (SRV540-704): Place log #6 against the second and third grate bars.

If sooting occurs, the logs might need to be repositioned slightly to avoid excessive flame impingement.

2.0 OPERATING INSTRUCTIONS

This appliance is a balanced flue heater and is designed to operate with all combustion air being siphoned from the outside of the building and all exhaust gases expelled to the outside of the building.



WARNING: THIS UNIT IS NOT FOR USE WITH SOLID FUEL.

The control system for this model is an electronic system which includes a gas control valve, pilot, thermocouple, ignitor and electronic ignition module. The controls are located in the lower compartment behind the lower door, and access is gained by lifting the door up. See Figure 1.



WARNING: DO NOT CONNECT 240 VAC TO THE GAS CONTROL VALVE OR CONTROL WIRING SYSTEM OF THIS UNIT.

When lit for the first time, the appliance will emit a slight odor for an hour or two. This is due to paint and lubricants used in the manufacturing process. Additionally, for the first few minutes after each lighting, vapor may condense and fog the glass and the flames may be blue. After a few minutes this moisture will disappear and within 15-30 minutes the flames should become yellow.

The heater may produce a noise, caused from metal expansion and contraction as it heats up and cools down. This noise is similar to one that a furnace or heat duct may produce and does not affect the operation or longevity of the heater.

OPERATING CAUTIONS

- This appliance may exhibit a slight carbon deposition.
- Do not place articles on or against this appliance.
- Do not use or store flammable materials near this appliance.
- Do not spray aerosols in the vicinity of this appliance while it is in operation.
- The DRESS GUARD IS fitted to this appliance to reduce the risk of fire or injury from burns and no part of it should be permanently removed. For protection of young children or the infirm, a secondary guard is required.
- The glass door assembly must be in place and sealed and the fixed mesh DRESS GUARD must be in place on the heater before the unit can be placed into safe operation.
- Do not use this appliance if any part has been under water. Immediately call a qualified service technician to inspect the unit and to replace any part of the control system and any gas control which has been underwater.
- Do not operate this appliance with the glass door removed, cracked, or broken. Replacement of the glass door should be done by a licensed or qualified person. Do not strike or slam the glass door.
- The glass door assembly shall only be replaced as a complete unit as supplied by the gas heater manufacturer. No substitute materials may be used.

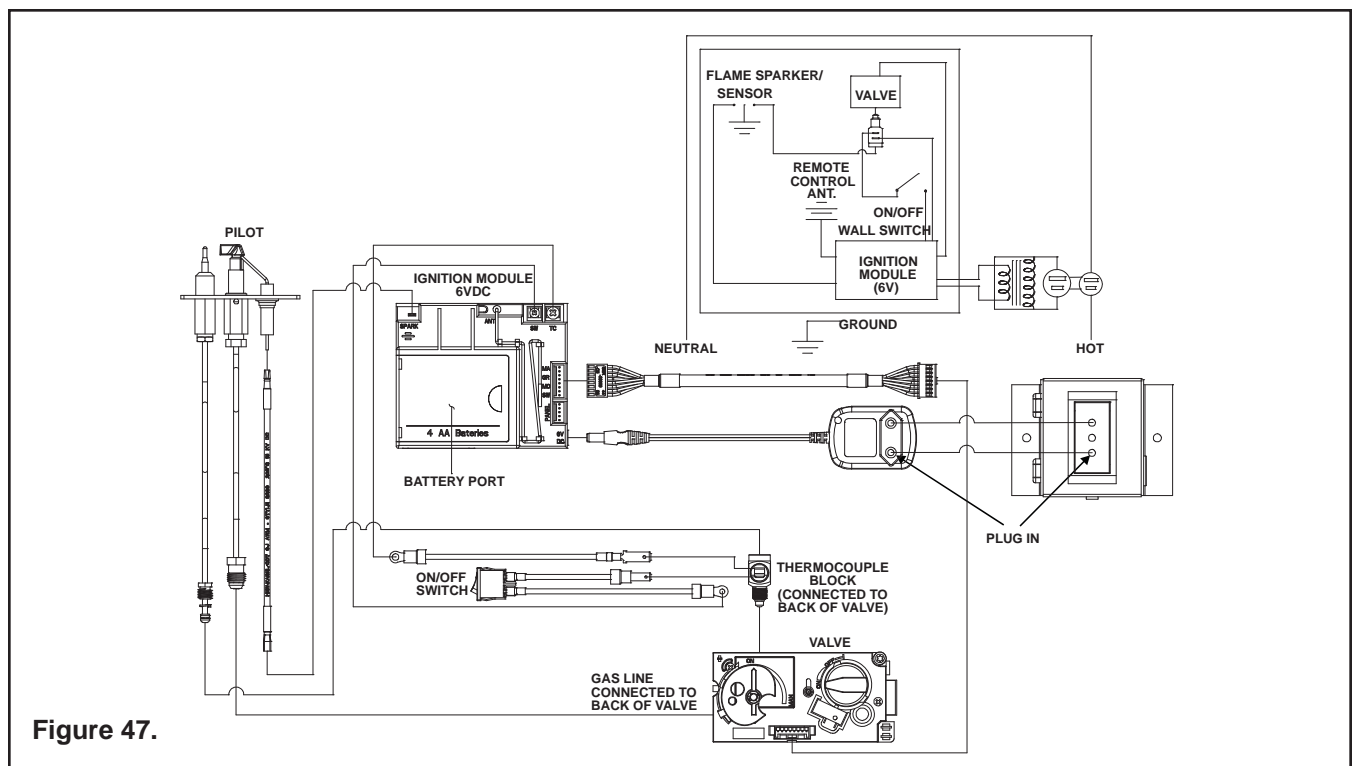

Figure 47.

A. SAFETY & LIGHTING INFORMATION

Follow **SAFETY INFORMATION** and **LIGHTING INSTRUCTIONS** to light the appliance.

By design, the flame pattern will not be identical from unit to unit. Additionally, flame pattern may vary depending on installation type and weather conditions.

NOTE: THE TIPS OF THE FLAMES SHOULD NEVER HIT THE TOP OF THE FIREBOX.

These gas models have remote control valve which allow you to increase or decrease the height of the main burner flames. Push the ▲ button to increase the flame height and the ▼ button to decrease the flame height.

FOR YOUR SAFETY READ BEFORE LIGHTING

WARNING: If you do not follow these instructions exactly, a fire or explosion may result causing property damage, personal injury or loss of life.

- A.** This heater is equipped with an electronic pilot ignition device which automatically lights the burner. Do not try to light the burner by hand.
- B. BEFORE LIGHTING**, smell all around the heater area for gas. Be sure to smell next to the floor because some gas is heavier than air and will settle on the floor.
- WHAT TO DO IF YOU SMELL GAS**
- Do not try to light any appliance.
 - Do not touch any electric switch; do not use any phone in your building.
 - Immediately call your gas supplier from a neighbor's phone. Follow the gas supplier's instructions.
 - If you cannot reach your gas supplier, call the fire department.
 - C.** Do not use this heater if any part has been under water. Immediately call a qualified service technician to inspect the heater and to replace any part of the control system and any gas control which has been under water.

WARNING:

DO NOT CONNECT 240 VAC TO THE CONTROL VALVE.

Improper installation, adjustment, alteration, service or maintenance can cause injury or property damage. Refer to the owner's information manual provided with this heater.

This heater needs fresh air for safe operation and must be installed so there are provisions for adequate combustion and ventilation air.

If not installed, operated, and maintained in accordance with the manufacturer's instructions, this product could expose you to substances in fuel or fuel combustion.

Keep burner and control compartment clean. See installation and operating instructions accompanying heater.

CAUTION:

Hot while in operation. Do not touch. Keep children, clothing, furniture, gasoline and other liquids having flammable vapors away.

Do not operate the heater with panel(s) removed, cracked or broken. Replacement of the panel (s) should be done by a licensed or qualified service person.

NOT FOR USE WITH SOLID FUEL

For use with natural, propane and butane gases.

LIGHTING INSTRUCTIONS

1. This heater is equipped with an ignition device which automatically lights the burner. Do not try to light the burner by hand.

GAS VALVE

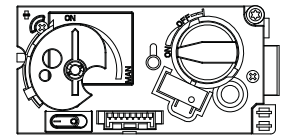

2. Wait five (5) minutes to clear out any gas. Then smell for gas, including near the floor. If you smell gas, STOP! Follow "B" in the Safety Information located on the left side of this label. If you don't smell gas, go to next step.
3. To light the burner, simultaneously press the star ✱ and up ▲ arrow buttons on the remote control until a short acoustic signal confirms the start sequence has begun.
4. If the heater will not operate, check the batteries then follow the instructions "To Turn Off Gas to Heater" and call your service technician or gas supplier.

TO TURN OFF GAS TO HEATER

1. Push the 'OFF' button on remote.
2. Remove batteries from receiver.

2.2 POWER OUTAGE

In the event of a power interruption during operation, either push the OFF button on the remote control or open access door and push the switch to OFF (as shown in Figure 48) to shut off manually. The switch must be returned to the ON position prior to operation once power is restored.

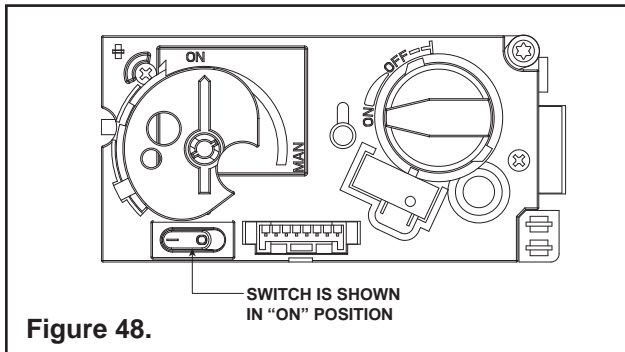

2.3 FAN OPERATION

The accessory fan is wired in series with a speed control switch and a temperature sensor switch. Set the speed control to an "ON" position and light the heater. The temperature sensor switch will automatically start the fan when the switch warms up—and stop the fan when it cools down. You can manually stop the fan by turning the speed control switch to "OFF". See Figure 43 for fan wiring diagram.

3.0 SERVICING AND MAINTENANCE

- A. **HEATER SERVICING:** Frequency of heater servicing will depend upon use and type of installation.
- B. **IMPORTANT:** TURN OFF GAS AND ELECTRICAL POWER BEFORE SERVICING APPLIANCE. IT IS RECOMMENDED THAT A COMPETENT SERVICE TECHNICIAN PERFORM SERVICE CHECK-UPS AT THE BEGINNING OF EACH HEATING SEASON.
- C. The appliance and flue system should be inspected before initial use and at least annually by a qualified field service person.
- D. Inspect the external flue cap on a regular basis to make sure that no debris is interfering with the air flow.
- E. Keep the control compartment, logs, and burner area surround the logs clean by vacuuming or brushing at least twice a year.

CAUTION: THE LOGS GET VERY HOT - HANDLE ONLY WHEN COOL.



WARNING: DO NOT USE ABRASIVE CLEANERS ON THE GLASS DOOR ASSEMBLY. DO NOT ATTEMPT TO CLEAN THE GLASS DOOR WHEN IT IS HOT.

- F. The glass door should be cleaned using a household glass cleaner. **DO NOT** handle or attempt to clean the glass when it is **HOT**.
- G. Visually inspect the flexible power supply cord; if damaged, contact the service agent for a special replacement cord assembly.
- H. In order to properly clean the burner and pilot assembly, turn off the gas to the unit and remove the logs exposing the burner and pilot assembly. Clean all foreign materials from top of burner. Check to make sure that the burner orifice is clean.

Visually inspect the pilot periodically. Brush or blow away any dust or linen accumulations. If the pilot orifice is plugged, disassembly may be required to remove any foreign materials from the orifice or tubing. When the appliance is put back in service, check burner flame patterns. Flames should be steady, not floating.

To obtain proper operation, it is imperative that the pilot and main burner flame characteristics are steady, not lifting or floating. Typically, the top 3/8-inch (10m) of the thermocouple should be engulfed in the pilot flame (Figure 49).

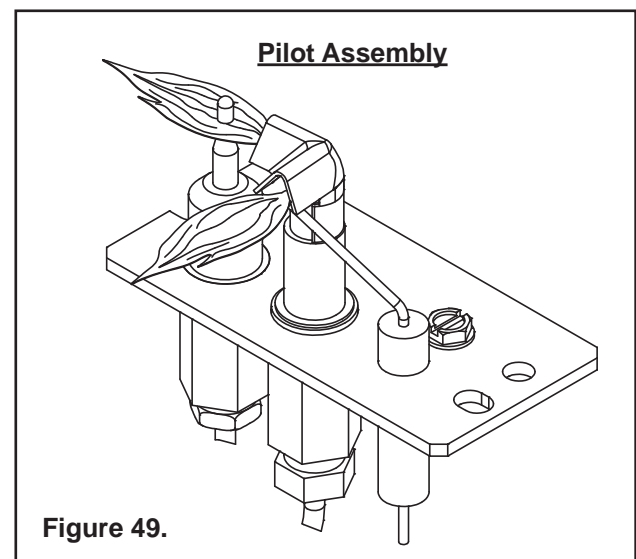

3.1 REMOVAL OF COVERS FOR SERVICING

A. Control Compartment Door

- Rotate the lower door down to access the gas controls.

B. Dress Guard and Glass Door

- Lift the front dress guard up and out away from the appliance side surrounds. Replace the dress guard when servicing is complete.
- Release the four glass clips around the glass door. Carefully lift the glass up and out away from the appliance (see Figure 50).

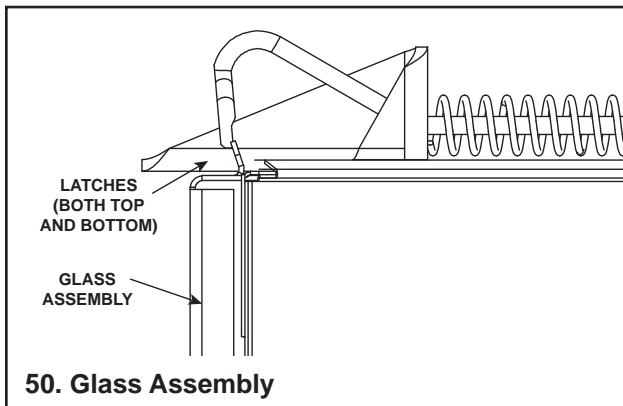

3.2 REMOVAL OF COMPONENTS FOR SERVICE

1. BURNER

- Remove the screws holding the log grate. Carefully lift up and remove the log set, log grate, and metal base pan.
- Unscrew the brackets at both ends of the burner and the retaining screws at the pilot bracket (see Figure 51). Slide the burner towards the right away from the burner orifice.

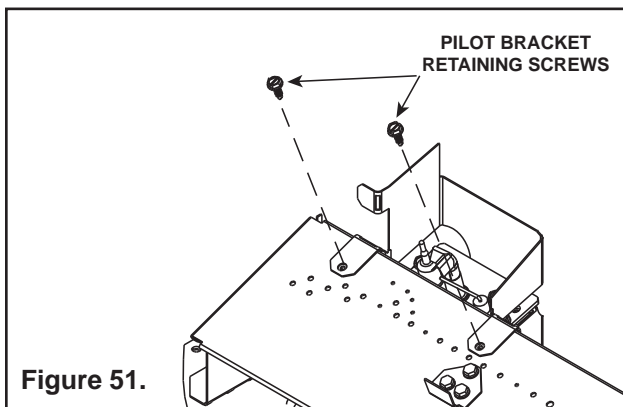

CAUTION: ALL SCREWS WHICH WERE REMOVED MUST BE REPLACED.

2. PILOT ASSEMBLY/IGNITION SYSTEM

- Remove the log set, log grate, metal base pan and burner.
- Disconnect the gas supply tube from the underside of the gas valve and the thermocouple from the interruptor block.
- Disconnect and remove the pilot assembly from the bracket.

NOTE: When removing the pilot assembly, carefully pull the electrode wire, detach from the assembly and leave in place for reconnection.

3.3 PARTS REPLACEMENT

1. FAN/SWITCHES

- Disconnect the fan wires from the junction box wires by pulling the male and female connectors apart and slide the fan out the front of the lower controls compartment.
- Disconnect the wires from the fan speed control switch, pull off the knob, and remove the nut holding the speed control to the bracket.
- Disconnect the wires from the fan temperature sensor switch and remove the nut holding the switch bracket onto the side of the firebox.

2. GLASS PANEL

- To replace the glass door, place the bottom edge on top of the bottom mounting brackets. Push glass against unit and latch the two fasteners at the top of the glass door and the two fasteners at the bottom (see Figure 50).

3.4 ADJUSTMENTS AND REPLACEMENT PARTS

Adjustments and replacement parts for this appliance should only be done by a qualified service person. A wiring diagram for the appliance is shown in **SECTION 2.0 OPERATING INSTRUCTIONS**. A replacement part table is shown in **SECTION 4.0** of this manual.

3.5 MAINTENANCE TASKS

Inspect	Maintenance Tasks
Doors	<ol style="list-style-type: none"> 1. Inspect for scratches, dents or other damage and repair as necessary. 2. Verify no obstructions to airflow. 3. Verify maintenance of proper clearance to combustible household objects.
Gasket Seal, Glass Assembly and Glass	<ol style="list-style-type: none"> 1. Inspect gasket seal and its condition. 2. Inspect glass panels for scratches and nicks that can lead to breakage when exposed to heat. 3. Confirm there is no damage to glass or glass frame. Replace as necessary. 4. Verify that latches engage properly, clip studs are not stripped, and glass attachment components are intact and operating properly. Replace as necessary. 5. Clean glass. Replace glass assembly if severely coated with silicate deposits that cannot be removed.
Valve Compartment and Firebox Top	<ol style="list-style-type: none"> 1. Vacuum and wipe out dust, cobwebs, debris or pet hair. Use caution when cleaning these areas. Screw tips that have penetrated the sheet metal are sharp and should be avoided. 2. Remove any foreign objects. 3. Verify unobstructed air circulation.
Logs	<ol style="list-style-type: none"> 1. Inspect for broken, damaged, or missing logs. Replace as necessary. 2. Verify correct log placement and no flame impingement causing sooting. Correct as necessary.
Firebox	<ol style="list-style-type: none"> 1. Inspect for paint condition, warpage, corrosion or perforation. Sand and repaint as necessary.
Burner Ignition and Operation	<ol style="list-style-type: none"> 1. Verify burner is properly secured and aligned with pilot or igniter. 2. Clean off burner top, inspect for plugged ports, corrosion or deterioration. Replace burner if necessary. 3. Replace ember materials with new dime-size and shape pieces. Do not block ports or obstruct lighting paths. 4. Check for smooth lighting and ignition carryover to all ports. Verify there is no ignition delay. 5. Inspect for lifting or other flame problems. 6. Inspect orifice for soot, dirt or corrosion. 7. Verify manifold and inlet pressures. Adjust regulator as required. 8. Inspect pilot flame strength. Clean or replace orifice as necessary. 9. Inspect thermocouple or IPI sensor rod for soot, corrosion and deterioration. Clean with emery cloth or replace as required.
Flueing	<ol style="list-style-type: none"> 1. Inspect venting for blockage or obstruction such as bird nests, leaves, etc. 2. Confirm that termination cap remains clear and unobstructed by plants, etc. 3. Verify that termination cap clearance to subsequent construction (building additions, decks, fences or sheds) has been maintained. 4. Inspect for corrosion or separation. 5. Verify weather stripping, sealing and flashing remains intact.
Remote controls	<ol style="list-style-type: none"> 1. Verify operation of remote. 2. Replace batteries in remote transmitters and battery-powered receivers.

3.6 TROUBLESHOOTING

SL-350TRSI-AUE

With proper installation and maintenance, your new Gas Heater should provide years of trouble-free service. If you do experience a problem, refer to the Trouble Shooting Guide below. This guide will assist a qualified service person in the diagnosis of problems and the corrective action to be taken.

Electronic Ignition System

Symptom	Possible Causes	Corrective Actions
1. No transmission, motor does not turn.	a. Receiver must learn new code.	Press and hold the receiver's reset button until you hear 2 acoustic signals. After the second longer acoustic signal, release the reset button and within the subsequent 20 seconds, press the down arrow on the remote handset until you hear an additional long acoustic signal confirming the new code is set.
2. No ignition. No tone.	a. Receiver	Replace receiver and reprogram code.
3. No ignition; one 5 seconds continuous tone (7 shorts beeps might be heard prior to the 5 seconds tone).	a. ON/OFF switch is in OFF position.	Push switch to ON position.
	b. Loose wire.	Secure wire.
	c. Receiver.	Replace receiver and reprogram.
	d. Bent pins on 8 wire connector.	Straighten pins on 8 wire connector.
	e. Valve.	Replace valve.
4. No pilot flame and control continues to spark.	a. Air in the pilot supply line.	Purge the line or start ignition several times.
	b. Thermocouple circuit wired incorrectly.	Check polarity of the thermocouple wires.
	c. No spark at pilot burner	Check spark gap, check wiring connection. Check for spark in location along cable.
	d. Valve.	Replace valve. Do not over tighten.
	e. Over tightened thermocouple interrupter.	Replace valve and thermocouple interrupter.
	f. Receiver.	Replace receiver and reprogram code.
5. Pilot is lit and control continues to spark. Valve shuts off after 10 to 30 seconds. Valve operates manually.	a. Receiver.	Replace receiver and reprogram code.
6. Pilot is lit, sparking stops if a flame is present. Valve shuts off after 10 to 60 seconds. Valve does not work manually.	a. Thermocouple.	Replace thermocouple.
	b. Low inlet pressure to valve.	Confirm sufficient inlet pressure to the valve. Adjust or replace inlet regulator if necessary.
	c. Valve.	Replace valve and the thermocouple interrupter.
7. 3 short beeps while the motor turns.	a. Batteries are low.	Replace batteries - quality alkaline recommended. WARNING: Creating an electrical short between the batteries/battery box and metal parts of the appliance may render the receiver inoperable.
8. Pilot flame lights but there is no main gas flow.	a. Manual override knob (if equipped) is in MAN position.	Turn Manual override knob to ON position.
	b. Valve turned don to pilot flow.	Turn flame to high fire by pressing up button on remote handset.
	c. Low inlet pressure to valve.	Confirm sufficient inlet pressure to the valve. Adjust or replace inlet regulator if necessary.
9. Pilot sparks, but pilot will not light.	a. Correct gas supply.	Verify that incoming gas line ball valve is "open". Verify that inlet pressure reading is within acceptable limits, inlet pressure must not exceed 50 mbar.
	b. Ignitor gap is too large.	Verify that spark gap from ignitor to pilot hood is .43 cm.
	c. Module is not grounded.	Verify module is securely grounded to metal chassis of heater.
10. Glass soots.	a. Flame impingement on logs.	Adjust the log set so that the flame does not impinge on it.
	b. Improper venturi setting.	Adjust the air shutter at the base of the burner.
	c. Debris around venturi.	Inspect the opening at the base of the burner. It is imperative that NO material be placed in this opening.
11. Flame burns blue and lifts off burner.	a. Insufficient oxygen being supplied.	<ol style="list-style-type: none"> 1. Check to make sure flue cap is installed properly and free of debris. Make sure that flue system points are tight and have no leaks. 2. Check to make sure that no material has been placed in the opening at the burner base or in the area of the air holes in the center of the base pan beneath the burner. 3. Be sure glass is tightened properly on unit, particularly on top corners.

4.0 REPLACEMENT PARTS



No one builds a better fire

Service Parts

Service Parts Diagram

SL-350TRSI-AUE

Beginning Manufacturing Date: June 2006
Ending Manufacturing Date: _____

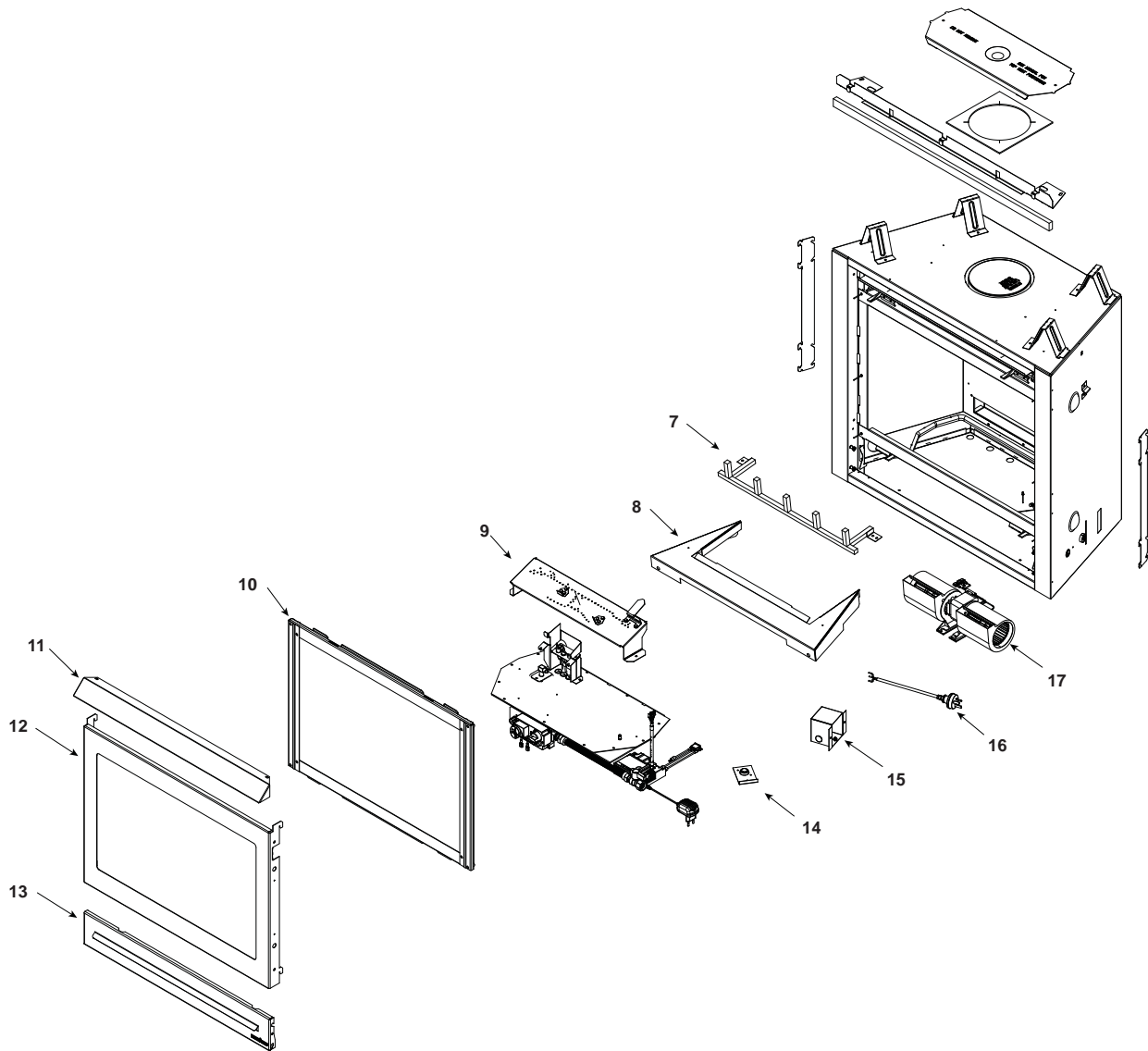

Log Set Assembly

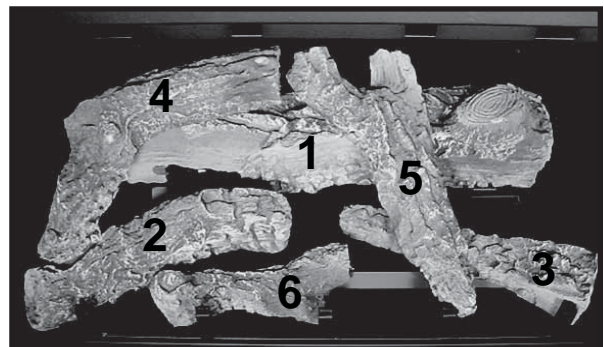

Part number list on following page

IMPORTANT: THIS IS DATED INFORMATION. When requesting service or replacement parts for your appliance please provide model number and serial number. All parts listed in this manual may be ordered from an authorized dealer.

ITEM	DESCRIPTION	COMMENTS	PART NUMBER
	Log Set Assembly		LOGS-350CE-D
1	Log #1		SRV327-701
2	Log #2		SRV2033-701
3	Log #3		SRV705-703
4	Log #4		SRV530-716
5	Log #5		SRV438-724
6	Log #6		SRV540-704
7	Grate		2033-013
8	Base Pan		2033-105
9	Burner Assembly N		2089-010
	Burner Assembly P		2089-012
10	Glass Door Assembly	Pre 0021061383	GLA-350TRS
		Post 0021061383	GLA-3504TRS
11	Hood		SRV540-174
12	Dress Guard		2033-020
13	Lower Door		2033-021
14	Switch Sensor		046-018A
15	Junction Box, 240V		2078-027
16	Power Cord, 240V		546-251A
17	Blower Assembly 240V		GFK-240V
	Control Wire		2098-148
	Exhaust Restrictor		2089-299
	Gasket Assembly Includes: Burner Neck, Shutter Bracket, Vent, Seal Cap, Valve Plate and Air Passage Gaskets.		2113-080
→	Glass Latch Assembly	Qty 4 req	33858
	Heat Shield (Control Module)		2078-121
	Interior Top Heat Shield		2089-109
	Mesh Assembly		540-301A
	Mineral Wool		050-721
	Multi Function Remote Control		REM-DLX-CE
	Wire Harness 20 in.		107-558A
	Conversion Kits		
	Propane/Butane to Natural		PB2N-350I-AUE
	Propane to Butane		P2B-350I-AUE
	Conversion Kit Natural to Propane/Butane		N2PB-350I-AUE
	Pilot Orifice N .0181		2098-518
	Pilot Orifice B .0121		2098-512

Additional service parts appear on following page.

Valve Assembly

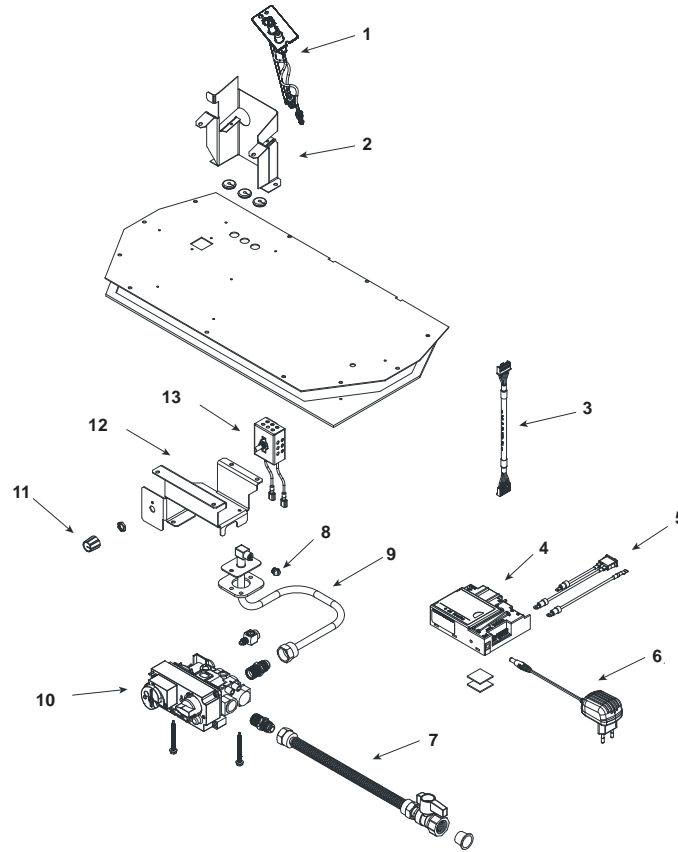

IMPORTANT: THIS IS DATED INFORMATION. When requesting service or replacement parts for your appliance please provide model number and serial number. All parts listed in this manual may be ordered from an authorized dealer.

ITEM	DESCRIPTION	COMMENTS	PART NUMBER
1	Pilot Assembly N		2098-050
	Pilot Assembly P		2098-051
2	Pilot Bracket		2089-104
3	Control Cable		2098-143
4	Module, Maxitrol		2098-142
5	Switch Assembly		2098-145
6	6 Volt Transformer		2098-144
7	18 inch Flex		2098-320A
8	Orifice N (#44C)		582-844
	Orifice P (#55C)		582-855
	Orifice B (#56C)		582-856
9	18 in Flex Tube Assembly		383-302A
10	Valve N		2098-134
	Valve P		2098-135
11	Rheostat Knob		100-512
12	Valve Bracket		2089-120
13	Rheostat		491-510A

Limited Lifetime Warranty

Hearth & Home Technologies Inc. LIMITED LIFETIME WARRANTY

Hearth & Home Technologies Inc., on behalf of its hearth brands ("HHT"), extends the following warranty for HHT gas, wood, pellet, coal and electric hearth appliances that are purchased from an HHT authorized dealer.

WARRANTY COVERAGE:

HHT warrants to the original owner of the HHT appliance at the site of installation, and to any transferee taking ownership of the appliance at the site of installation within two years following the date of original purchase, that the HHT appliance will be free from defects in materials and workmanship at the time of manufacture. After installation, if covered components manufactured by HHT are found to be defective in materials or workmanship during the applicable warranty period, HHT will, at its option, repair or replace the covered components. HHT, at its own discretion, may fully discharge all of its obligations under such warranties by replacing the product itself or refunding the verified purchase price of the product itself. The maximum amount recoverable under this warranty is limited to the purchase price of the product. This warranty is subject to conditions, exclusions and limitations as described below.

WARRANTY PERIOD:

Warranty coverage begins on the date of installation. In the case of new home construction, warranty coverage begins on the date of first occupancy of the dwelling or six months after the sale of the product by an independent, authorized HHT dealer/ distributor, whichever occurs earlier. The warranty shall commence no later than 24 months following the date of product shipment from HHT, regardless of the installation or occupancy date. The warranty period for parts and labor for covered components is produced in the following table.

The term "Limited Lifetime" in the table below is defined as: 20 years from the beginning date of warranty coverage for gas appliances, and 10 years from the beginning date of warranty coverage for wood, pellet, and coal appliances. These time periods reflect the minimum expected useful lives of the designated components under normal operating conditions.

Warranty Period		HHT Manufactured Appliances and Venting							Components Covered
Parts	Labor	Gas	Wood	Pellet	EPA Wood	Coal	Electric	Venting	
1 Year		X	X	X	X	X	X	X	All parts and material except as covered by Conditions, Exclusions, and Limitations listed
2 years				X	X	X			Igniters, electronic components, and glass
		X	X	X	X	X			Factory-installed blowers
			X						Molded refractory panels
3 years				X					Firepots and burnpots
5 years	1 year			X	X				Castings and baffles
7 years	3 years		X	X	X				Manifold tubes, HHT chimney and termination
10 years	1 year	X							Burners, logs and refractory
Limited Lifetime	3 years	X	X	X	X	X			Firebox and heat exchanger
90 Days		X	X	X	X	X	X	X	All replacement parts beyond warranty period

See conditions, exclusions, and limitations on next page.

WARRANTY CONDITIONS:

- This warranty only covers HHT appliances that are purchased through an HHT authorized dealer or distributor. A list of HHT authorized dealers is available on the HHT branded websites.
- This warranty is only valid while the HHT appliance remains at the site of original installation.
- Contact your installing dealer for warranty service. If the installing dealer is unable to provide necessary parts, contact the nearest HHT authorized dealer or supplier. Additional service fees may apply if you are seeking warranty service from a dealer other than the dealer from whom you originally purchased the product.
- Check with your dealer in advance for any costs to you when arranging a warranty call. Travel and shipping charges for parts are not covered by this warranty.

WARRANTY EXCLUSIONS:

This warranty does not cover the following:

- Changes in surface finishes as a result of normal use. As a heating appliance, some changes in color of interior and exterior surface finishes may occur. This is not a flaw and is not covered under warranty.
- Damage to printed, plated, or enameled surfaces caused by fingerprints, accidents, misuse, scratches, melted items, or other external sources and residues left on the plated surfaces from the use of abrasive cleaners or polishes.
- Repair or replacement of parts that are subject to normal wear and tear during the warranty period. These parts include: paint, wood, pellet and coal gaskets; firebricks; grates; flame guides; and the discoloration of glass.
- Minor expansion, contraction, or movement of certain parts causing noise. These conditions are normal and complaints related to this noise are not covered by this warranty.
- Damages resulting from: (1) failure to install, operate, or maintain the appliance in accordance with the installation instructions, operating instructions, and listing agent identification label furnished with the appliance; (2) failure to install the appliance in accordance with local building codes; (3) shipping or improper handling; (4) improper operation, abuse, misuse, continued operation with damaged, corroded or failed components, accident, or improperly/incorrectly performed repairs; (5) environmental conditions, inadequate ventilation, negative pressure, or drafting caused by tightly sealed constructions, insufficient make-up air supply, or handling devices such as exhaust fans or forced air furnaces or other such causes; (6) use of fuels other than those specified in the operating instructions; (7) installation or use of components not supplied with the appliance or any other components not expressly authorized and approved by HHT; (8) modification of the appliance not expressly authorized and approved by HHT in writing; and/or (9) interruptions or fluctuations of electrical power supply to the appliance.
- Non-HHT venting components, hearth components or other accessories used in conjunction with the appliance.
- Any part of a pre-existing fireplace system in which an insert or a decorative gas appliance is installed.
- HHT's obligation under this warranty does not extend to the appliance's capability to heat the desired space. Information is provided to assist the consumer and the dealer in selecting the proper appliance for the application. Consideration must be given to appliance location and configuration, environmental conditions, insulation and air tightness of the structure.

This warranty is void if:

- The appliance has been over-fired or operated in atmospheres contaminated by chlorine, fluorine, or other damaging chemicals. Over-firing can be identified by, but not limited to, warped plates or tubes, rust colored cast iron, bubbling, cracking and discoloration of steel or enamel finishes.
- The appliance is subjected to prolonged periods of dampness or condensation.
- There is any damage to the appliance or other components due to water or weather damage which is the result of, but not limited to, improper chimney or venting installation.

LIMITATIONS OF LIABILITY:

- The owner's exclusive remedy and HHT's sole obligation under this warranty, under any other warranty, express or implied, or in contract, tort or otherwise, shall be limited to replacement, repair, or refund, as specified above. In no event will HHT be liable for any incidental or consequential damages caused by defects in the appliance. Some states do not allow exclusions or limitation of incidental or consequential damages, so these limitations may not apply to you. This warranty gives you specific rights; you may also have other rights, which vary from state to state. **EXCEPT TO THE EXTENT PROVIDED BY LAW, HHT MAKES NO EXPRESS WARRANTIES OTHER THAN THE WARRANTY SPECIFIED HEREIN. THE DURATION OF ANY IMPLIED WARRANTY IS LIMITED TO DURATION OF THE EXPRESSED WARRANTY SPECIFIED ABOVE.**

For Service or Replacement Parts Contact:

Melbourne

Jetmaster
444 Swan Street
Richmond 3121
(03) 9429-5573

Perth

Fireplace Corner
277 Lord Street
East Perth 6000
(08) 9228-2600

Sydney

Jetmaster
10 Martin Avenue
Arncliffe 2205
(02) 9597-7222