

This appliance has been retired.
Service parts pages within have been removed.
For replacement parts, please refer to the individual
service parts list located on the brand websites.

HEAT-N-GLO

No one builds a better fire

INSTALLATION AND OPERATION INSTRUCTIONS

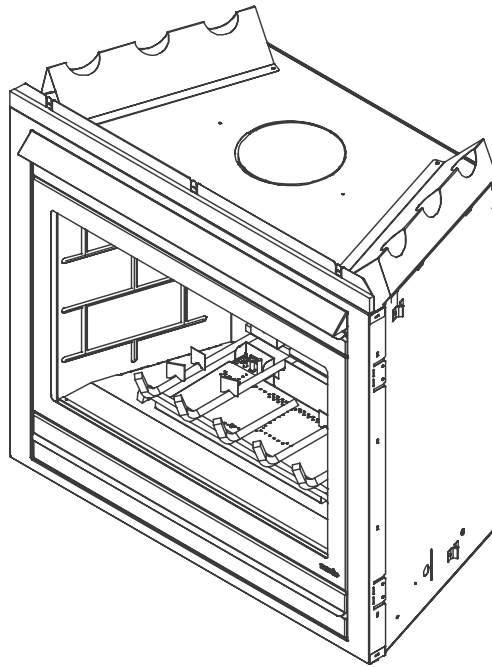

MODEL: 6000TRS-AU

AUSTRALIAN GAS ASSOCIATION APPROVED

AGA APPROVAL NUMBER 5668

**THIS MANUAL MUST BE USED FOR INSTALLATION AND RETAINED
BY HOMEOWNER FOR OPERATION AND MAINTENANCE.**

HEAT-N-GLO, a division of Hearth Technologies Inc.

20802 Kensington Boulevard, Lakeville, MN 55044, USA 1-888-427-3973

This product is covered by one or more of the following patents: (United States) 4,112,913; 4,408,594; 4,422,426; 4,424,792; 4,520,791; 4,793,322; 4,852,548; 4,875,464; 5,000,162; 5,016,609; 5,076,254; 5,191,877; 5,218,953; 5,328,356; 5,429,495; 5,452,708; 5,542,407; 5,613,487; (Australia) 543790; 586383; (Canada) 1,123,296; 1,297,746; 2,195,264; (Mexico) 97-0457; (New Zealand) 200265; or other U.S. and foreign patents pending.

392-900D 10/02



INSTALLATION AND OPERATION INSTRUCTIONS

PLEASE READ THIS MANUAL BEFORE INSTALLING AND USING THIS APPLIANCE.

**MODEL 6000TRS-AU
IS AUSTRALIAN GAS ASSOCIATION
APPROVED FOR NATURAL GAS OR PROPANE
AS A BALANCED FLUE HEATER.**

Refer to the appliance data plates for gas consumptions and pressures.

Installation of this appliance should only be carried out by an authorized person in accordance with the manufacturers instructions. All relevant codes and regulations laid down by the gas fitting authorities, municipal building regulations, electrical wiring regulations, and the requirements of the AGA Gas Installation Code must be observed.

This appliance and its components are tested and safe when installed in accordance with this Installation Manual. Report to your dealer any parts damaged in shipment, specifically check glass condition. The gas logs and flue system components are in separate packages. Read all instructions before starting installation and follow these instructions carefully during installation to ensure maximum benefit and safety. Failure to follow them will void your warranty and may present a fire hazard.

The Heat-N-Glo warranty will be voided by, and Heat-N-Glo disclaims any responsibility for the following actions:

- Installation of any damaged heater or flue system component
- Modification of the heater or balanced flue system installation other than as instructed by Heat-N-Glo.
- Improper positioning of the gas logs or the glass door
- Installation and/or use of any component part not manufactured or approved by Heat-N-Glo, not withstanding any independent testing laboratory or other party approval of such component part or accessory.

IMPORTANT: Read all instructions carefully before starting installation. Failure to follow these installation instructions may result in a possible fire hazard and will void the warranty. Save this manual for future reference.

TABLE OF CONTENTS

1.0 INSTALLATION INSTRUCTIONS.	4
1.1 Locating the Heater	5
◆ 1.2 Framing the Heater	6
1.3 Flue System Approvals and Installations	8
1.4 Connecting the Gas Supply	16
1.5 Fan	17
◆ 1.6 Mantel Clearances	18
1.7 Log Placement	19
1.8 Installer Testing	21
2.0 OPERATING INSTRUCTIONS.	21
2.1 Safety and Lighting Information	23
2.2 Safety Information	23
◆ 2.3 Lighting Instructions	24
2.4 Fan Operation	25
3.0 SERVICING AND MAINTENANCE.	25
3.1 Removal of Covers for Servicing	26
3.2 Removal of Components for Service	26
3.3 Parts Replacement	26
3.4 Adjustments and Replacement Parts	26
◆ 3.5 Troubleshooting	27
4.0 REPLACEMENT PARTS.	31
Limited Warranty	33

◆ = Contains updated information.

1.0 INSTALLATION INSTRUCTIONS

When planning a heater installation, it's necessary to determine:

- Where the unit is to be installed.
- The vent system configuration to be used.
- Gas supply piping.
- Electrical wiring.
- Framing and finishing details.

- Whether optional accessories—devices such as a fan, wall switch, or remote control—are desired.

If the heater is to be installed on carpeting or tile, or on any combustible material other than wood flooring, the heater should be installed on a metal or wood panel that extends the full width and depth of the heater.

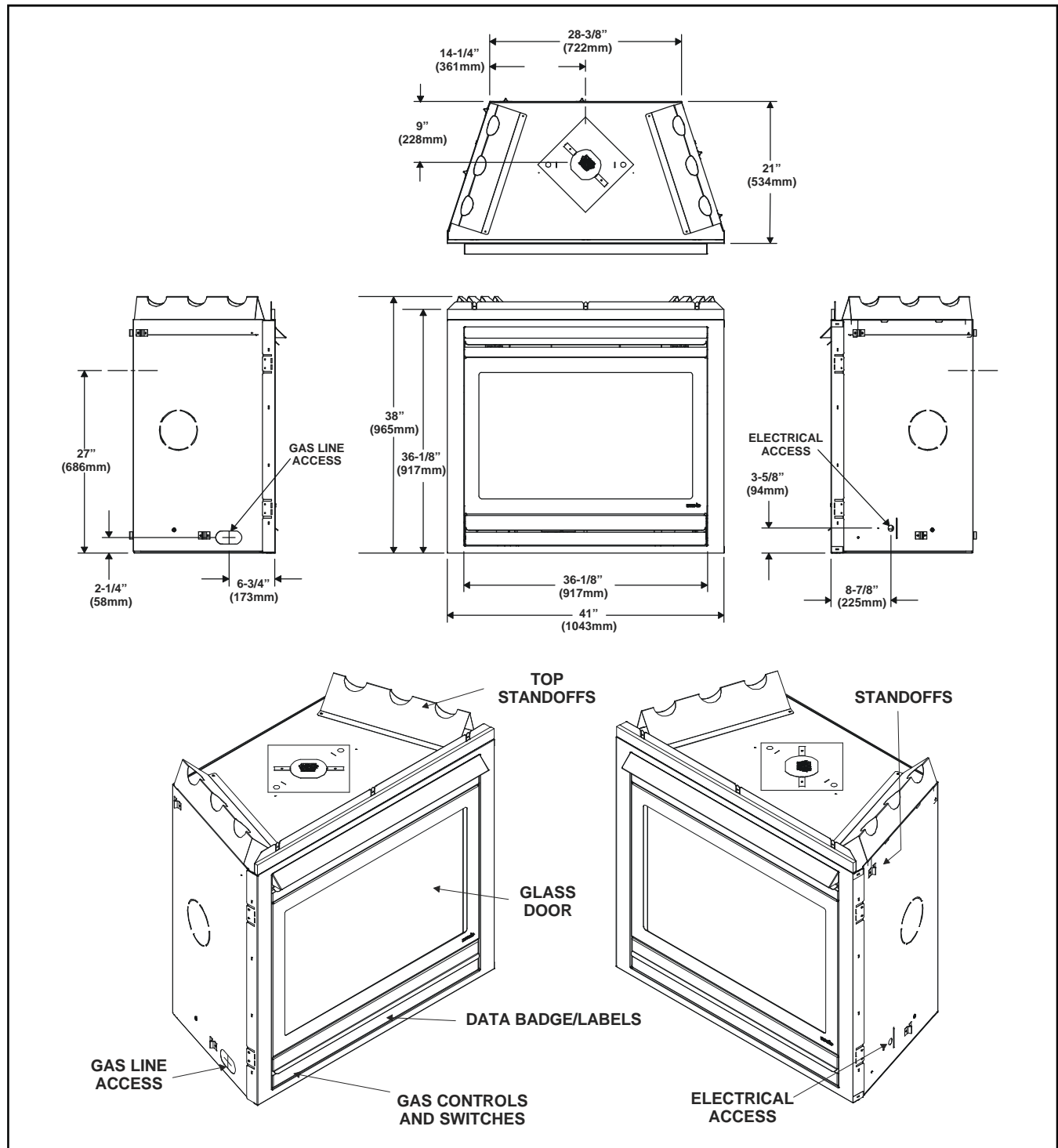

FIGURE 1. Diagram of the 6000 Series

1.1 Locating the Heater

The diagram (See figure 2) shows space and clearance requirements for locating a heater within a room.

Clearance Requirements

The top, back, and sides of the heater are defined by stand-offs.

The minimum clearance to a perpendicular wall extending past the face of the heater is one inch (25 mm).

For 6000 Series Models, the back of the heater may be recessed 21-1/2 inches (546 mm) into combustible construction.

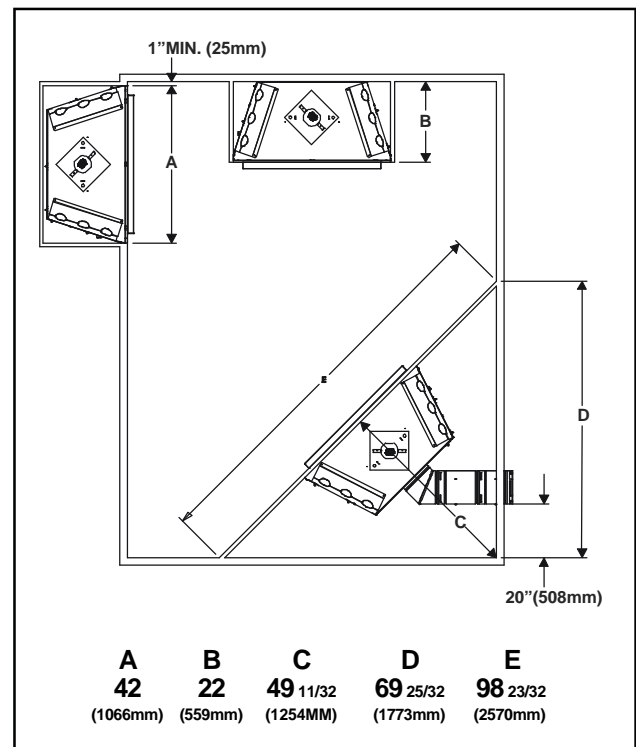

FIGURE 2. Heater Dimensions, Locations, and Space Requirements

Minimum Clearances from the Heater to Combustible Materials					
Glass Front	Floor	Back of Heater	Sides of Heater	Top of Heater	Ceiling
36 inches (914 mm)	0	1/2 inch (13 mm)	1/2 inch (13 mm)	3-1/2 inches (89 mm)	31 inches (787 mm)

Minimum Clearances from the Flue Pipe to Combustible Materials						
For Horizontal Sections			For Vertical Sections	At Wall Firestops		
Top	Bottom	Sides	1 inch (25 mm)	Top	Bottom	Sides
3 inches (75 mm)	1 inch (25 mm)	1 inch (25 mm)			2-1/2 inches (63.7 mm)	1/2 inch (13 mm)

For minimum clearances, see the direct vent termination clearance diagrams on page 7.

1.2 Framing the Heater

Framing can be built before or after the heater is set in place. Framing should be positioned to accommodate wall coverings and heater facing material. The diagram below shows framing reference dimensions.

CAUTION: MEASURE HEATER DIMENSIONS AND VERIFY FRAMING METHODS AND WALL COVERING DETAILS, BEFORE FRAMING CONSTRUCTION BEGINS.

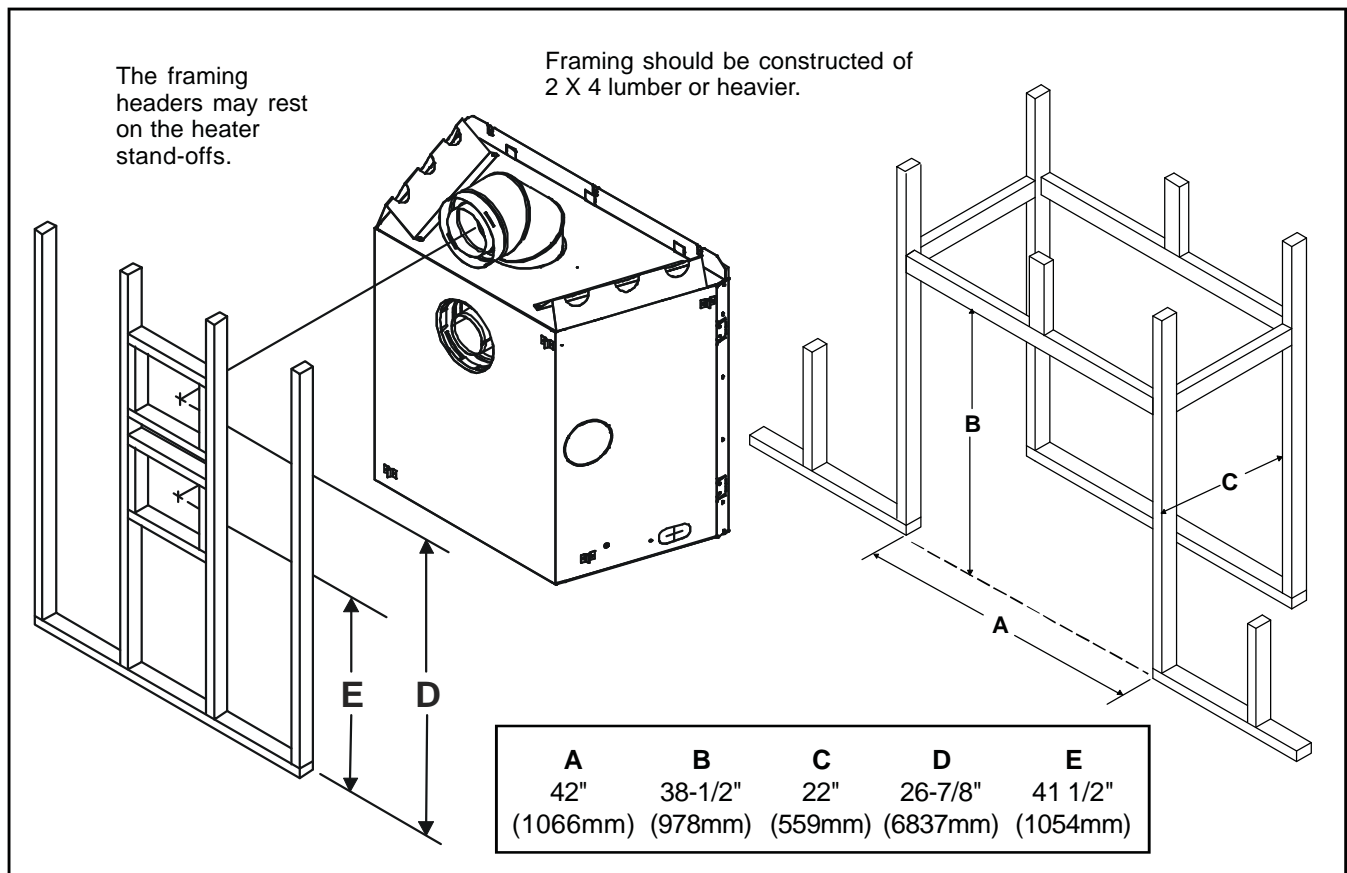

◆ FIGURE 3. Framing Dimensions

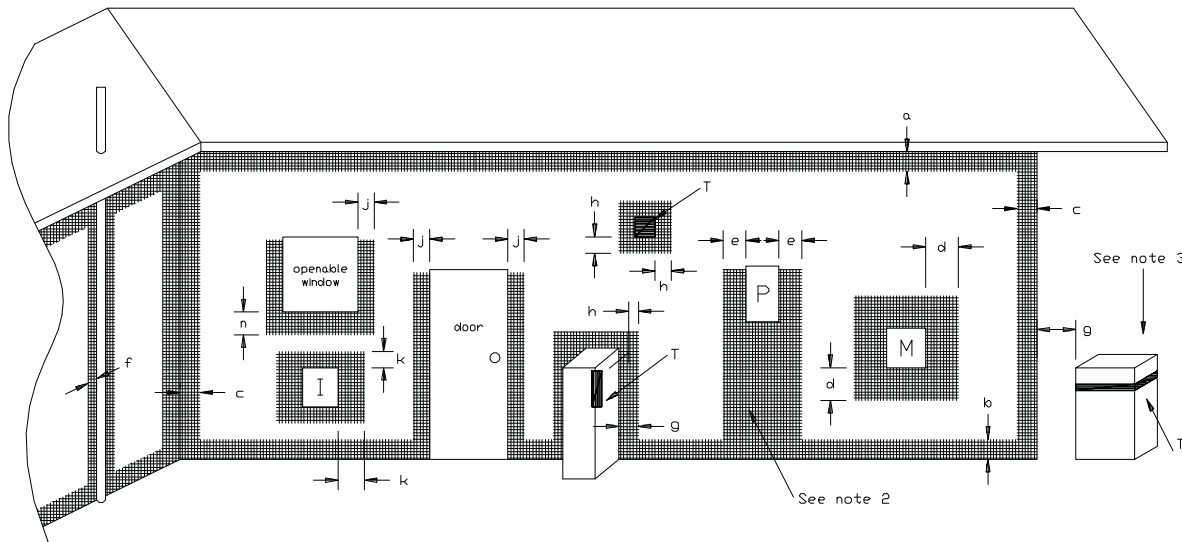

T = Flue terminal
 I = Mechanical air inlet
 M = Gas meter
 P = Electricity meter or fuse box
 Shading indicates prohibited areas for flue terminals

- a - Below eaves, balconies or other projections: **MIN. CLEARANCE (mm)**
 Appliances up to 50 MJ/h input 300
 Appliances over 50 MJ/h input 500
- b - From the ground or above a balcony 300
- c - From a return wall or external corner 500
- d - From a gas meter (M) 1000
- e - From an electricity meter or fuse box (P) 500
- f - From a drain or soil pipe 150
- g - Horizontally from any building structure (unless appliance approved for closer installation) or obstruction facing a terminal 500
- h - From any other flue terminal, cowl, or combustion air intake 500
- j - Horizontally from an openable window, door, non-mechanical air inlet, or any other opening into a building, with the exception of sub-floor ventilation:
 Appliances up to 150 MJ/h input 500
 Appliances over 150 MJ/h input 1500
- k - From a mechanical air inlet, including a spa blower 1500
- n - Vertically below an openable window, non-mechanical air inlet or any other opening into a building, with the exception of See table sub-floor ventilation below

CLEARANCES 'n' (mm)			
Space heaters	All other appliances		
Up to 50 MJ/h input	UP to 50 MJ/h input	Over 50 MJ/h & up to 150 MJ/h	Over 150 MJ/h input
150	500	1000	1500

- NOTES:**
- All distances are measured vertically or horizontally along the wall to a point in line with the nearest part of the terminal.
 - Prohibited area below electricity meter or fuse box extends to ground level.
 - See clause 5.13.6.6 for restrictions on a flue terminal under a roofed area.
 - See Appendix J, Figure J1(a) and J2(a) for clearances required from a flue terminal to a LP Gas cylinder. A flue terminal is considered to be a source of ignition.

**MINIMUM CLEARANCES REQUIRED FOR BALANCED FLUE TERMINALS
 OR THE FLUE TERMINALS OF OUTDOOR APPLIANCES**

FIGURE 4.

MODEL	FLUE TERMINATION APPROVALS
6000TRS-AU	DVK-01DA, DVK-TVCD
TABLE 1	DVK-01TRD

1.3 FLUE SYSTEM APPROVALS AND INSTALLATIONS

This model is approved to use D-Series flue pipe components. A DVK-01DA or DVK-01TRD Termination Cap must be used to terminate vent systems in a horizontal position. A DVK-TVCD vertical Termination Cap must be used to terminate vent systems in a vertical position.

Figures 5 through 14 show the flue systems approved for use with these models. Approved flue system components are labeled for identification. **NO OTHER FLUE SYSTEMS OR COMPONENTS MAY BE USED.** Detailed installation instructions are included with each flue termination kit and should be used in conjunction with this manual.

WARNING: THIS GAS APPLIANCE AND FLUE ASSEMBLY MUST BE FLUED DIRECTLY TO THE OUTSIDE AND MUST NEVER BE ATTACHED TO A CHIMNEY SERVING A SEPARATE SOLID FUEL BURNING APPLIANCE. EACH GAS APPLIANCE MUST USE A SEPARATE FLUE SYSTEM-COMMON FLUE SYSTEMS ARE PROHIBITED.

CAUTION: UNDER NO CONDITION SHOULD COMBUSTIBLE MATERIAL BE CLOSER THAN 3 INCHES (2 1/2 INCHES AT WALL FIRESTOPS) FROM THE TOP OF THE 8 5/8-INCH PIPE OR 1-INCH TO THE SIDES AND THE BOTTOM FOR HORIZONTAL SECTIONS OF THIS FLUE SYSTEM. VERTICAL SECTIONS OF THIS SYSTEM REQUIRE A MINIMUM OF 1-INCH CLEARANCE TO COMBUSTIBLE MATERIALS ALL AROUND THE 8 5/8 - INCH PIPE.

For alternative installations, other than depicted, contact your dealer for further information.

Refer to Figure 4 for required clearances to flue terminals.

STRAIGHT UP VERTICAL FLUE SYSTEM

Figure 5 shows straight up vertical flue system approved for use on this model.

STRAIGHT OUT HORIZONTAL FLUE SYSTEM

Figure 6 shows straight out horizontal flue systems approved for use on this model.

ELBOWS

The flue systems installed on this gas heater may also include one (1), two (2), or three (3) 90 - degree elbow assemblies.

Figures 7 through 14 and their corresponding tables show examples of vent configurations using elbows. The relationships of vertical rise to horizontal run in vent configurations using elbows **MUST** be strictly adhered to.

NOTE: TWO 45-DEGREE ELBOWS MAY BE USED IN PLACE OF ONE 90 -DEGREE ELBOW.

CAUTION: DO NOT INSTALL A 45-DEGREE ELBOW DIRECTLY TO THE HEATER FOR A CORNER INSTALLATION. USE TWO 90-DEGREE ELBOWS.

ONE (1) 90-DEGREE ELBOW

Figures 6 and 7 show an installation using one (1) 90-degree elbow. Dimension V is listed as **MINIMUM** vertical dimensions and dimension H is listed as corresponding **MAXIMUM** horizontal dimensions.

TWO (2) 90-DEGREE ELBOWS

Figures 9 and 10 show examples of possible installations using two (2) 90-degree elbows. Dimension V is listed as **MINIMUM** vertical dimensions, dimension H is listed as **MAXIMUM** beginning horizontal dimensions, and dimension $H+H_1$ is listed as corresponding **TOTAL MAXIMUM** horizontal dimensions.

THREE (3) 90-DEGREE ELBOWS

Figures 12 through 14 show examples of possible installations using three (3) 90-degree elbows. Dimensions V are listed **MINIMUM** first vertical dimensions and dimensions H are listed as beginning **MAXIMUM** horizontal dimensions. Dimensions $H+H_1$ and $H+H_1+H_2$ are listed as **TOTAL MAXIMUM** horizontal dimensions. Dimensions $V+V_1$ are listed as **TOTAL MAXIMUM** vertical dimensions.

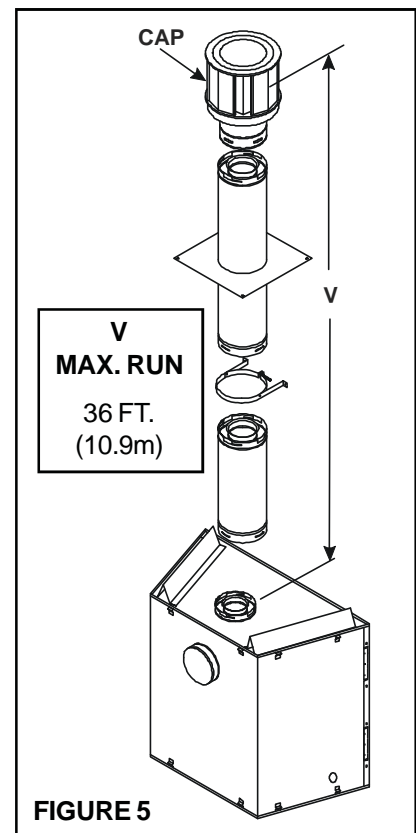

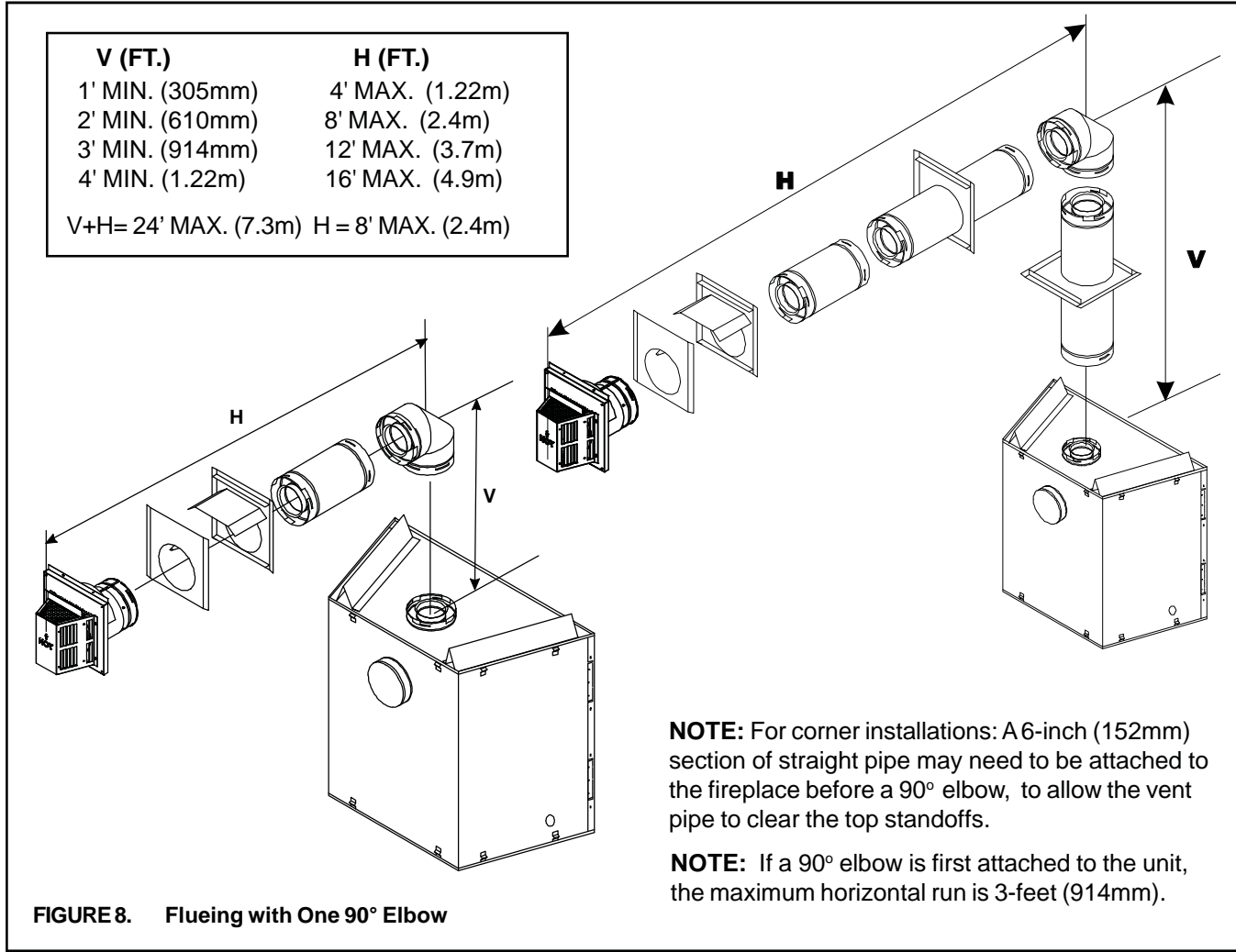
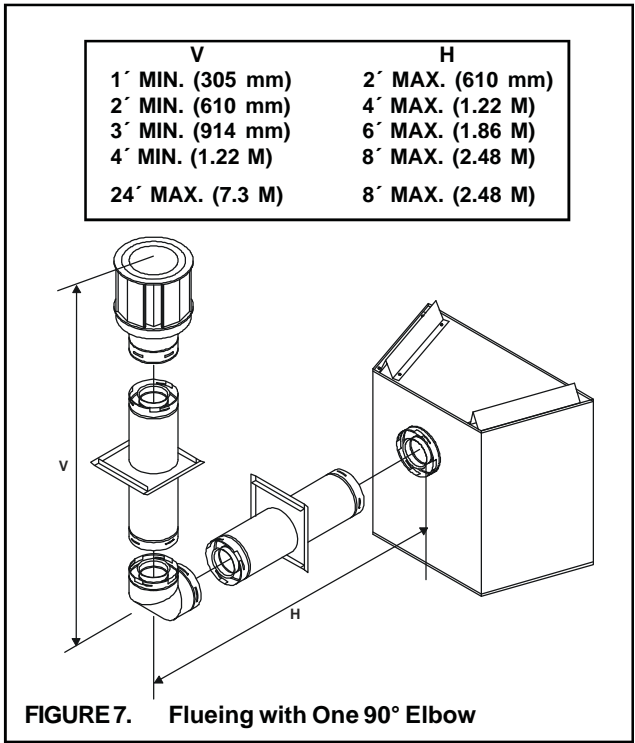
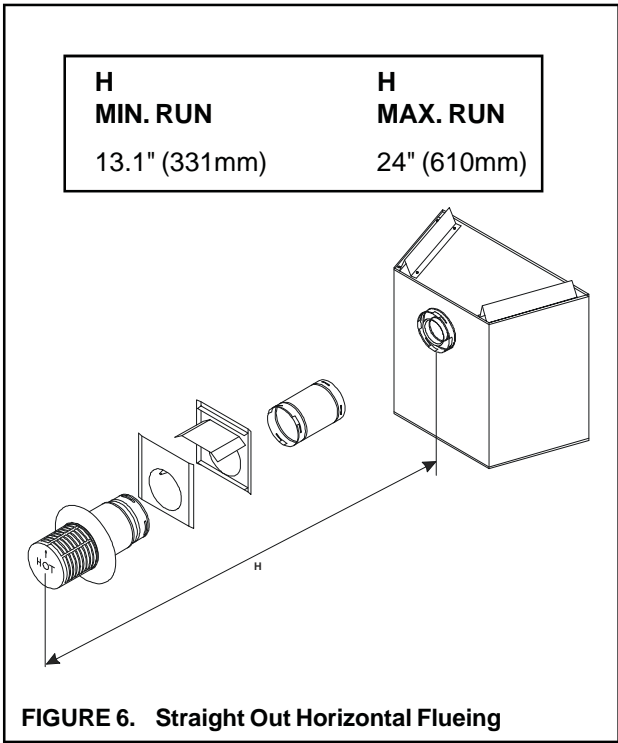

V FT.)	H (FT.)	H+H ₁ (FT.)
1' MIN. (350mm)	2' MAX. (610mm)	4' MAX. (1.22m)
2' MIN. (610mm)	2' MAX. (610mm)	8' MAX. (2.48m)
3' MIN. (914mm)	4' MAX. (1.22m)	12' MAX. (3.72m)
4' MIN. (1.22m)	6' MAX. (1.8m)	16' MAX. (4.9m)
20' MAX. (6.1m)	6' MAX. (1.8m)	16' MAX. (4.9m)

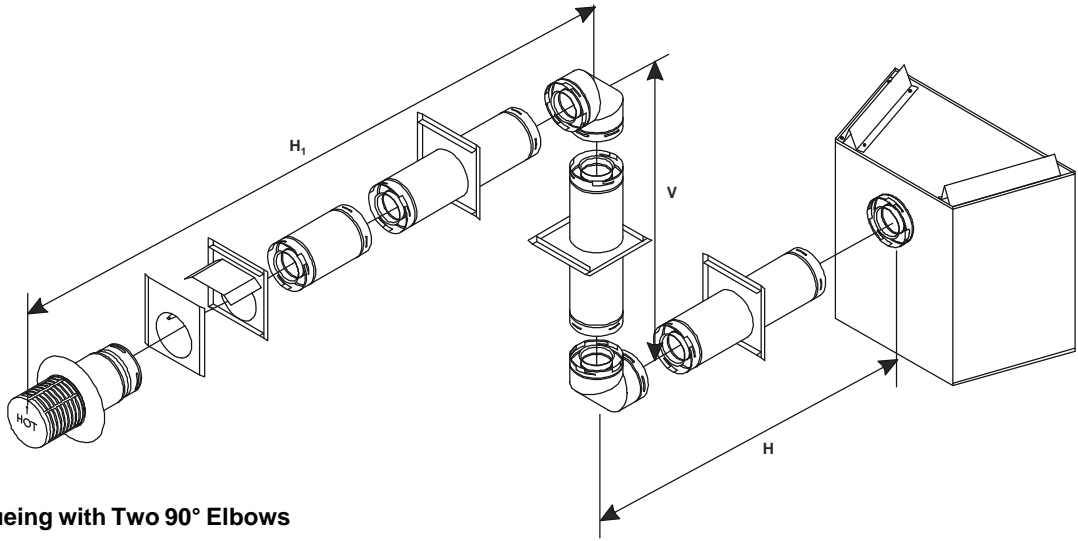

FIGURE 9. Flueing with Two 90° Elbows

V FT.	H + H ₁ (FT.)
1' MIN. (305mm)	4' MAX. (1.22m)
2' MIN. (610mm)	8' MAX. (2.4m)
3' MIN. (914mm)	12' MAX. (3.7m)
4' MIN. (1.22m)	16' MAX. (4.9m)
V+H+H ₁ = 36' MAX.(10.9m)	H+H ₁ = 16' MAX. (4.9m)
V+V ₁ +H= 36' MAX.(10.9m)	

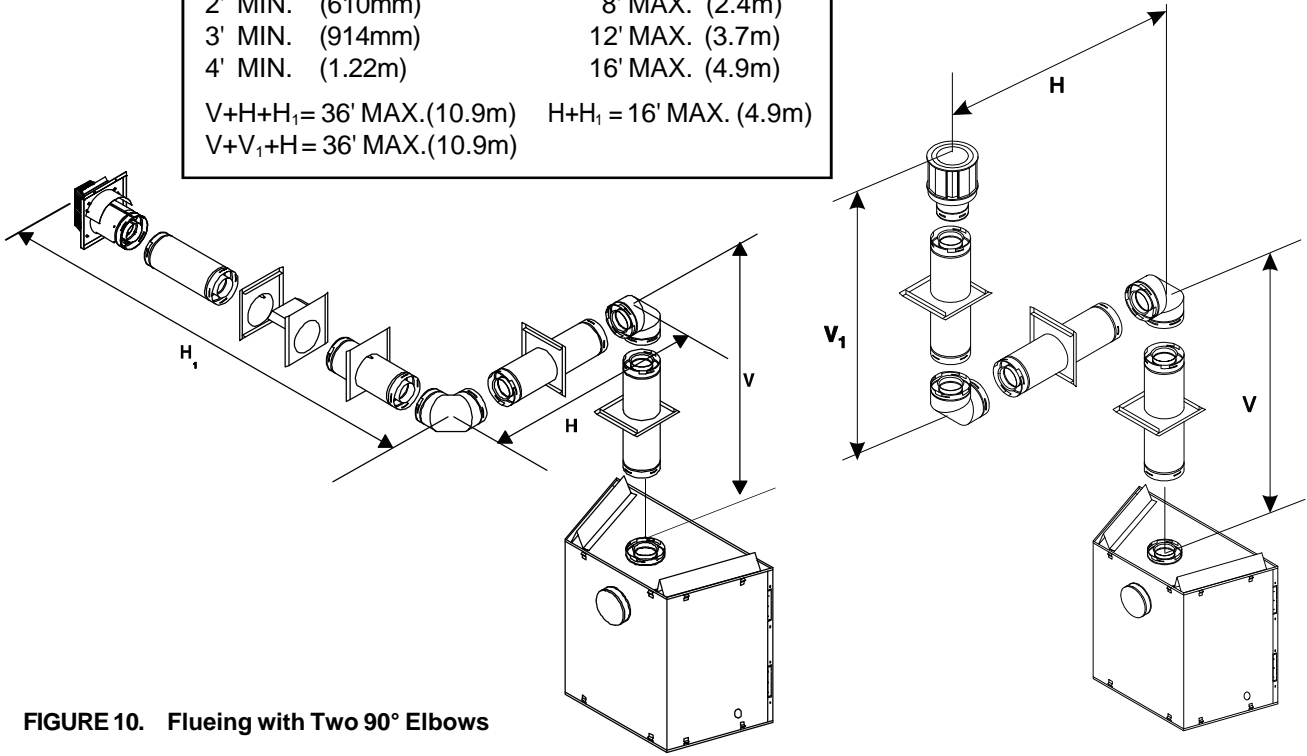
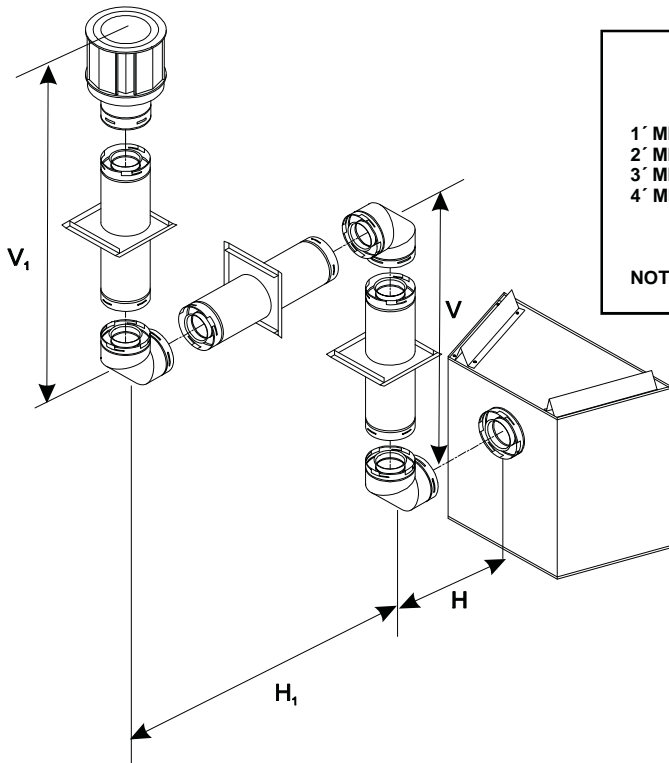

FIGURE 10. Flueing with Two 90° Elbows



FLUEING WITH THREE (3) 90° ELBOWS		
V	H	H + H ₁
1' MIN. (305 mm)	2' MAX. (610 mm)	4' MAX. (1.22 m)
2' MIN. (610 mm)	4' MAX. (1.22 m)	8' MAX. (2.48 m)
3' MIN. (914 mm)	6' MAX. (1.86 m)	12' MAX. (3.6 m)
4' MIN. (1.22 m)	8' MAX. (2.48 m)	16' MAX. (4.9 m)
	8' MAX. (2.48 m)	16' MAX. (4.9 m)

NOTE: V + V, MAX. 36' (10.9 m)

FIGURE 11. Flueing with three 90° elbows

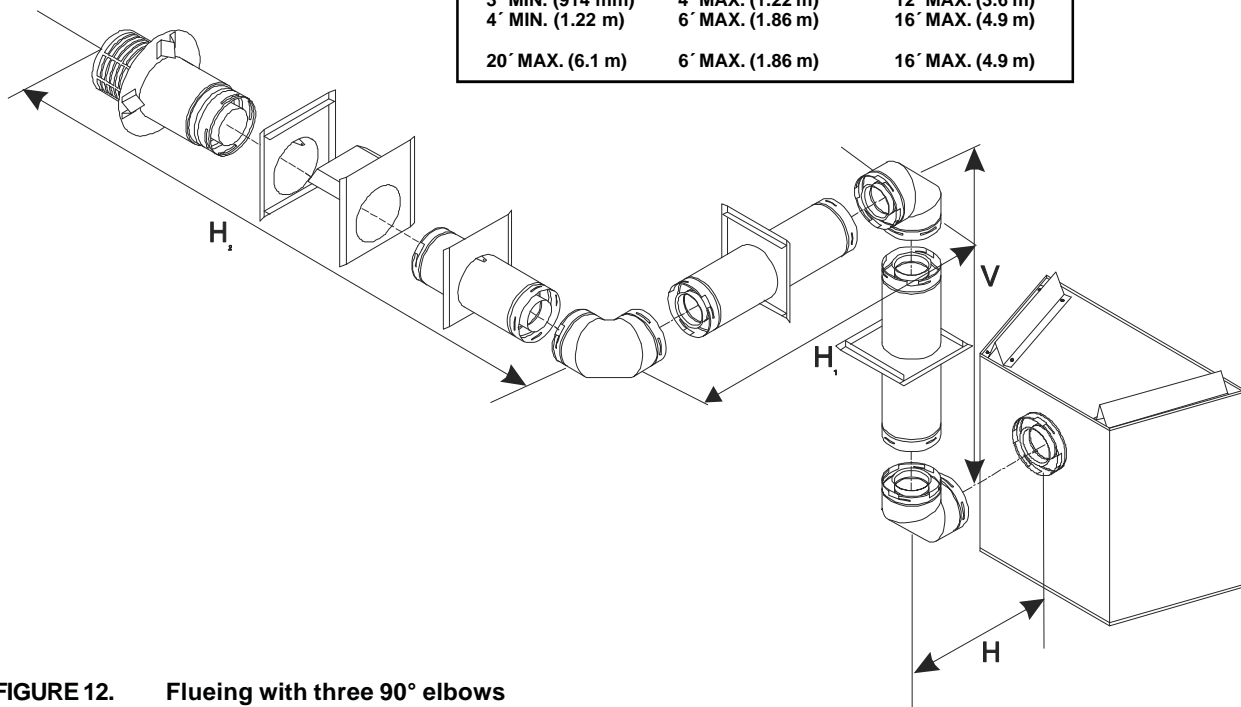

FLUEING WITH THREE (3) 90° ELBOWS		
V	H	H + H ₁ + H ₂
1' MIN. (305 mm)	2' MAX. (610 mm)	4' MAX. (1.22 m)
2' MIN. (610 mm)	2' MAX. (610 mm)	8' MAX. (2.48 m)
3' MIN. (914 mm)	4' MAX. (1.22 m)	12' MAX. (3.6 m)
4' MIN. (1.22 m)	6' MAX. (1.86 m)	16' MAX. (4.9 m)
20' MAX. (6.1 m)	6' MAX. (1.86 m)	16' MAX. (4.9 m)

FIGURE 12. Flueing with three 90° elbows

VENTING WITH THREE (3) 90° ELBOWS

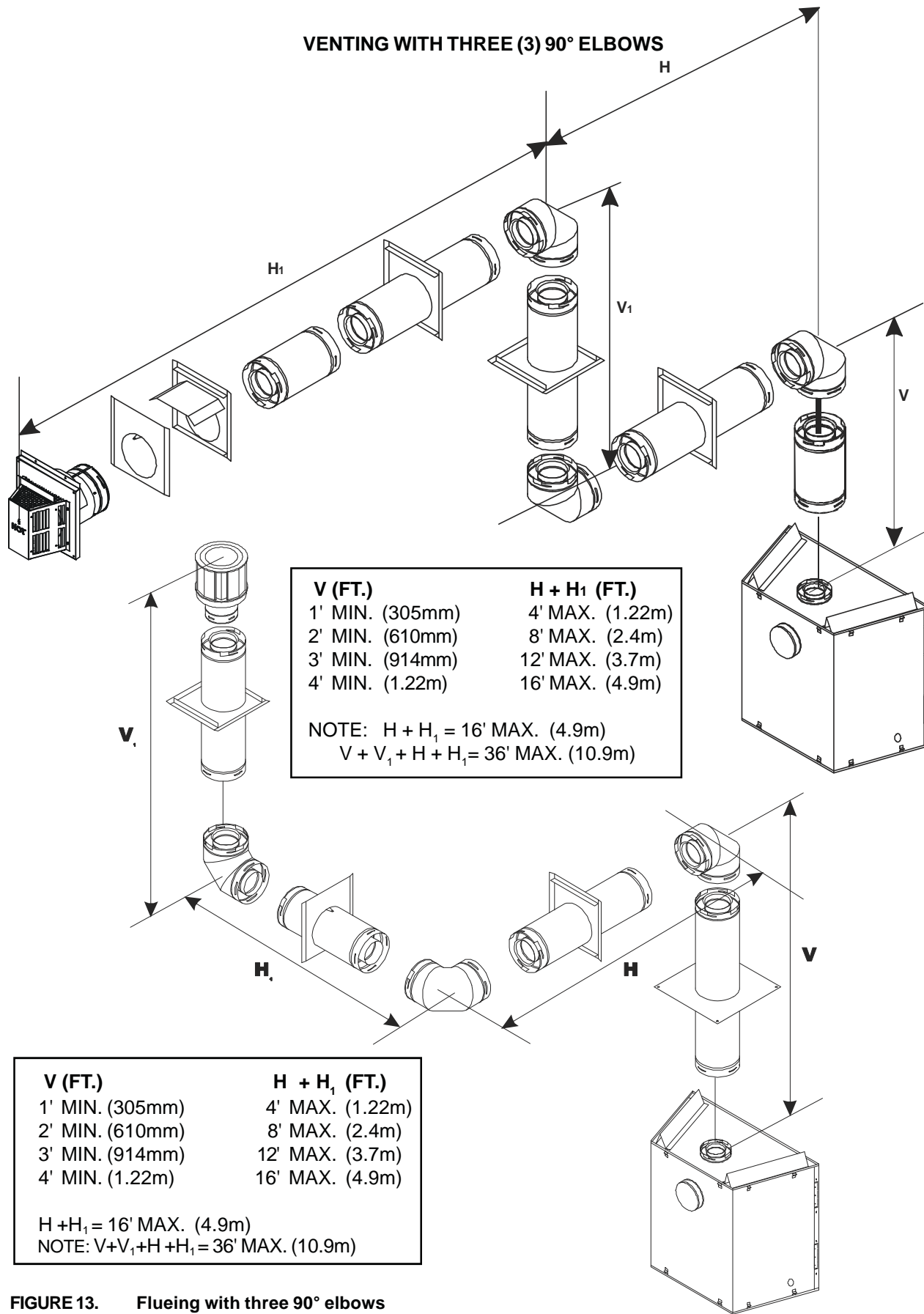

FIGURE 13. Flueing with three 90° elbows

Installing Flue Components

1. Attach the First Flue Component to the Starting Collars

To attach the first flue component to the starting collars of the fireplace:

- Apply a 3/8 inch (10mm) bead of stove cement around the inner pipe heater starting collar.
- Make sure that the heater rope gasket supplied with the heater seals between the first flue component and the outer heater wrap.
- Lock the flue components into place by sliding the concentric pipe sections with four (4) equally spaced interior beads into the heater collar or previously installed component end with four (4) equally spaced indented sections.
- When the internal beads of each outer pipe line up, rotate the pipe section clockwise about one-quarter (1/4) turn. The flue pipe is now locked together.
- The first 90° elbow installed in the flue system of a rear flueing heater **MUST BE** in a vertical position.

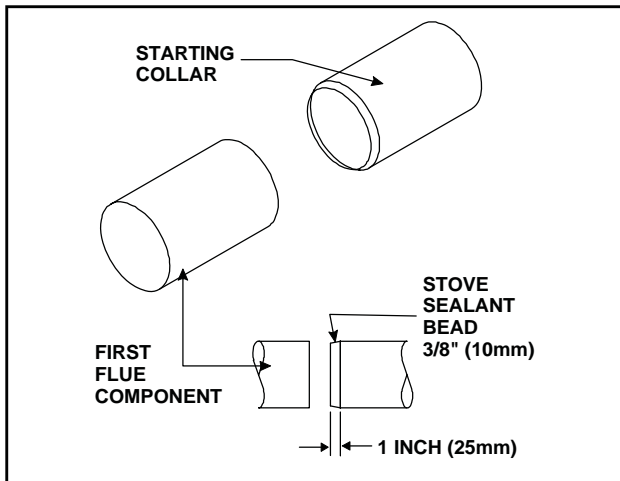

FIGURE 14. Attaching the First Flue Component to the Starting Collars



WARNING: A 3/8 INCH (10MM) BEAD OF STOVE CEMENT MUST BE PLACED AROUND THE INNER PIPE HEATER STARTING COLLAR BEFORE ATTACHING THE FIRST FLUE COMPONENT. FAILURE TO SEAL THIS JOINT MAY CAUSE THE HEATER TO OPERATE IMPROPERLY. SEE FIGURE 14.

WARNING: ENSURE THAT THE FIBER-GLASS ROPE GASKET SUPPLIED WITH THE HEATER SEALS BETWEEN THE FIRST FLUE COMPONENT AND THE OUTER HEATER WRAP.

2. Continue Adding Flue Components

To continue adding flue components in accordance with the pre-planned flue system configuration:

- Ensure that each succeeding flue component is securely fitted and locked into the preceding component in the flue system.

90° elbows may be installed and rotated to any point around the preceding component's vertical axis. If an elbow does not end up in a locked position with the preceding component, attach with a minimum of two (2) sheet metal screws.

3. Install Support Brackets

For Horizontal Runs - The flue system must be supported every five (5) feet of horizontal run by a horizontal pipe support.

To install support brackets for horizontal runs:

- Place the pipe supports around the flue pipe.
- Nail the pipe supports to the framing members.

For Vertical Runs

The flue system must be supported every eight (8) feet (2.4 M) above the heater flue outlet by wall brackets.

To install support brackets for vertical runs:

- Attach wall brackets to the flue pipe and secure the wall bracket to the framing members with nails or screws.

Use wall brackets to support vertical runs every 8 feet (2.4 M) above the heater flue outlet.

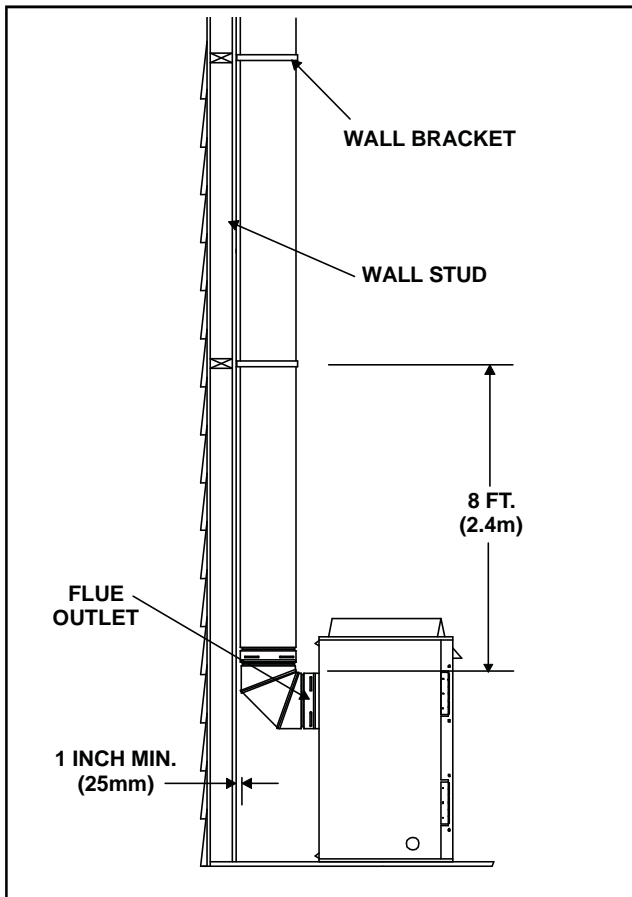

FIGURE 15. Installing Support Brackets

4. Install Firestops

For Horizontal Runs - Firestops are **REQUIRED** on both sides of a combustible wall through which the flue passes.

To install firestops for horizontal runs that pass through either interior or exterior walls:

- Cut a 12-inch by 12-inch (305 mm X 305 mm) hole through the wall. The center of the hole is one (1) inch (25mm) above the center of the horizontal flue pipe.

- Position the firestops on both sides of the hole previously cut and secure the firestops with nails or screws.

- The heat shields of the firestops **MUST BE** placed towards the top of the hole.

- Continue the flue run through the firestops.

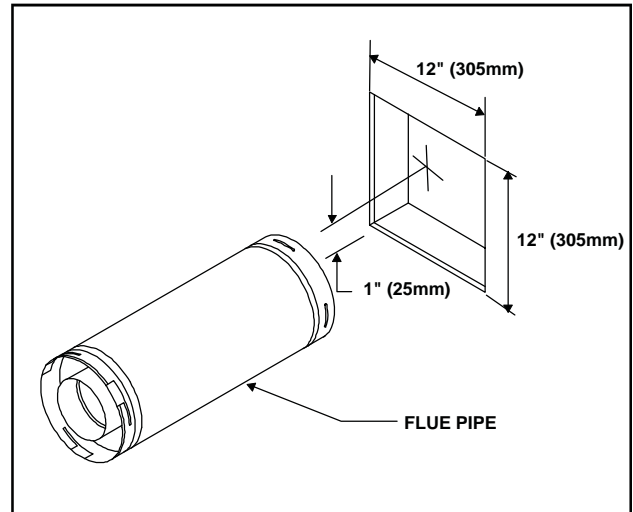

FIGURE 16. Hole and Flue Pipe

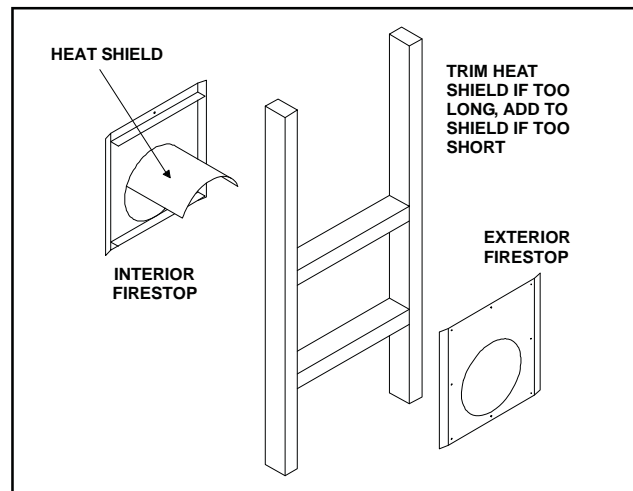

FIGURE 17. Heat Shield, Interior and Exterior Firestops

For Vertical Runs - One ceiling firestop is **REQUIRED** at the hole in each ceiling through which the flue passes.

To install firestops for vertical runs that pass through ceilings:

- Position a plumb bob directly over the center of the vertical flue component.
- Mark the ceiling to establish the centerpoint of the flue.

- Drill a hole or drive a nail through this center point.
- Check the floor above for any obstructions, such as wiring or plumbing runs.
- Reposition the heater and flue system, if necessary, to accommodate the ceiling joists and/or obstructions.
- Cut an 11-inch X 11-inch (280 mm X 280 mm) hole through the ceiling, using the center point previously marked.
- Frame the hole with framing lumber the same size as the ceiling joists.

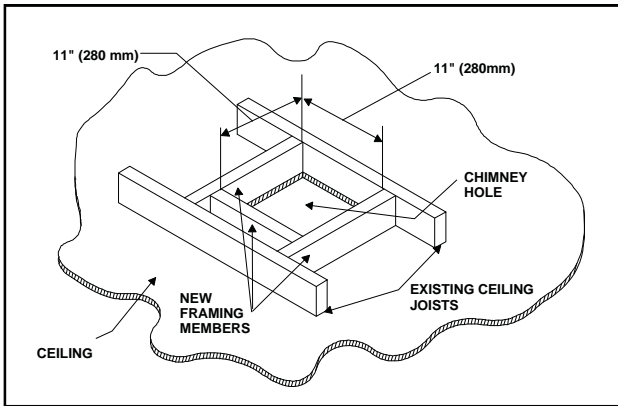

FIGURE 18. Hole and New Framing Members

If the area above the ceiling is **NOT** an attic, position and secure the ceiling firestop on the ceiling side of the previously cut and framed hole.

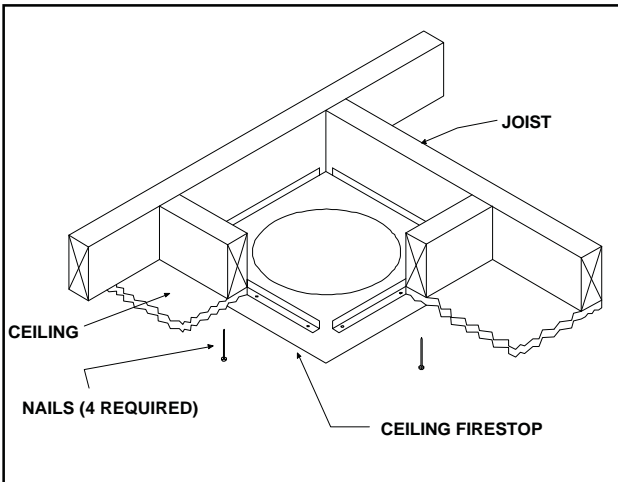

FIGURE 19. Ceiling Firestop (Ceiling Side)

If the area above the ceiling **IS** an attic, position and secure the firestop on top of the previously framed hole.

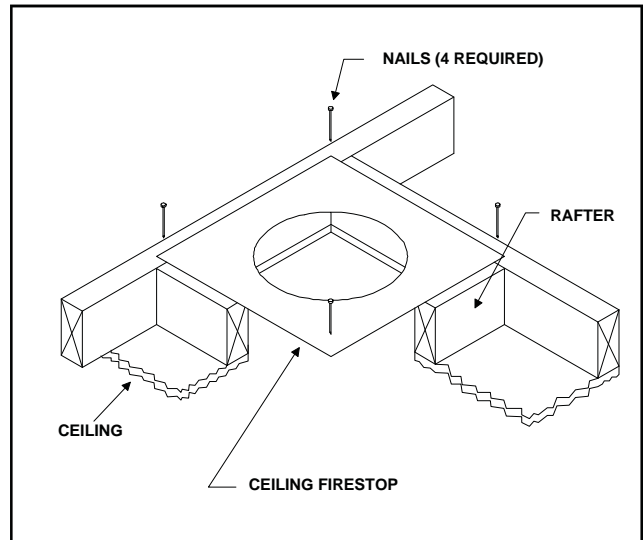

FIGURE 20. Attic Firestop

C. Flue Termination

For Horizontal Terminations - To attach and secure the termination to the last section of horizontal flue:

- Rotate and interlock the ends as described at the beginning of the Installing Flue Components section.
- The termination kit should pass through the wall firestops from the exterior of the building.
- Adjust the termination cap to its final exterior position on the building.



WARNING: THE TERMINATION CAP MUST BE POSITIONED SO THAT THE ARROW IS POINTING UP.

- Use the exterior pipelock hole provided on the round flange of the wall firestop to secure the flue pipe in place.
- Use a high-temperature sealant or fiberglass rope gasket to seal between the pipe and exterior firestop.
- See Figure 4 for flue termination clearances.

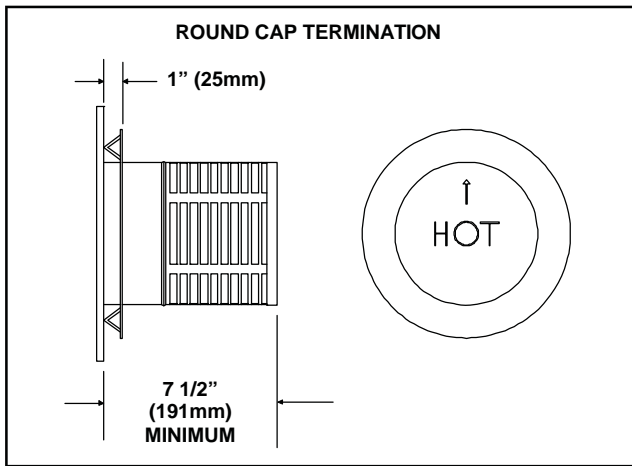

FIGURE 21. Round Termination Caps

For Vertical Terminations - To locate the flue and install the flue sections:

- Locate and mark the flue center point on the underside of the roof, and drive a nail through the center point.
- Make the outline of the roof hole around the center point nail.
- The size of the roof hole framing dimensions depend on the pitch of the roof. There **MUST BE** a 1-inch (25 mm) clearance from the vertical flue pipe to combustible materials.
- Mark the roof hole accordingly.
- Cover the opening of the installed flue pipes.
- Cut and frame the roof hole.
- Use framing lumber the same size as the roof rafters and install the frame securely. Flashing anchored to the frame must withstand heavy winds.
- Continue to install concentric flue sections up through the roof hole and up past the roof line until you reach the appropriate distance above the roof.

CAUTION: FOLLOW THE REQUIREMENTS OF THE AGA GAS INSTALLATION CODE FOR MINIMUM HEIGHT REQUIREMENTS ABOVE THE ROOF.

To seal the roof hole, and to divert rain and snow from the flue system:

- Attach a flashing to the roof using nails, and use a non-hardening mastic around the edges of the flashing base where it meets the roof.
- Attach a storm collar over the flashing joint to form a water-tight seal. Place non-hardening mastic around the joint, between the storm collar and the vertical pipe.
- Slide the termination cap over the end of the flue pipe and rotate the pipe clockwise 1/4 turn.

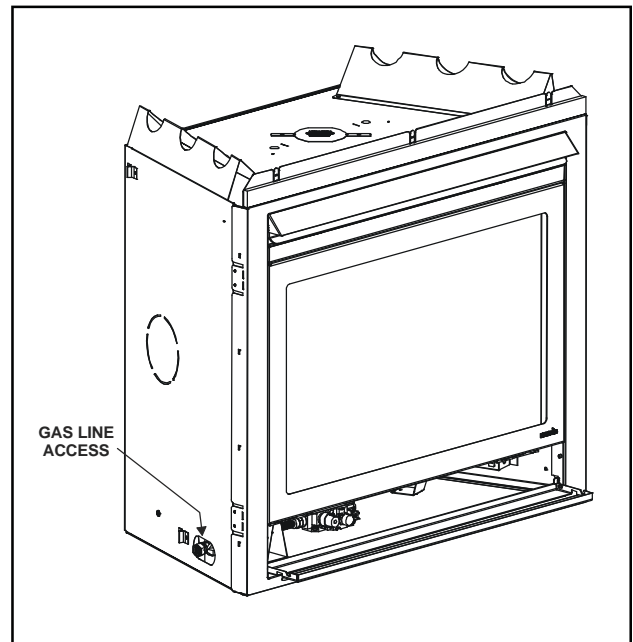

FIGURE 22.

1.4 CONNECTING THE GAS SUPPLY

The gas is introduced to the appliance on the left hand side. See Figure 22.

After the gas pipe installation is complete, check carefully all gas connections for leaks with a soap solution. **DO NOT USE AN OPEN FLAME.**

NOTE: THE GAS SUPPLY LINE SHOULD BE PURGED OF ANY TRAPPED AIR PRIOR TO THE FIRST FIRING OF THE UNIT.

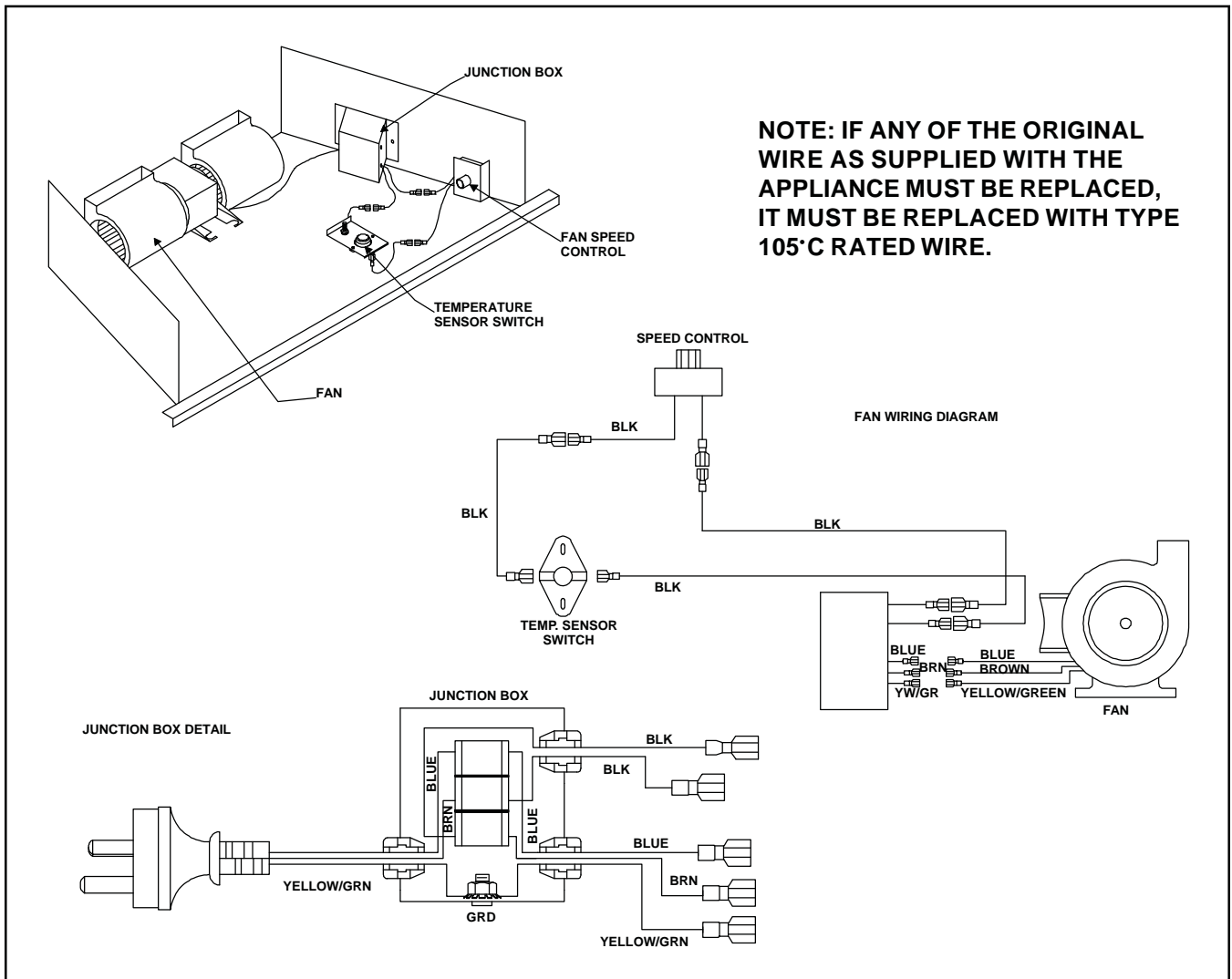

FIGURE 23.

1.5 FAN

These heaters have a factory installed Fan, Electrical Junction Boxes, variable speed Rheostat Control Switch and Temperature Sensor Switch for the fan. These components are located behind the lower grille.

Use of the fan requires that the Junction Box (factory installed) be connected to 240 VAC service before permanently enclosing the heater. The factory installed power cord is attached on the lower front right exterior side of the heater. Figure 23 shows the fan, switches, and fan wiring diagram. See Figure 24 for wire connection detail.

WARNING: DO NOT CONNECT 220 VAC TO THE GAS CONTROL VALVE OR CONTROL WIRING SYSTEM OF THIS MODEL.

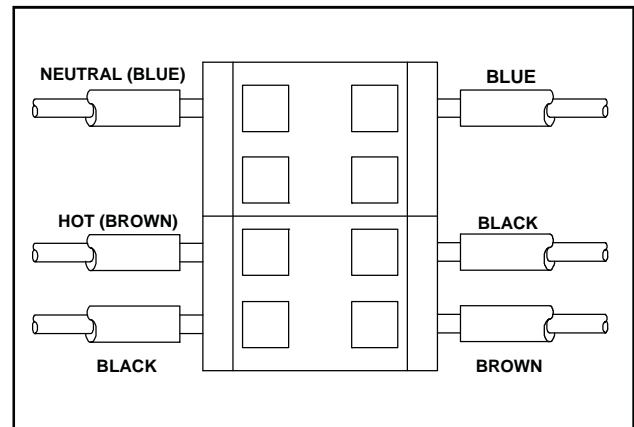
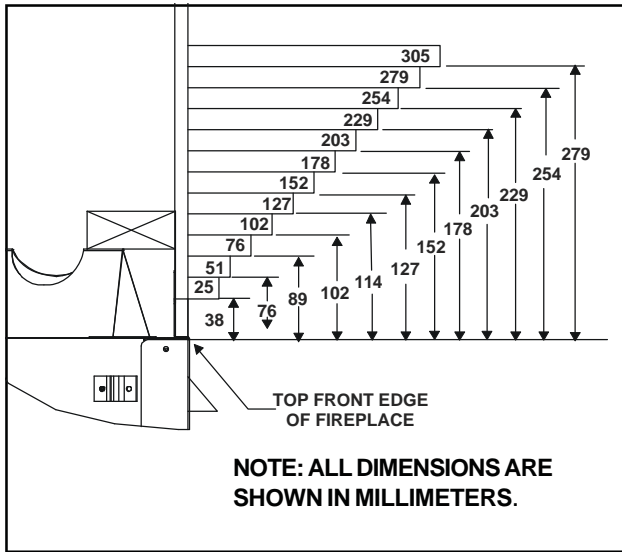

FIGURE 24.

1.6 MANTEL CLEARANCES

Clearance to a mantelpiece is 12-inches (305mm). See Figure 25.



◆ FIGURE 25.

IF JOINTS BETWEEN THE FINISHED WALLS AND THE FIREPLACE SURROUND (TOP AND SIDES) ARE SEALED, A 150° C. MINIMUM SEALANT MATERIAL MUST BE USED. THESE JOINTS ARE NOT REQUIRED TO BE SEALED. ONLY NON-COMBUSTIBLE MATERIAL (USING 150° C. MINIMUM ADHESIVE, IF NEEDED) CAN BE APPLIED AS FACING TO THE FIREPLACE SURROUND. SEE FIGURE 26.

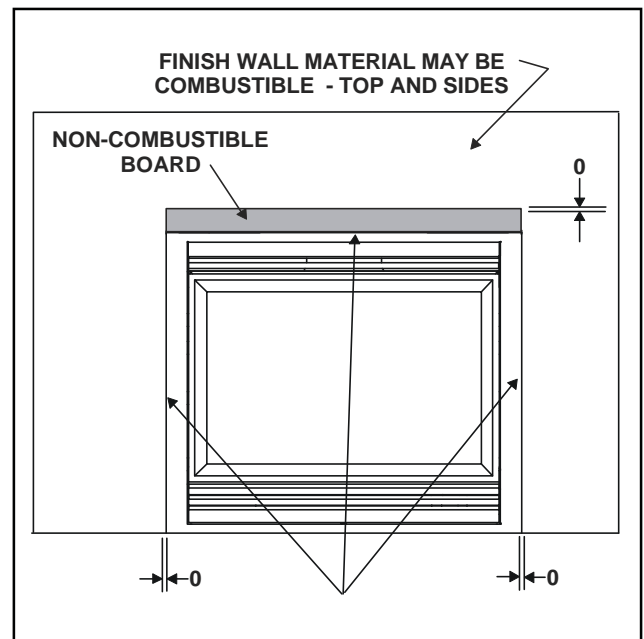

◆ FIGURE 26.

1.7 LOG PLACEMENT INSTRUCTIONS

Log Assembly: LOG-6TRS-AU

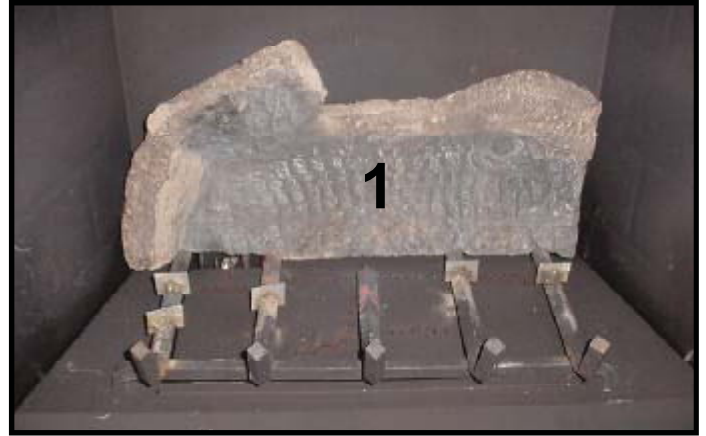

Carefully remove the logs from the packaging. **CAUTION:** Logs are fragile!

LOG #1 (SRV382-701): Locate log #1 on grate with notches and push log towards rear of firebox.

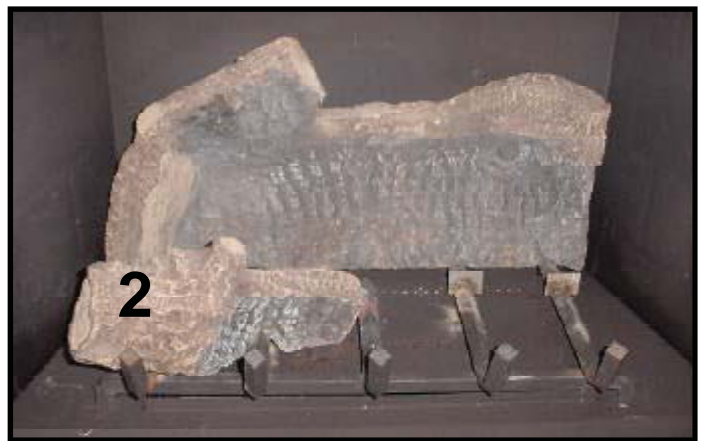
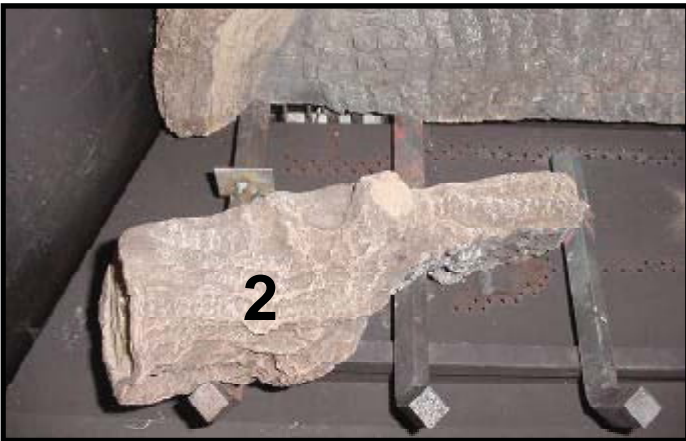

LOG #2 (SRV382-702): Locate log #2 on grate with notches. Slide left end of log forward and right side back against tab.

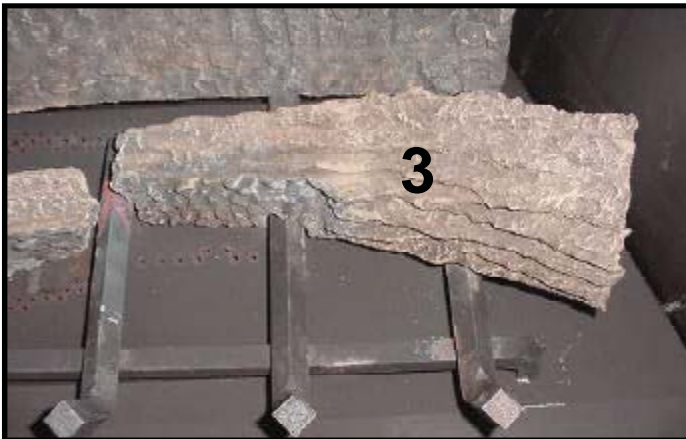

LOG #3 (SRV382-703): Locate log #3 on grate with notches. Slide back against the tabs.

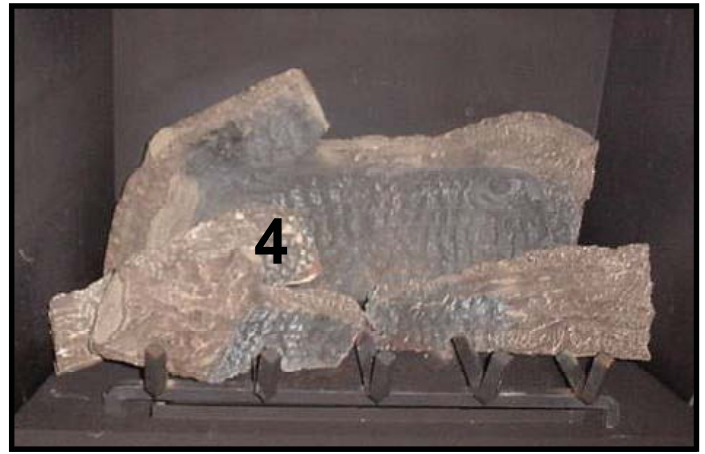

LOG #4 (SRV675-723): Place log #4 between log #2 and grate tab. Rest the right end on top of log #2.

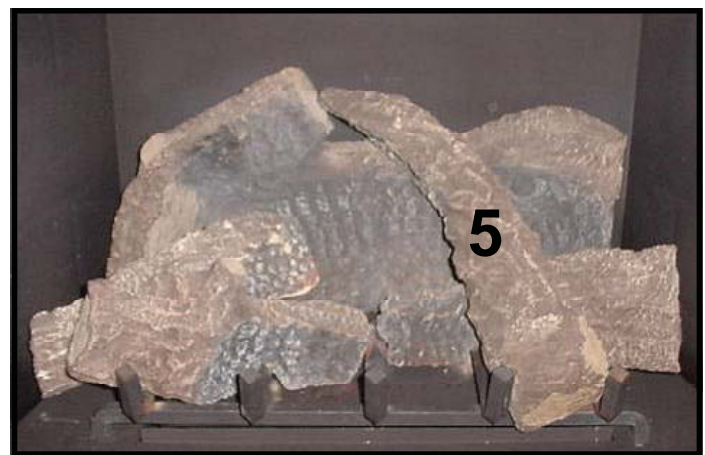
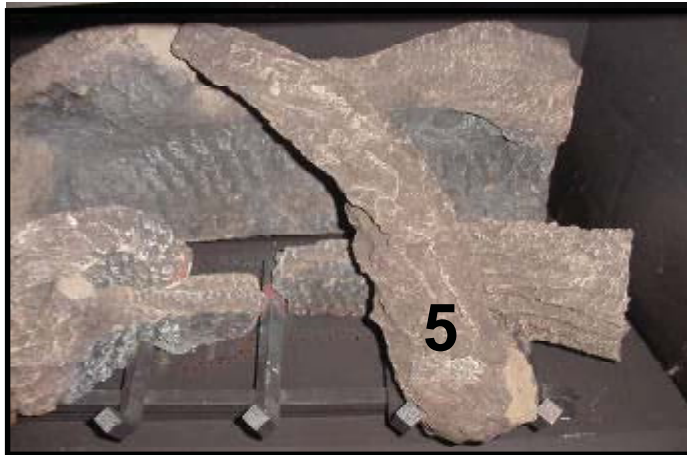

LOG #5 (SRV382-705): Place bottom of log #5 between the 4th and 5th grate bars rest the top onto log #1.

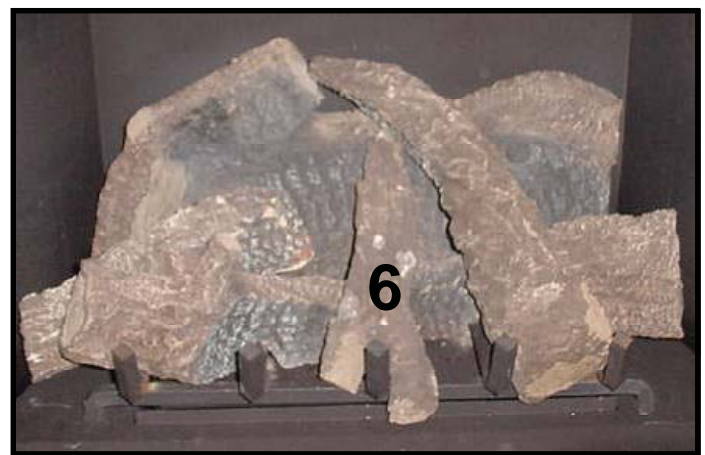
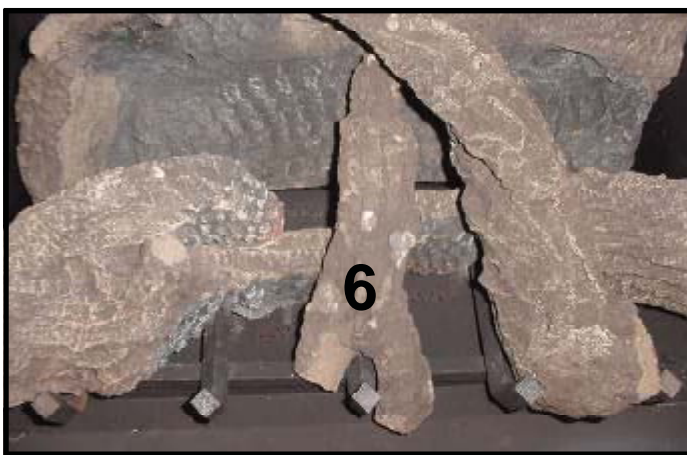

LOG #6 (SRV438-724): Place the "Y" shaped part of log #6 over the 3rd grate bar. Rest the tip of the log against log #1 and log #5.

1.8 INSTALLER TESTING

The space heater must be tested and be operating according to manufacturers specifications prior to the installer leaving the site. Note: the tips of the flames should never hit the top of the firebox after the unit has warmed up. Please contact your dealer or a qualified service person to replace injector or adjust valve.

Upon completing the gas line connection, a small amount of air will be in the lines. When first lighting the pilot light, it will take a few minutes for the lines to purge themselves of this air. Once the purging is complete, the pilot and burner will light and operate as indicated in the Lighting Instructions.

Subsequent lightings of the appliance will not require such purging.

CAUTION: DURING THE INITIAL PURGING AND SUBSEQUENT LIGHTINGS, NEVER ALLOW THE GAS VALVE CONTROL KNOB TO REMAIN DEPRESSED IN THE "PILOT" POSITION WITHOUT PUSHING THE RED IGNITOR BUTTON AT LEAST ONCE EVERY SECOND.

Follow the Safety Information and Lighting Instructions pages of this manual to light the appliance.

To obtain proper operation, it is imperative that the pilot and main burner flame characteristics are steady, not lifting or floating. Typically, the top 3/8-inch (9.5mm) at the pilot generator should be engulfed in the pilot flame. (Figure 27.)

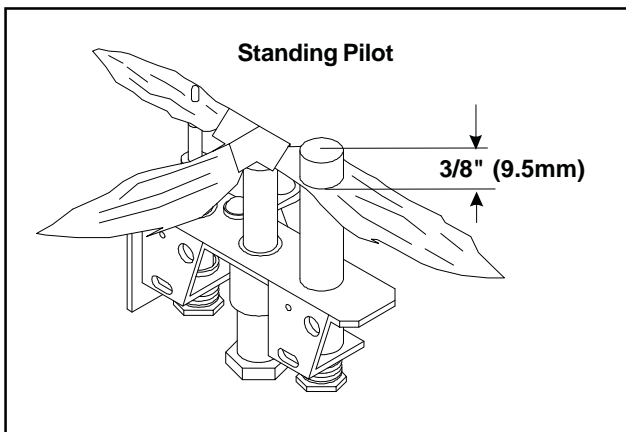

FIGURE 27.

Burner flame patterns are shown in Figure 28.

Follow Section 3.5 TROUBLESHOOTING for adjusting the appliance to operate properly.

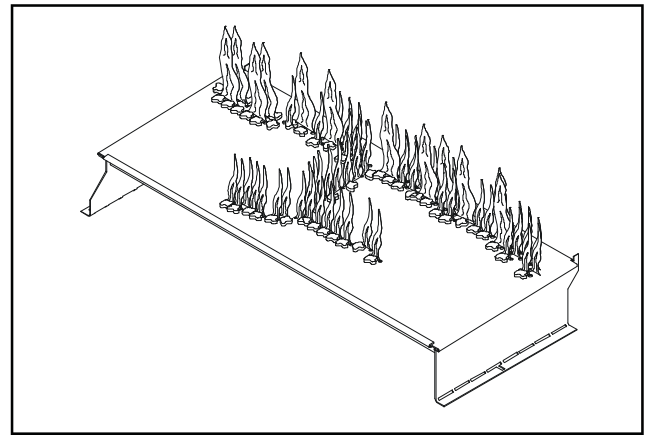

FIGURE 28.

2.0 OPERATING INSTRUCTIONS

This appliance is a balanced flue heater and is designed to operate with all combustion air being siphoned from the outside of the building and all exhaust gases expelled to the outside of the building.

WARNING: THIS UNIT IS NOT FOR USE WITH SOLID FUEL.

The control system for this model is a millivolt type. It consists of a gas control valve/variable regulator, a standing pilot assembly, a thermopile/thermocouple assembly, a piezo ignitor, an ON/OFF rocker switch and a safety high temperature limit switch. The controls are located in the lower compartment behind the lower door, and access is gained by lifting the door up. See Figure 1.

WARNING: DO NOT CONNECT 220-240 VAC TO THE GAS CONTROL VALVE OR CONTROL WIRING SYSTEM OF THIS UNIT.

The gas control system is wired so the thermopile, when heated with the pilot light, will provide approximately 350 to 500 millivolts. This activates the gas control valve. See Figure 29 for appliance wiring diagram.

Additionally, a high temperature limit switch is wired to ground and will shut-off the pilot and burner should a high surface temperature condition occur. The pilot and main burner must be re-lit when the heater cools. See Figure 29.

When lit for the first time, the appliance will emit a slight odor for an hour or two. This is due to paint and lubricants used in the manufacturing process. Additionally, for the first few minutes after each lighting, vapor may condense and fog the glass and the flames may be blue. After a few minutes this moisture will disappear and within 15-30 minutes the flames should become yellow.

The heater may produce a noise, caused from metal expansion and contraction as it heats up and cools down. This noise is similar to one that a furnace or heat duct may produce and does not affect the operation or longevity of the heater.

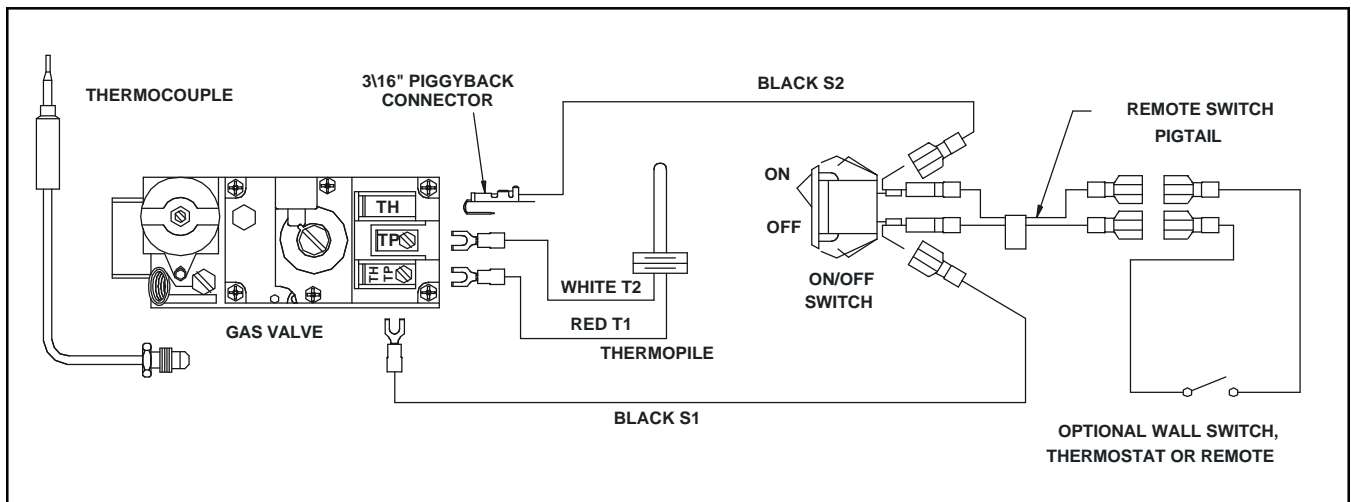

FIGURE 29.

OPERATING CAUTIONS

- THIS APPLIANCE MAY EXHIBIT A SLIGHT CARBON DEPOSITION.
- DO NOT PLACE ARTICLES ON OR AGAINST THIS APPLIANCE.
- DO NOT USE OR STORE FLAMMABLE MATERIALS NEAR THIS APPLIANCE.
- DO NOT SPRAY AEROSOLS IN THE VICINITY OF THIS APPLIANCE WHILE IT IS IN OPERATION.
- THE DRESS GUARD IS FITTED TO THIS APPLIANCE TO REDUCE THE RISK OF FIRE OR INJURY FROM BURNS AND NO PART OF IT SHOULD BE PERMANENTLY REMOVED FOR PROTECTION OF YOUNG CHILDREN OR THE INFIRM, A SECONDARY GUARD IS REQUIRED.
- THE DRESS GUARD MUST BE IN PLACE AND SEALED AND THE FIXED MESH TRIM ASSEMBLY MUST BE IN PLACE ON THE HEATER BEFORE THE UNIT CAN BE PLACED INTO SAFE OPERATION.
- DO NOT USE THIS APPLIANCE IF ANY PART HAS BEEN UNDER WATER. IMMEDIATELY CALL A QUALIFIED SERVICE TECHNICIAN TO INSPECT THE UNIT AND TO REPLACE ANY PART OF THE CONTROL SYSTEM AND ANY GAS CONTROL WHICH HAS BEEN UNDERWATER.
- DO NOT OPERATE THIS APPLIANCE WITH THE GLASS DOOR REMOVED, CRACKED, OR BROKEN. REPLACEMENT OF THE GLASS DOOR SHOULD BE DONE BY A LICENSED OR QUALIFIED PERSON. DO NOT STRIKE OR SLAM THE GLASS DOOR.
- THE GLASS DOOR ASSEMBLY SHALL ONLY BE REPLACED AS A COMPLETE UNIT AS SUPPLIED BY THE GAS HEATER MANUFACTURER. NO SUBSTITUTE MATERIALS MAY BE USED.

2.1 SAFETY & LIGHTING INFORMATION

Follow Section 2.2 SAFETY INFORMATION and 2.3 LIGHTING INSTRUCTIONS to light the appliance.

By design, the flame pattern will not be identical from unit to unit. Additionally, flame pattern may vary depending on installation type and weather conditions.

After the unit has warmed up (i.e. approximately 15 minutes) flame height should be slightly (about 2" (51mm) below the top of the mesh trim assembly. If the flame height is higher than this, adjustments must be made to prevent overheating the gasket and glass. Please

contact your dealer or a qualified service person to replace the injector or adjust the valve.

NOTE: THE TIPS OF THE FLAMES SHOULD NEVER HIT THE TOP OF THE FIREBOX.

These gas models have gas control valves which allows you to increase or decrease the height of the main burner flames. The control valves have pressure regulators with knobs. Rotate the knobs clockwise to "HI" to increase the flame height and counterclockwise to "LO" to decrease the flame height.

2.2 SAFETY INFORMATION

FOR YOUR SAFETY READ BEFORE LIGHTING

WARNING: IF YOU DO NOT FOLLOW THESE INSTRUCTIONS EXACTLY, A FIRE OR EXPLOSION MAY RESULT CAUSING PROPERTY DAMAGE, PERSONAL INJURY, OR LOSS OF LIFE.

- A. This appliance has a pilot. When lighting the pilot, follow these instructions exactly.
- B. BEFORE LIGHTING smell all around the appliance area for gas. Be sure to smell next to the floor because some gas is heavier than air and will settle on the floor.
- C. Use only your hand to push in or turn the gas control knob. Never use tools. If the knob will not push in or turn by hand, don't try to repair it. Call a qualified service technician. Forced or attempted repair may result in a fire or explosion.
- D. Do not use this appliance if any part has been under water. Immediately call a qualified service technician to inspect the appliance and to replace any part of the gas control system which has been under water.

WHAT TO DO IF YOU SMELL GAS

- Do not try to light any appliance.
- Do not touch any electric switch; do not use any phone in your building.
- Immediately call your gas supplier from a neighbor's phone. Follow the gas supplier's instructions.

2.3 LIGHTING INSTRUCTIONS

LIGHTING INSTRUCTIONS

1. "STOP!" Read the safety information on previous page.
2. To access controls, rotate the bottom grille down.
3. Turn the valve control knob to the "OFF" position. To do this, you must turn the knob clockwise to the "Pilot" position, and then press in and continue turning clockwise to the "OFF" position.

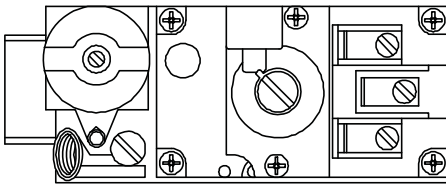

GAS CONTROL VALVE

NOTE: Knob cannot be turned from "PILOT" to "OFF" unless knob is pushed in slightly. Do not force.

4. WAIT FIVE (5) MINUTES TO CLEAR OUT ANY GAS. Then smell for gas, including near the floor. If you then smell gas, STOP! Follow "B" in the safety information above. If you don't smell gas, go to the next step.
5. The pilot should not require accessing for lighting purposes. The pilot is located inside the combustion chamber.

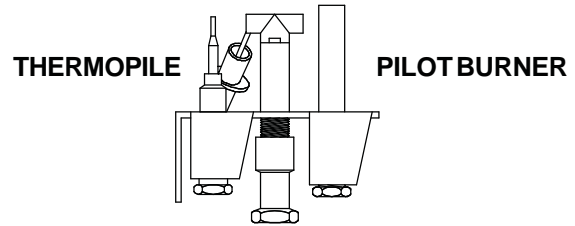

6. To put the control in the pilot position, turn the control knob counter-clockwise to the "Pilot" position.
7. To light the pilot depress the control knob and then depress the red or black piezo button until it makes a clicking sound. It may be necessary to repeat this step. If the pilot does not light after 10 seconds, go back to step 3. The control knob should be held down for a MINUTE after pilot ignition.
 - If the control knob does not pop out when released, **STOP**-shut off the gas supply to the heater control valve, and **IMMEDIATELY** call your service technician or gas supplier.
 - If the pilot will not stay lit after two tries, turn the control knob to the "OFF" position and call your service technician or gas supplier.
8. After the pilot has been lit, the burner can be turned on by turning the knob counter-clockwise to the "ON" position. Flip the ON/OFF switch to the "ON" position.
9. Close the bottom grille.
10. When using accessories leave rocker switch in the "OFF" position.

TO TURN OFF GAS APPLIANCE

1. Open the bottom grille.
2. Turn ON/OFF switch to "OFF".
3. Turn the valve control knob clockwise to the "Pilot" position, then depress knob and continue turning to "OFF" position.
4. Close the bottom grille.

2.4 FAN OPERATION

The accessory fan is wired in series with a speed control switch and a temperature sensor switch. Set the speed control to an "ON" position and light the heater. The temperature sensor switch will automatically start the fan when the switch warms up—and stop the fan when it cools down. You can manually stop the fan by turning the speed control switch to "OFF". See Figure 19 for fan wiring diagram.

3.0 SERVICING AND MAINTENANCE

- A. **HEATER SERVICING:** Frequency of heater servicing will depend upon use and type of installation.
- B. **IMPORTANT:** TURN OFF GAS BEFORE SERVICING APPLIANCE. IT IS RECOMMENDED THAT A COMPETENT SERVICE TECHNICIAN PERFORM SERVICE CHECK-UPS AT THE BEGINNING OF EACH HEATING SEASON.
- C. The appliance and flue system should be inspected before initial use and at least annually by a qualified field service person.
- D. Inspect the external flue cap on a regular basis to make sure that no debris is interfering with the air flow.
- E. Keep the control compartment, logs, and burner area surrounding the logs clean by vacuuming or brushing at least twice a year.

CAUTION: THE LOGS GET VERY HOT - HANDLE ONLY WHEN COOL.

WARNING: DO NOT USE ABRASIVE CLEANERS ON THE GLASS DOOR ASSEMBLY. DO NOT ATTEMPT TO CLEAN THE GLASS DOOR WHEN IT IS HOT.

- F. The glass door should be cleaned using a household glass cleaner. **DO NOT** handle or attempt to clean the glass when it is **HOT**.
- G. In order to properly clean the burner and pilot assembly, turn off the gas to the unit and remove the logs exposing the burner and pilot assembly. Clean all foreign materials from top of burner. Check to make sure that the burner orifice is clean.

Visually inspect the pilot periodically. Brush or blow away any dust or linen accumulations. If the pilot orifice is plugged, disassembly may be required to remove any foreign materials from the orifice or tubing. When the appliance is put back in service check burner flame patterns with Figure 30.

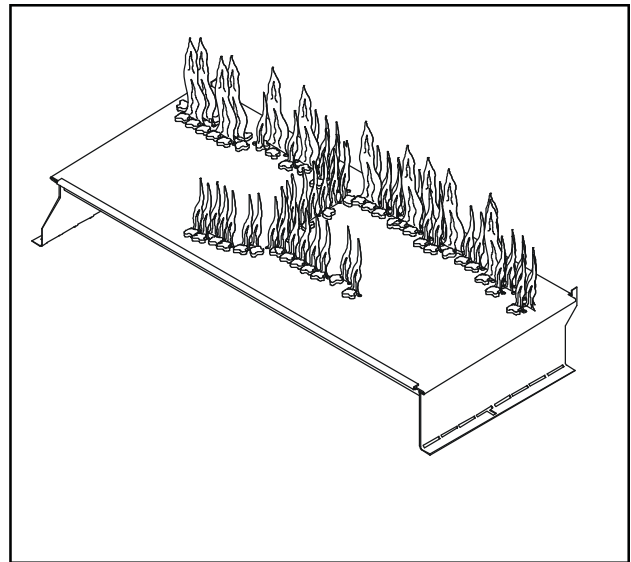

FIGURE 30.

To obtain proper operation, it is imperative that the pilot and main burner flame characteristics are steady, not lifting or floating. Typically, the top 3/8-inch at the pilot generator should be engulfed in the pilot flame (Figure 31).

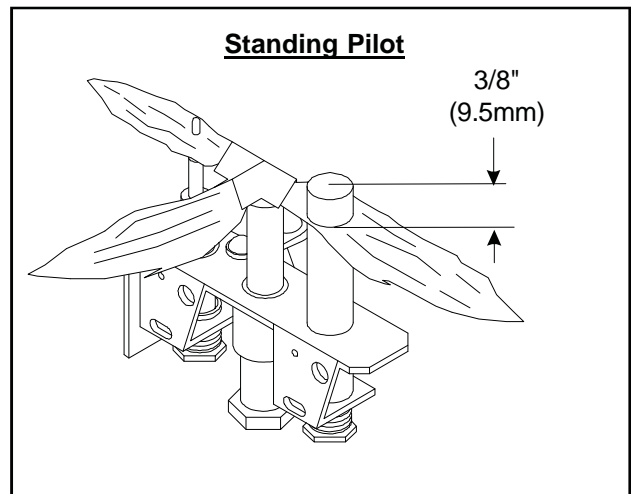

FIGURE 31.

3.1 REMOVAL OF COVERS FOR SERVICING

A. Control Compartment Grille

- Lift the lower door up and out to access the gas controls.

B. Trim door and Glass Door

- Lift the front trim door up and out away from the appliance side surrounds. Replace the door when servicing is complete.
- Noting carefully how the brackets fit on the glass, release the two spring latches at the top and two at the bottom of the glass door. Carefully lift the glass up and out away from the appliance. See Figure 32.

3.2 REMOVAL OF COMPONENTS FOR SERVICE

1. BURNER

- Remove the front refractory bracket and carefully lift up and remove the log set/log grate/refractory assembly.
- Unscrew the brackets at both ends of the burner and slide the burner away from the burner orifice.

2. PILOT ASSEMBLY/IGNITION SYSTEM

- Remove the log set/log grate/refractory assembly.
- Disconnect the gas supply tube from the underside of the pilot burner.

- Disconnect the electrode wire from the piezo ignitor (found adjacent to the gas control valve).
- Disconnect the attachment nut from the underside of the thermopile. The thermopile can then be separated from the pilot bracket.
- Unscrew the pilot assembly bracket and remove. **NOTE:** When removing the pilot assembly, carefully pull the electrode wire up through the grommeted hole in the base pan.

3.3 PARTS REPLACEMENT

1. FAN/SWITCHES

- Unplug the fan wires from the junction box wires by pulling the male and female connectors apart and slide the fan out the front of the lower controls compartment.
- Disconnect the wires from the fan speed control switch, pull off the knob, and remove the nut holding the speed control to the bracket.
- Disconnect the wires from the fan temperature sensor switch and remove the nut holding the switch bracket onto the bottom of the firebox.

2. GLASS PANEL

- To replace the glass door, place the bottom edge into the lower holders, push glass against unit and secure the two spring latches at the top and bottom.

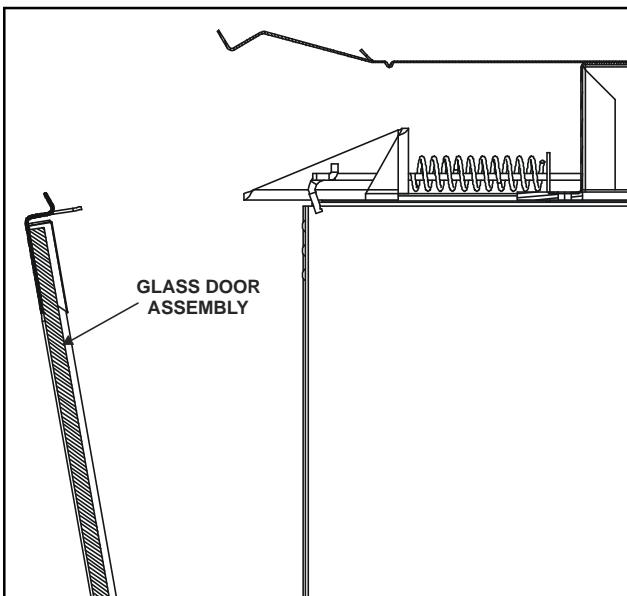

FIGURE 32.

3.4 ADJUSTMENTS AND REPLACEMENT PARTS

Adjustments and replacement parts for this appliance should only be done by a qualified service person. A wiring diagram for the appliance is shown in **SECTION 2.0 OPERATING INSTRUCTIONS**. A replacement part table is shown in **SECTION 4.0** of this manual.

3.5 TROUBLESHOOTING - 6000TRS-AU

With proper installation and maintenance, your new Gas Fireplace should provide years of trouble-free service. If you do experience a problem, refer to the Troubleshooting Guide below. This guide will assist a qualified service person in the diagnosis of problems and the corrective action to be taken.

SYMPTOM	POSSIBLE CAUSE	CORRECTIVE ACTION
I. Spark Ignitor will not light pilot after repeated triggering of red or black button.	A. Defective ignitor (no spark at electrode).	1. Check for spark at electrode and pilot; if no spark and electrode wire is properly connected, replace ignitor.
	B. Defective pilot or misaligned electrode (spark at electrode).	1. Using a match, light pilot. If pilot lights, turn off pilot and trigger the red or black button again. If pilot lights, an improper gas/air mixture caused the bad lighting and a longer purge period is recommended. If pilot will not light - check gas at electrode and pilot - should be 1/8 inch (3.2mm) to have a strong spark. If OK, replace pilot.
	C. No gas or low gas pressure.	1. Check unit's shut-off valve and remote shut off valves from heater. Usually there is a valve near the main. There can be more than one (1) valve between the heater and main.
	D. No L.P. in tank.	2. Low pressure can be caused by a variety of situations such as a bent line, too narrow diameter of pipe or even low line pressure. Check for kinked lines. If none, consult with plumber or gas supplier. 3. Check L.P. (propane) tank. You may be out of fuel.
II. Pilot will not stay lit after carefully following lighting instructions.	A. Defective thermocouple.	1. Check pilot flame. Must impinge on thermocouple. Clean and or adjust pilot for maximum flame impingement on thermocouple. 2. Be sure wire connections from thermocouple at gas valve terminals are tight and thermopile is fully inserted into pilot bracket.

SYMPTOM	POSSIBLE CAUSE	CORRECTIVE ACTION
<p>III. Pilot burning, no gas burner, valve knob "ON", "on-off" switch "ON".</p>	<p>A. "ON-OFF" switch or wires defective.</p>	<p>3. Check thermopile with millivolt meter. Take reading at "TH-TP&TP" terminals of gas valve. Should read 325 millivolts minimum while holding valve knob depressed in pilot position, pilot lit, and on/off switch "OFF". Replace faulty thermocouple if reading is below specified minimum.</p> <p>4. Disconnect thermopile leads from the valve. With pilot burner "ON", take reading at thermopile leads - should read 325 millivolts minimum. Replace thermopile if reading is below this minimum.</p> <p>1. Check wire continuity and connection in pilot circuit.</p> <p>1. Disconnect the thermopile's red wire from the micro-switch and connect to terminal "TP" on the gas valve. Turn green knob to pilot position, depress and light pilot light. If meter reading is greater than 325 m.v. after 30 seconds, the pilot generator is good. If pilot does not stay lit, the valve is defective. If the meter reading is less than 325 m.v., the thermopile is defective.</p> <p>1. Check "on-off" switch and wires for proper connections. Place jumper wires across terminals at switch-if burner comes on, replace defective switch. If OK, place jumper wires across switch wires at gas valve-if burner comes on, wires are faulty or connections are bad.</p>
	<p>B. Open wire connection in pilot circuit.</p>	
	<p>C. Defective valve.</p>	
	<p>B. Thermopile may not be generating sufficient milli-voltage. (325m.v.)</p>	<p>1. Recheck Symptom #2.</p> <p>2. Pilot flame not physically close enough to thermopile.</p>

SYMPTOM	POSSIBLE CAUSE	CORRECTIVE ACTION
	C. Defective valve.	1. Turn valve knob to "ON". Place ON/OFF switch to "ON". Check with millivolt meter at thermopile terminals. Millivolt meter should read greater than 100 m.v. If the reading is okay and the burner does not come on, replace the gas valve.
	D. Plugged burner orifice.	1. Check burner orifice for stoppage and remove.
	E. Wall switch or wires defective.	1. Follow corrective action in A.1 above; check switch and wiring. Replace where defective.
IV. Frequent pilot outage problem.	A. Pilot flame may be too low or blowing (high), causing the pilot safety to drop out.	1. Clean and adjust pilot flame for maximum flame impingement on thermopile.
V. Pilot and main burner go out while being in operation.	A. High limit switch is defective or has reached its maximum temperature.	<p>1. Allow unit to cool. Then repeat lighting instructions. If pilot and burner remain lit after the heater warms up, the switch is good.</p> <p>2. If 1 above does not allow for ignition, or the heater continues to shut-off, disconnect the limit switch wire from the gas valve and repeat the lighting instructions. If the pilot and burner remain lit after the heater warms up, replace the limit switch. Do not use the heater until the high limit switch is replaced and properly wired.</p>
	B. No L.P. in tank.	1. Check L.P. (Propane) tank. You may be out of fuel.
	C. Inner 5-inch (13mm) pipe leaking exhaust gases back into system.	1. Check for leaks.
	D. Horizontal flue improperly pitched.	1. Horizontal flue termination should slope down only enough to prevent water from entering unit. The maximum downward slope is 1/4" (6.4mm) for any horizontal run.

SYMPTOM	POSSIBLE CAUSE	CORRECTIVE ACTION
VI. Glass soots.	E. Glass too loose and air tight gasket leaks in corners after usage.	1. Tighten corner.
	F. Bad thermopile	1. Replace if necessary.
	G. Improper flue cap installation.	1. Check for proper installation & freedom from debris or blockage.
VI. Glass soots.	A. Flame impingement on logs.	1. Adjust the log set so that the flame does not impinge on it.
	B. Improper venturi setting.	1. Adjust the air shutter at the base of the burner.
	C. Debris around venturi.	1. Inspect the opening at the base of the burner. It is imperative that <u>NO</u> material be placed in this opening.
VII. Flame burns blue and lifts off burner.	A. Insufficient oxygen being supplied.	<p>1. Check to make sure flue cap is installed properly and free of debris. Make sure that flue system joints are tight and have no leaks.</p> <p>2. Check to make sure that no material has been placed in the opening at the burner base or in the area of the air holes in the center of the base pan beneath the burner.</p> <p>3. Be sure glass is tightened properly on unit, particularly on top corners.</p>

LIMITED 10 YEAR WARRANTY
HEAT-N-GLO, a division of Hearth Technologies Inc.

In order to presumptively establish the dates to which your HEAT-N-GLO Limited 10 Year Warranty runs, you must mail the completed warranty card to HEAT-N-GLO, a division of Hearth Technologies Inc., 20802 Kensington Boulevard, Lakeville, MN 55044, within 60 days of the date of fireplace installation. If you fail to do so, you may be required to prove the date of installation before warranty work can be performed.

The warranty exclusions and limitations of liability are effective upon installation of the fireplace.

Subject to the conditions set forth herein, HEAT-N-GLO, a division of Hearth Technologies Inc. ("HEAT-N-GLO") extends the following warranty with respect to HEAT-N-GLO, a division of Hearth Technologies Inc..

If HEAT-N-GLO is reasonably satisfied that any part or portion of the fireplace covered by this Limited Warranty is defective in material or workmanship under normal use and service as described in the Operating Instructions, HEAT-N-GLO will take the following actions:

1. If the defect is reported during the first year from the date of installation (stainless steel burners and fiber logs are covered for 3 years), HEAT-N-GLO will replace or repair the defective components at its sole expense. The decision whether to replace a component shall be made at HEAT-N-GLO's sole discretion. This Limited Warranty does not cover components broken during shipping, misuse or careless handling. HEAT-N-GLO shall be not responsible for any indirect, incidental, or consequential damages or for any costs other than those incurred by HEAT-N-GLO to repair or replace the defective component. If components (including venting) other than factory approved components are used, all warranty and liability on the fireplace is voided. **Defects reported after the first year will not be covered by warranty unless they fall within the purview of paragraph 2 or 3 below.**
2. If the following defects are reported during the second year after the date of installation, HEAT-N-GLO will supply replacement parts at the current wholesale price: defective electrical or manual components, optional components or accessories, and glass panels (not including glass panels broken during misuse or careless handling). HEAT-N-GLO shall not be responsible for any labor, transportation or other costs. Furthermore, it shall not be liable for any indirect, incidental or consequential damages.
3. HEAT-N-GLO will replace or repair a defective firebox or heat exchanger, at any time during the 10 years from the date of installation. The decision whether to replace the defective component shall be made at HEAT-N-GLO's sole discretion. HEAT-N-GLO shall not be responsible for any indirect, incidental or consequential damages or for any costs other than those incurred by HEAT-N-GLO to repair or replace the defective component.

This Limited Warranty is the exclusive remedy available to you. If HEAT-N-GLO cannot effectively resolve a warranty problem in an expedient and cost-effective manner, it can discharge its entire warranty liability by refunding the price of the product to you.

Products made by other manufacturers, whether sold with the fireplace or added thereafter, are NOT covered by this Limited Warranty. The use of other unauthorized components will make this warranty null and void. This Limited Warranty will also be void if the appliance is not installed by a qualified installer in accordance with the Installation Instructions. Furthermore, the Limited Warranty will be void if the fireplace is not operated, at all times, according to the Operating Instructions furnished with the fireplace. Any service work must be performed by authorized service representatives.

EXCEPT TO THE EXTENT PROVIDED BY LAW, NO OTHER EXPRESS OR IMPLIED WARRANTIES, INCLUDING WARRANTIES OF MERCHANTABILITY OR FITNESS FOR A PARTICULAR PURPOSE, SHALL APPLY TO THE FIREPLACE PRODUCT. In States that do not allow limitations on how long an implied warranty lasts, or do not allow exclusion of indirect damages, those limitations or exclusions may not apply to you. You may also have additional rights not covered in this Limited Warranty.

HEAT-N-GLO reserves the right to make changes at any time, without notice, in design, material, specifications and prices. It also reserves the right to discontinue styles and products.