

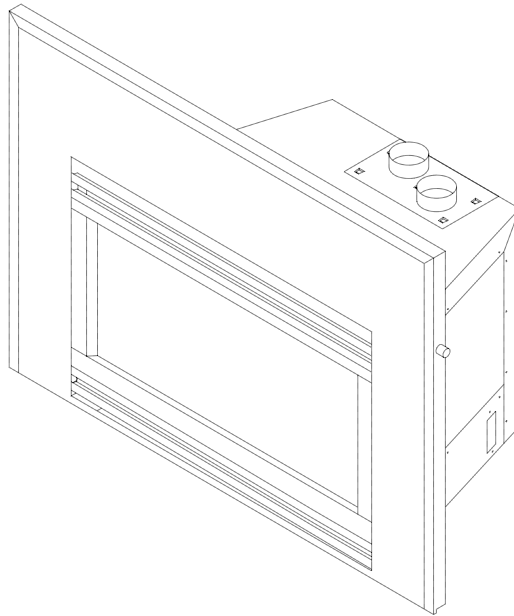

## INSTALLATION AND OPERATION INSTRUCTIONS



### **MODEL: ATS-AUST**

AUSTRALIAN GAS ASSOCIATION APPROVED

AGA Approval Number 5543

**THIS MANUAL MUST BE USED FOR INSTALLATION AND RETAINED  
BY HOMEOWNER FOR OPERATION AND MAINTENANCE.**

**HEAT-N-GLO, a division of Hearth Technologies Inc.**

6665 W. Hwy 13 Savage, MN 55378, USA (612)890-8367

This product is covered by one or more of the following patents: (United States) 4,112,913; 4,408,594; 4,422,426; 4,424,792; 4,520,791; 4,793,322; 4,852,548; 4,875,464; 5,000,162; 5,016,609; 5,076,254 5,191,877; 5,218,953; 5,328,356; 5,429,495; 5,452,708; 5,542,407; 5,613,487; (Australia) 543790; 586383; (Canada) 1,123,296; 1,297,746; 2,195,264; (Mexico) 97-0457; (New Zealand) 200265; or other U.S. and foreign patents pending.



## **INSTALLATION AND OPERATION INSTRUCTIONS**

**PLEASE READ THIS MANUAL BEFORE INSTALLING AND USING THIS APPLIANCE.**

**MODEL ATS-AUST IS AUSTRALIAN GAS ASSOCIATION APPROVED FOR NATURAL GAS OR PROPANE AS A BALANCED FLUE HEATER.**

Refer to the appliance data plates for gas consumptions and pressures.

Installation of this appliance should only be carried out by an authorized person in accordance with the manufacturers instructions. All relevant codes and regulations laid down by the gas piping authorities, municipal building regulations, electrical wiring regulations and the requirements of the AGA Gas Installation Code must be observed.

This appliance and it's components are tested and safe when installed in accordance with this Installation Manual. Report to your dealer any parts damaged in shipment, specifically check glass condition. The gas logs and flue system components are in separate packages. Read all instructions before starting installation and follow these instructions carefully during installation to ensure maximum benefit and safety. Failure to follow them will void your warranty and may present a fire hazard.

The Heat-N-Glo Fireplace Products, Inc. warranty will be voided by, and Heat-N-Glo Fireplace Products, Inc. disclaims any responsibility for the following actions:

- Installation of any damaged heater or flue system component
- Modification of the heater or balanced flue system Installation other than as instructed by Heat-N-Glo Fireplace Products, Inc.
- Improper positioning of the gas logs or the glass door
- Installation and/or use of any component part not manufactured or approved by Heat-N-Glo Fireplace Products, Inc., notwithstanding any independent testing laboratory or other party approval of such component part or accessory.

**IMPORTANT:** Read all instructions carefully before starting installation. Failure to follow these installation instructions may result in a possible fire hazard and will void the warranty.

Save this Manual for future reference.

Copyright 1999, Heat-N-Glo Fireplace Products, Inc., 6665 W. Hwy 13, Savage, MN 55378 Printed in U.S.A.

## **TABLE OF CONTENTS**

1.0	Installation Instructions .....	7
1.1	Introduction .....	7
1.2	Flue System .....	7
1.2.1	Flue System Approvals .....	7
1.2.2	Connecting the Flue Pipe .....	8
1.3	Connecting the Gas Supply .....	8
1.4	Fan .....	9
1.5	Surround Installation .....	9
1.6	Finishing .....	11
1.7	Log Installation .....	11
1.8	Installer Testing .....	11
2.0	Operating Instructions .....	12
2.1	Safety and Lighting Information .....	13
2.2	Safety Information .....	13
2.3	Lighting Instructions .....	14
2.4	Fan Operation .....	15
3.0	Servicing and Maintenance .....	15
3.1	Removal of Covers for Servicing .....	16
3.2	Removal of Components for Service .....	16
3.3	Parts Replacement .....	16
3.4	Adjustments and Replacement Parts .....	16
3.5	Troubleshooting .....	17
4.0	Replacement Parts .....	21
	Limited Warranty .....	24

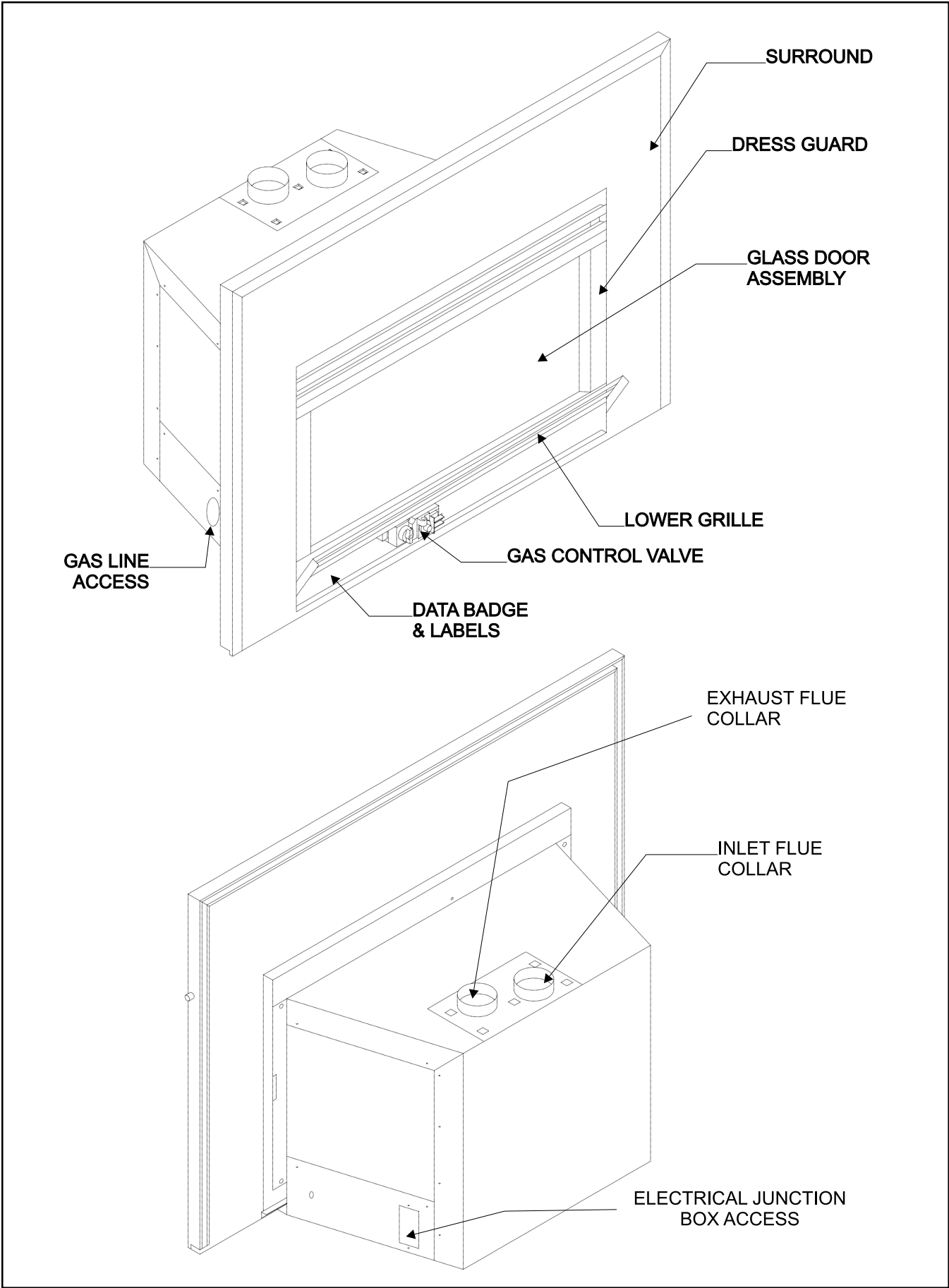
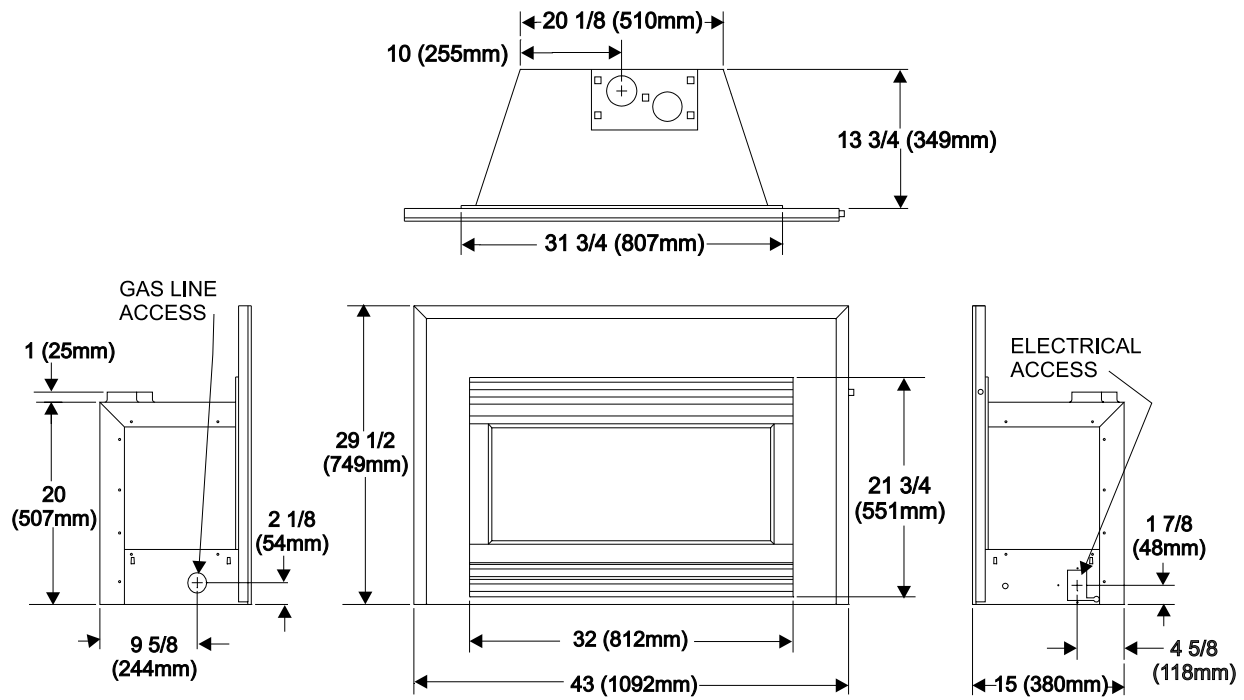
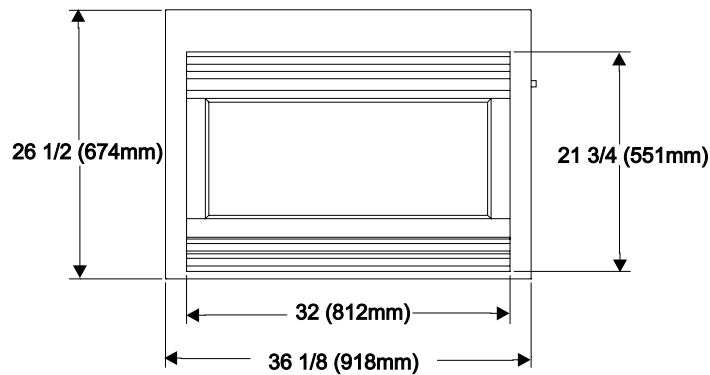

FIGURE 1



ATSA-4028



ATSA-3626

TOP VIEW  
MASONRY OF FACTORY-BUILT FIREPLACE

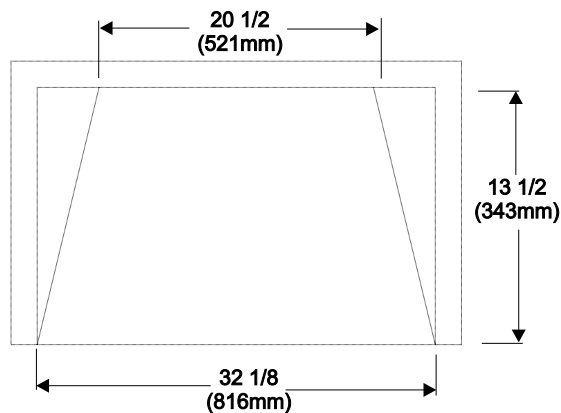

**MINIMUM FIREPLACE OPENING**

WIDTH:	32 1/8"	(816mm)
DEPTH:	13 1/2"	(343mm)
HEIGHT:	20 1/2"	(521mm)

**NOTE:** If exhaust collar on insert and fireplace damper do not line up, add 4 inches (102mm) to minimum fireplace opening height to accommodate bends in vent pipe.

FIGURE 2

**MODEL**

ATS-AUST

**FLUE TERMINATION APPROVAL**

SLK-991DA

VERTICAL TERMINATION CAP

**TABLE 1**

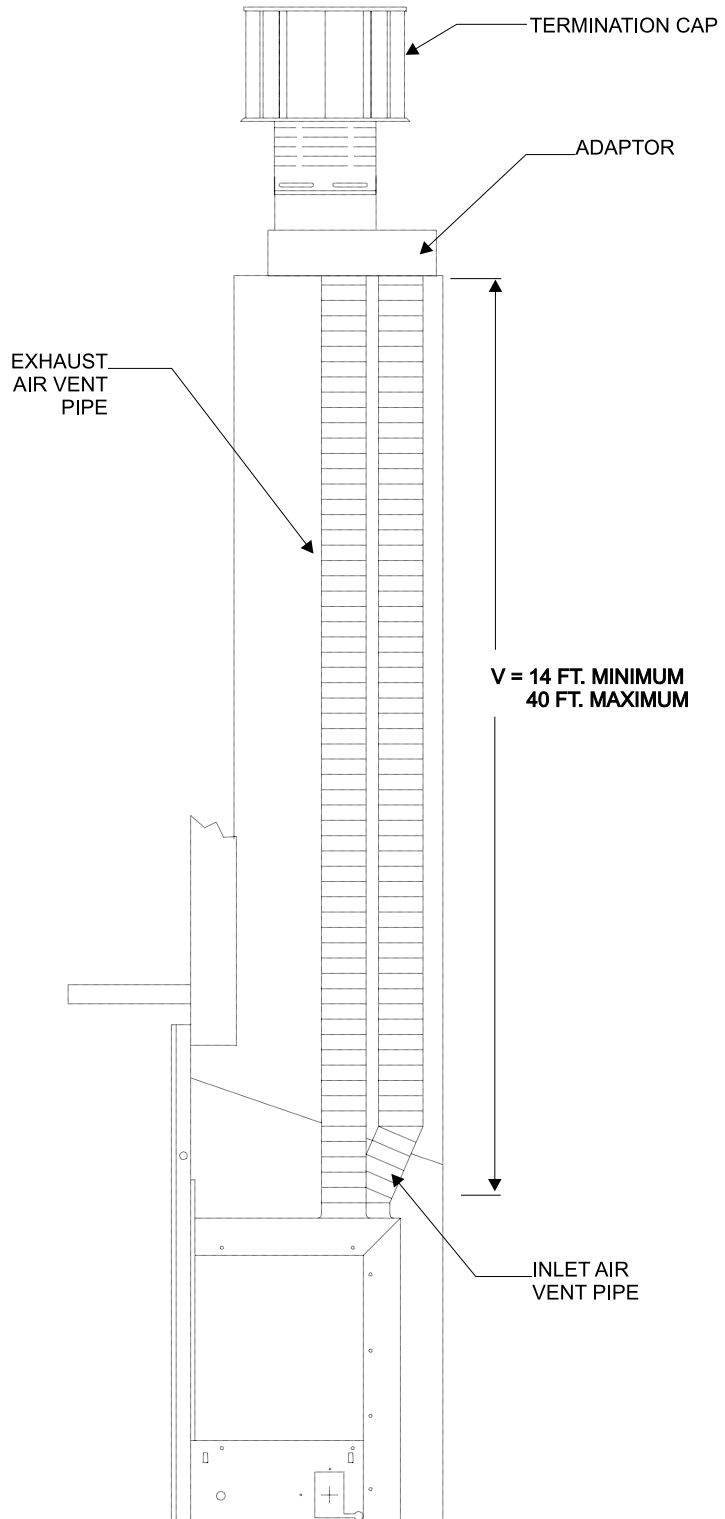

**WARNING:** THE EXHAUST PIPE MUST ONLY BE CONNECTED TO THE EXHAUST STARTING COLLAR OF THE UNIT AND THE CENTER COLLAR OF THE TERMINATION CAP.

THE INLET AIR PIPE MUST ONLY BE CONNECTED TO THE INLET AIR COLLAR OF THE UNIT AND ATTACHED TO THE INLET AIR COLLAR OF THE TERMINATION CAP.

**FIGURE 3**

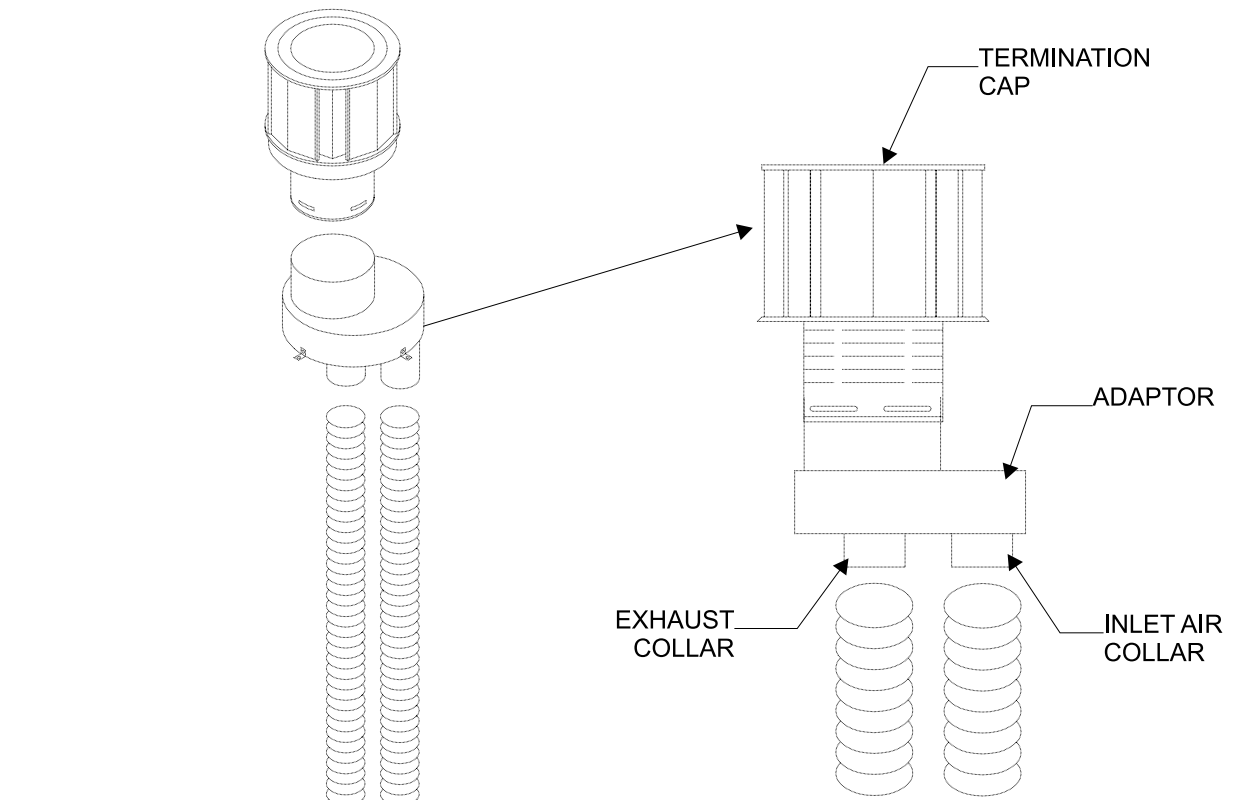

**FIGURE 4**

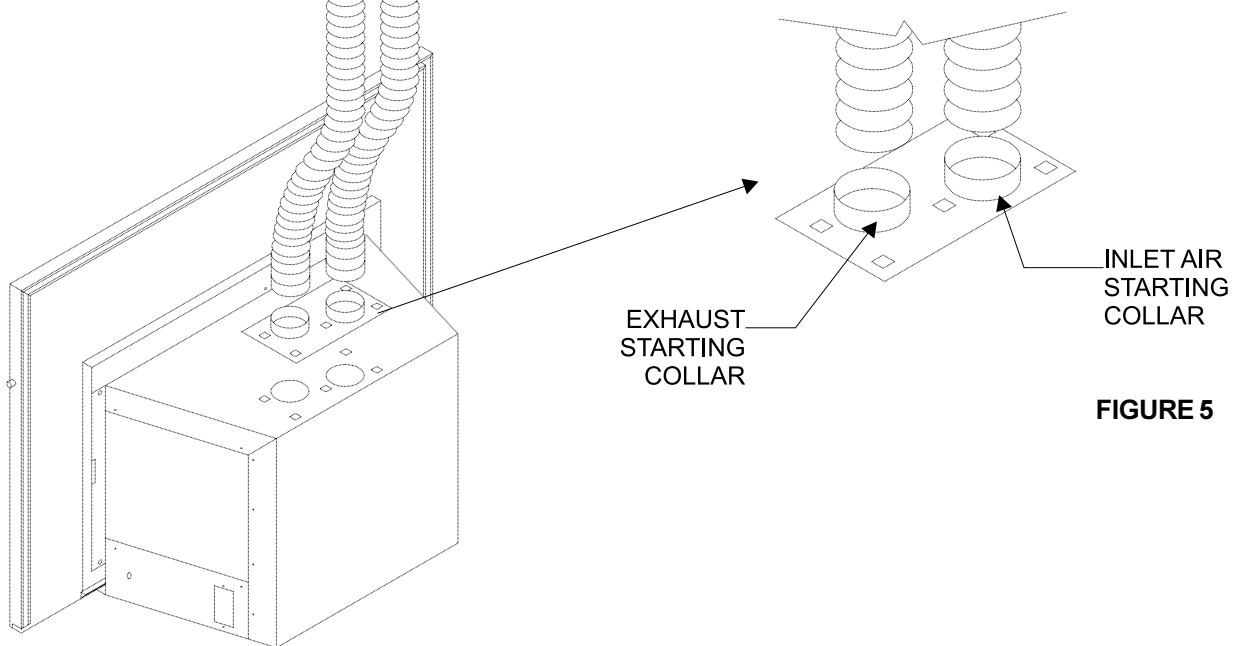

**FIGURE 5**

## 1.1 INTRODUCTION

This model is designed to operate with all combustion air being siphoned from the outside of the building and all exhaust gases expelled to the outside of the building. This model is designed to be installed in a masonry fireplace or factory built fireplace. These units **CANNOT** be recessed inside combustible construction.

Minimum dimensions of the masonry or factory-built fireplace into which these models can be installed, are 32 1/8-inches (816mm) width x 13 1/2 -inches (343mm) depth x 20 1/2 inches (521mm) height.

**WARNING: THIS UNIT IS NOT FOR USE WITH SOLID FUEL.**

These units **MUST** use the flue termination described in the flueing section of the manual.

The control system for these model are a millivolt type. It consists of a gas control valve/variable regulator, a standing pilot/thermopile/thermocouple, a piezo ignitor, and an ON/OFF switch. The controls are located behind the lower grille. Access to the controls is gained by rotating the grille up. ON/OFF switch is located on the front surround. See Figure 1.

Minimum inlet gas supply pressure for purpose of input adjustment is 4.5 inches w.c. (1.13kPa) for natural gas and 11 inches w.c. (2.75kPa) for propane. Manifold (outlet) pressures should be set at 3.2 inches w.c. (.80kPa) for natural gas models and 9.6 inches w.c. (2.40kPa) for propane models.

In planning the installation for the insert it is necessary to determine where the unit is to be installed, and whether optional accessories (wall switch, thermostat, or remote control) are desired. Gas supply piping should also be planned. Model ATS-AUST has a factory installed fan.

This model is designed to be installed in a masonry or factory-built fireplace. The separate 3-inch (76mm) combustion air and exhaust pipes must be run up through the chimney and terminated vertically. Horizontal flue terminations **MUST NOT** be done.

Before starting installation of flue kits, the installer should read the Gas Fireplace Instructions and the Flue Kit Instructions to ensure that a proper flue installation is completed.

Consult your local Building Codes before beginning the installation.

**WARNING: THIS GAS FIREPLACE AND FLUE ASSEMBLY MUST BE FLUED DIRECTLY TO THE OUTSIDE AND MUST NEVER BE ATTACHED TO A CHIMNEY SERVING A SEPARATE SOLID FUEL BURNING APPLIANCE. EACH GAS APPLIANCE MUST USE A SEPARATE FLUE SYSTEM.**

**CAUTION: Prior to connecting the flue system to the unit, read sections:**

1.3 Connecting the Gas Supply

1.4 Accessory Fan

## 1.2 FLUE SYSTEM

### 1.2.1 FLUE SYSTEM APPROVALS

Table 1 and Figures 3-5 show the flue termination caps and systems approved for use with these models. Approved flue system terminations are labeled for identification. 3-inch (76mm) diameter listed flexible aluminum or stainless steel gas flue is used for both the incoming combustion air and exhaust flue pipes. **NO OTHER FLUEING SYSTEMS OR COMPONENTS MAY BE USED.** Detailed installation instructions are included with each flue termination kit and should be used in conjunction with this manual.

### HORIZONTAL FLUEING

The flue system on this model **CANNOT** be terminated horizontally.

### VERTICAL FLUEING

The flue pipes **MUST** be connected to the proper collars on the unit **AND** the exhaust flue pipe **MUST** be connected to the termination cap or the unit will not operate. The combustion air flue pipe **MUST** be connected to the termination cap.

**NOTE:** The minimum vertical rise (exhaust flue) is 14 feet (3.5M) and the maximum vertical rise is 40 feet (10M). These dimensions are measured from the starting collars of the unit to the end of the last section of flue pipe (See dimension V in Figure 3).

A vertical flue termination system installed on this model will include one (1) length of 3-inch (76mm) flexible flue pipe for the combustion air, one (1) length of 3-inch (76mm) flexible flue pipe for the exhaust, one (1) pipe-to-cap adaptor, and one (1) SLK-991DA Vertical Termination Kit.



## 1.2.2 CONNECTING THE FLUE PIPE

**NOTE:** The damper of the masonry or factory-built chimney may have to be removed to allow installation of the flexible-flue pipe.

Install the 3-inch (76mm) flexible flue pipes down through the chimney. Remove the starting collar bracket from the top of the unit. See Figure 4. Attach and secure the bottom ends of the flex pipes to the starting collar bracket with 3 plated sheetmetal screws on each collar. Slide the gas insert into place, and position any excess flex flue pipe back up into the chimney. Re-attach the collar bracket to the unit. There are two end tabs bent down from the top of the unit into the fan air passageway. After the collar bracket is re-attached, bend the tabs upward using a long screwdriver or similar tool. The tabs will bend up behind the lances and hold the collar bracket from sliding backwards.

Attach the pipe-to-cap adaptor to the termination cap and to the top of the flexible flue pipe and set the cap in place at the top of the chimney. See Figures 4 and 5.

**CAUTION:** To avoid downdrafts and/or cold air problems, it is recommended to seal off the area between the termination cap and the top of the solid-fuel chimney opening into which the flue cap has been installed.

**WARNING:** A 12-inch (305mm) minimum chimney and/or flue height above the roof top is necessary in the interest of safety. See Figure 7.

**NOTE:** THIS ALSO PERTAINS TO VERTICAL FLUE SYSTEMS INSTALLED ON THE OUTSIDE OF THE BUILDING.

## 1.3 CONNECTING THE GAS SUPPLY

The gas is introduced to the appliance on the left hand side. See Figure 8. After the gas pipe installation is complete, check carefully all gas connections for leaks with a soap solution. DO NOT USE AN OPEN FLAME.

**NOTE:** THE GAS SUPPLY LINE SHOULD BE PURGED OF ANY TRAPPED AIR PRIOR TO THE FIRST FIRING OF THE UNIT.

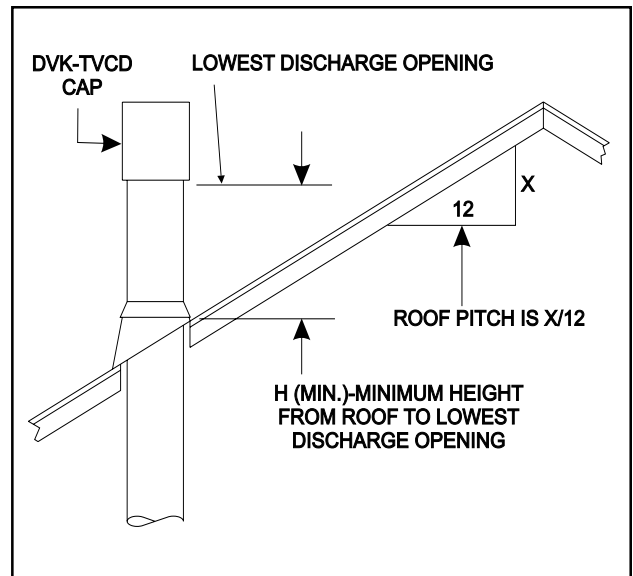

FIGURE 7

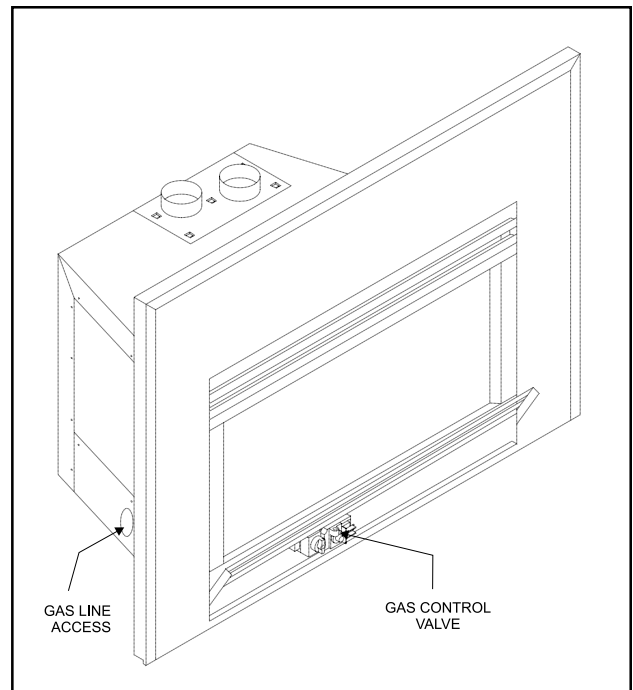

FIGURE 8

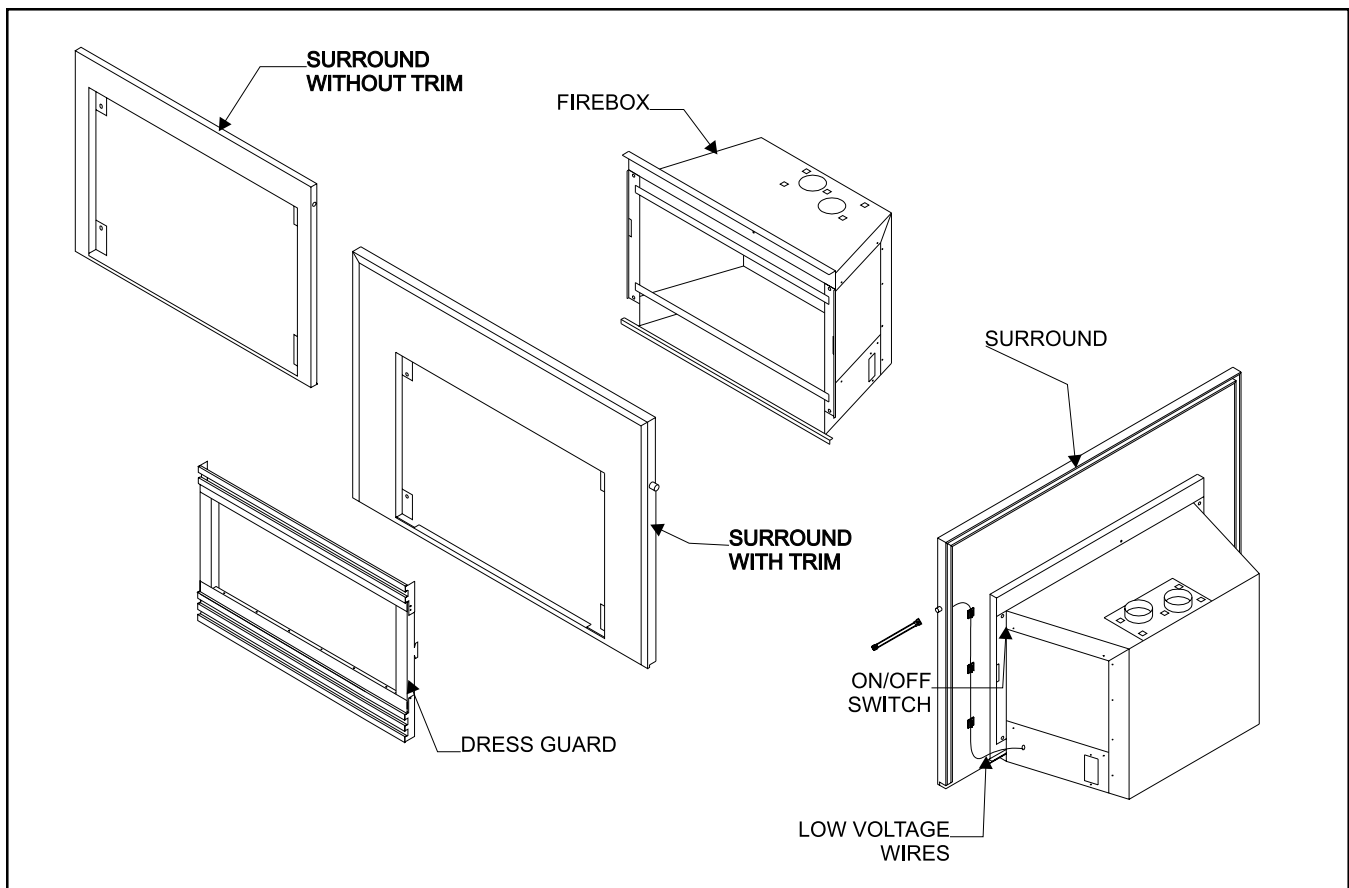

FIGURE 9

## 1.4 FAN

Model ATS-AUST has a factory installed Fan, Junction Box, variable speed Rheostat Control Switch, and Temperature Sensor Switch for the fan. The fan, temperature sensor switch, and junction box are located behind the lower grille. To provide the 240 VAC needed at the Junction Box, simply plug the 3-prong grounded cord into a 3-prong grounded 240 VAC wall outlet. This cord exits the unit at the lower right hand corner.

## 1.5 INSTALLING THE SURROUND

**NOTE: REMOVE FRONT TRIM DOOR AND GLASS DOOR ASSEMBLIES FROM THE INSERT BEFORE SURROUND INSTALLATION.**

1. Find the coiled low voltage wires and ON/OFF switch attached to outer right side of the insert. See Figure 9.
2. Disconnect the ON/OFF switch from the low voltage wire leads, and insert the short wires of the ON/OFF switch through the hole at the upper right corner of the surround and push the back of the switch through the hole - it will be retained in the hole.

3. Run the low voltage lead wires up the back of the right side of the surround and secure them with the three wire ties found there. Reconnect the low voltage wires to the short wires of the ON/OFF switch.
4. Remove and retain the four surround attachment screws at the corners of the face of the unit. See Figure 9.
5. Slide the surround against the face of the unit, aligning the holes in upper and lower, right and left corners and secure the surround to the unit with the attachment screws.

**NOTE: PLACE THE THREE INSULATION PIECES INTO THE CAVITIES AT THE BACK OF THE SURROUND BEFORE POSITIONING THE INSERT INTO THE FACTORY-BUILT OR MASONRY FIREPLACE. THIS INSULATION WILL HELP SEAL FOR COLD AIR LEAKS.**

## LOG PLACEMENT INSTRUCTIONS

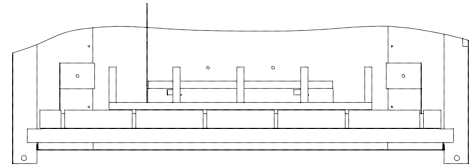
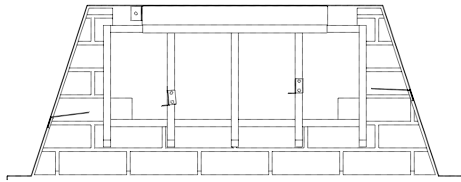
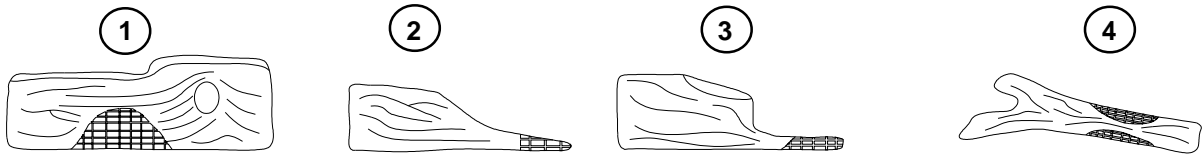

**Step 1.** Place Log Number 1 back against the air intake passage in the back of the box. Slide the log left until it contacts the metal bracket protruding on the left side of the air intake. Drive a wood screw through the hole in this bracket and into the log to positively locate.

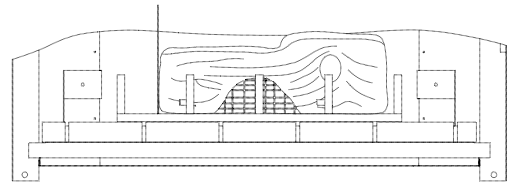
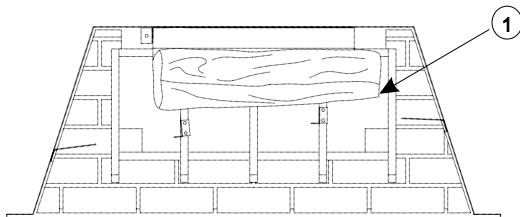

**Step 2.** Place Log Number 2 with the flat side facing the rear on the left side of the grate. Push the right side of the log back so it rests against the tab on the grate. Position the log so it rests against the log bracket at the left side of the firebox. Drive a wood screw through this bracket and into log number 2.

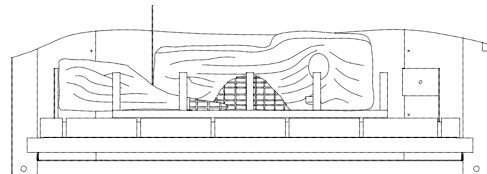
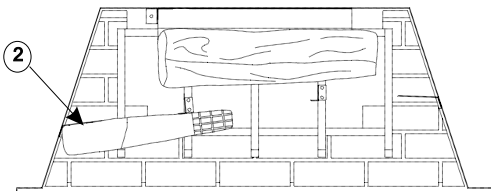

**Step 3.** Place Log Number 3 with its flat side down between the rear log and the front of the grate, on the right side. Position the log so it rests against the log bracket at the right side of the firebox and the tab on the fourth bar of the grate. Secure this log with another screw.

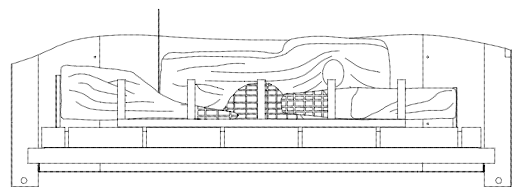
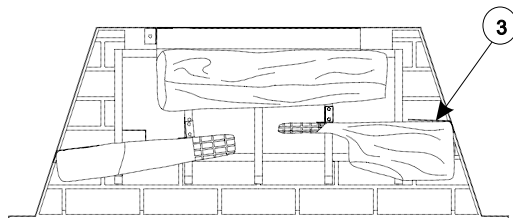

**Step 4.** Place Log Number 4 with its bottom in front of the third and fourth bars of the grate. Position the split end of the log on the top of the rear left side. The inside fork should rest against the rear log location bracket. Tie this log to the rear log with a screw at the location marked "X".

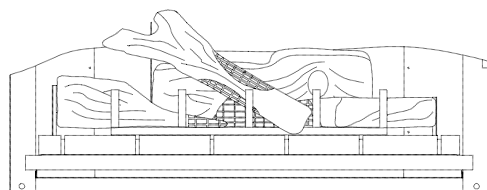
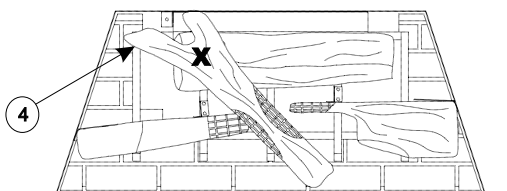

FIGURE 10

## 1.6 FINISHING

Figure 11 shows the minimum vertical and corresponding maximum horizontal dimensions of mantels or other combustible projections above the gas heater.

## 1.7 LOG INSTALLATION

Carefully remove the log package from the fireplace and the logs from their package. **Handle logs gently.**

Place the logs in the fireplace by following the steps shown in Figure 10.

Replace the glass door and trim door previously removed prior to lighting the unit. Be certain the gas logs are properly positioned.

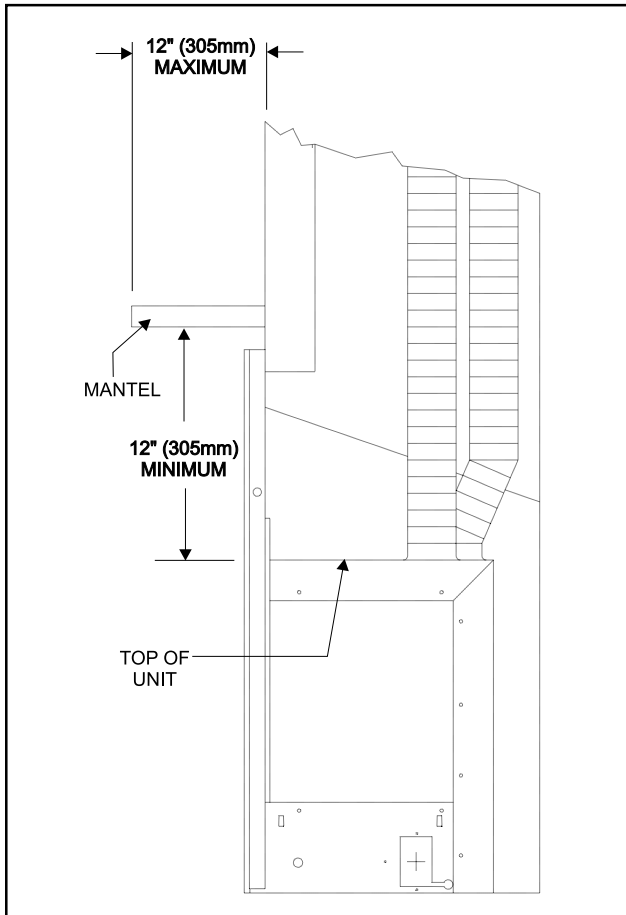

FIGURE 11

## 1.8 INSTALLER TESTING

The space heater must be tested and be operating according to manufacturers specifications prior to the installer leaving the site. Note: the tips of the flames should never hit the top of the firebox after the unit has warmed up. Please contact your dealer or a qualified service person to replace injector or adjust valve.

Upon completing the gas line connection, a small amount of air will be in the lines. When first lighting the pilot light, it will take a few minutes for the lines to

purge themselves of this air. Once the purging is complete, the pilot and burner will light and operate as indicated in the Lighting Instructions.

Subsequent lights of the appliance will not require such purging.

**CAUTION: DURING THE INITIAL PURGING AND SUBSEQUENT LIGHTING'S, NEVER ALLOW THE GAS VALVE CONTROL KNOB TO REMAIN DEPRESSED IN THE "PILOT" POSITION WITHOUT PUSHING THE RED IGNITOR BUTTON AT LEAST ONCE EVERY SECOND.**

Follow the Safety Information and Lighting Instructions pages of this manual to light the appliance.

To obtain proper operation, it is imperative that the pilot and main burner flame characteristics are steady, not lifting or floating. Typically, the 3/8-inch (10mm) at the pilot generator should be engulfed in the pilot flame. (Figure 12).

Burner flame patterns are shown in Figure 13.

Proper gas log positioning is shown in Figure 10.

Follow Section 1.6 TROUBLESHOOTING for adjusting the appliance to operate properly.

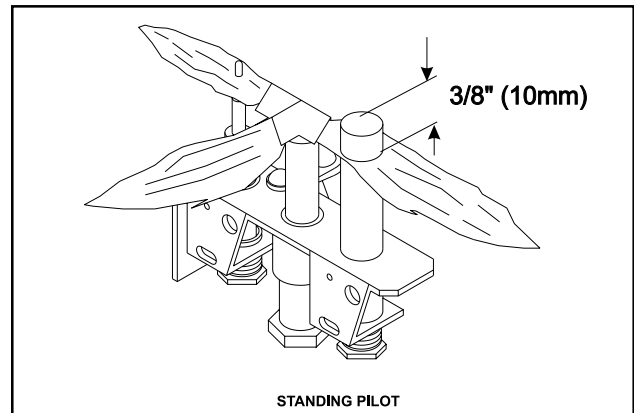

FIGURE 12

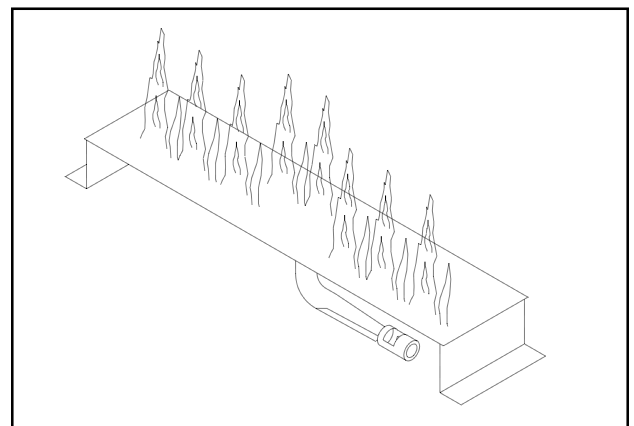
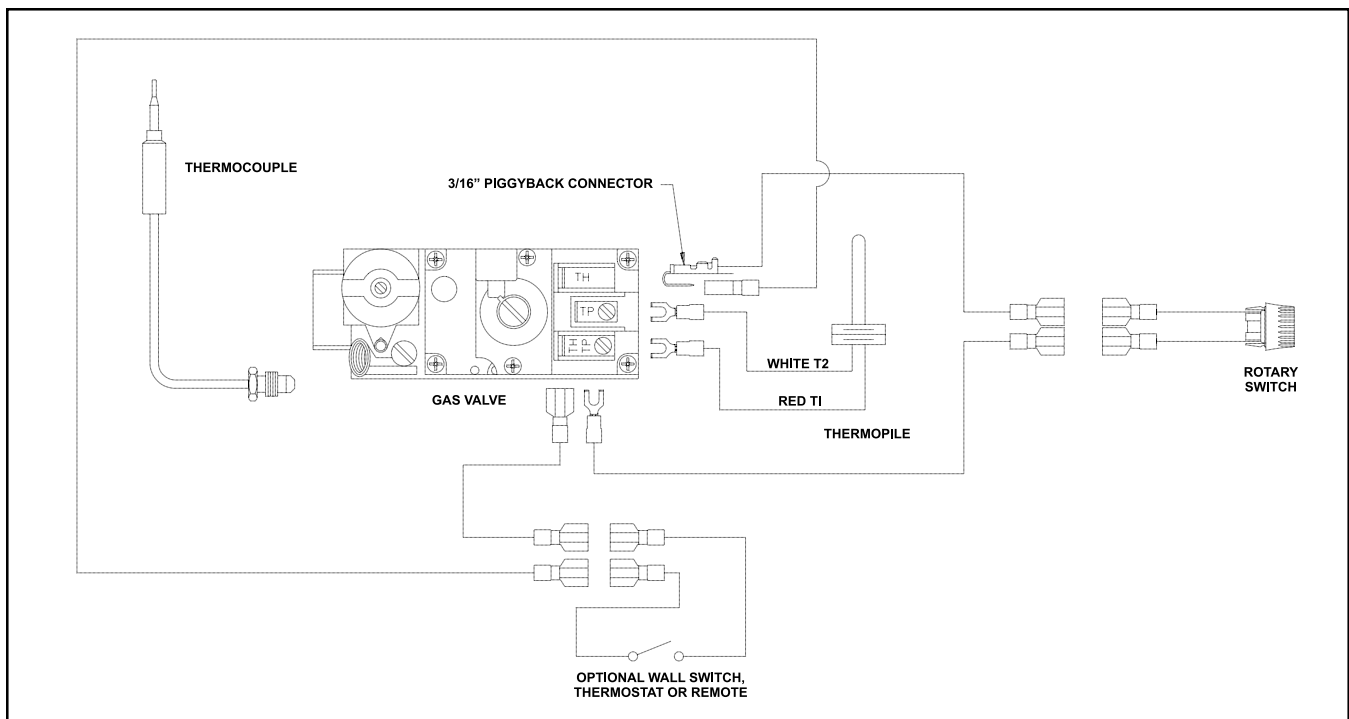

FIGURE 13



**FIGURE 14**

## 2.0 OPERATING INSTRUCTIONS

The control system for these models is a millivolt type. It consists of a gas control valve/variable regulator, a standing pilot assembly, a thermopile, a piezo ignitor, and an ON/OFF rocker switch. The controls are located in the lower compartment behind the lower grille. Access to this compartment is gained by rotating the grille up. See Figure 1.

**WARNING: DO NOT CONNECT 240 VAC TO THE GAS CONTROL VALVE OR CONTROL WIRING SYSTEM OF THIS UNIT.**

The gas control system is wired so the thermopile, when heated with the pilot light, will provide approximately 350 to 500 millivolts. This activates the gas control valve. See Figure 14 for appliance wiring diagram.

When lit for the first time, the appliance will emit a slight odor for an hour or two. This is due to paint and lubricants used in the manufacturing process. Additionally, for the first few minutes after each lighting, vapor may condense and fog the glass and the flames may be blue. After a few minutes this moisture will disappear and within 15-30 minutes the flames should become yellow.

The heater may produce a noise, caused from metal expansion and contraction as it heats up and cools down. This noise is similar to one that a furnace heat duct may produce and does not affect the operation or longevity of the heater.

## OPERATING CAUTIONS

- **THIS APPLIANCE MAY EXHIBIT A SLIGHT CARBON DEPOSITION.**
- **DO NOT PLACE ARTICLES ON OR AGAINST THIS APPLIANCE.**
- **DO NOT USE OR STORE FLAMMABLE MATERIALS NEAR THIS APPLIANCE.**
- **DO NOT SPRAY AEROSOLS IN THE VICINITY OF THIS APPLIANCE WHILE IT IS IN OPERATION.**
- **THE DRESS GUARD IS FITTED TO THIS APPLIANCE TO REDUCE THE RISK OF FIRE OR INJURY FROM BURNS AND NO PART OF IT SHOULD BE PERMANENTLY REMOVED. FOR PROTECTION OF YOUNG CHILDREN OR THE INFIRM, A SECONDARY GUARD IS REQUIRED.**
- **THE GLASS DOOR ASSEMBLY MUST BE IN PLACE AND SEALED AND THE FIXED MESH DRESS GUARD MUST BE IN PLACE ON THE HEATER BEFORE THE UNIT CAN BE PLACED INTO SAFE OPERATION.**
- **DO NOT USE THIS APPLIANCE IF ANY PART HAS BEEN UNDER WATER. IMMEDIATELY CALL A QUALIFIED SERVICE TECHNICIAN TO INSPECT THE UNIT AND TO REPLACE ANY PART OF THE CONTROL SYSTEM AND ANY GAS CONTROL WHICH HAS BEEN UNDERWATER.**

- **DO NOT OPERATE THIS APPLIANCE WITH THE GLASS DOOR REMOVED, CRACKED, OR BROKEN. REPLACEMENT OF THE GLASS DOOR SHOULD BE DONE BY A LICENSED OR QUALIFIED PERSON. DO NOT STRIKE OR SLAM THE GLASS DOOR.**
- **THE GLASS DOOR ASSEMBLY SHALL ONLY BE REPLACED AS A COMPLETE UNIT AS SUPPLIED BY THE GAS HEATER MANUFACTURER. NO SUBSTITUTE MATERIALS MAY BE USED.**

## 2.1 SAFETY AND LIGHTING INFORMATION

Follow Section 2.2 **SAFETY INFORMATION** and 2.3 **LIGHTING INSTRUCTIONS** to light the appliance.

By design, the flame pattern will not be identical from unit to unit. Additionally, flame pattern may vary depending on installation type and weather conditions.

**NOTE: THE TIPS OF THE FLAMES SHOULD NEVER HIT THE TOP OF THE FIREBOX.**

## 2.2 SAFETY INFORMATION

### FOR YOUR SAFETY READ BEFORE LIGHTING

**WARNING: IF YOU DO NOT FOLLOW THESE INSTRUCTIONS EXACTLY, A FIRE OR EXPLOSION MAY RESULT CAUSING PROPERTY DAMAGE, PERSONAL INJURY, OR LOSS OF LIFE.**

- A. This appliance has a pilot. When lighting the pilot, follow these instructions exactly.
- B. BEFORE LIGHTING smell all around the appliance area for gas. Be sure to smell next to the floor because some gas is heavier than air and will settle on the floor.



#### WHAT TO DO IF YOU SMELL GAS

- Do not try to light any appliance.
- Do not touch any electric switch; do not use any phone in your building.
- Immediately call your gas supplier from a neighbor's phone. Follow the gas supplier's instructions.

- C. Use only your hand to push in or turn the gas control knob. Never use tools. If the knob will not push in or turn by hand, don't try to repair it. Call a qualified service technician. Forced or attempted repair may result in a fire or explosion.
- D. Do not use this appliance if any part has been under water. Immediately call a qualified service technician to inspect the appliance and to replace any part of the gas control system which has been under water.

## 2.3 LIGHTING INSTRUCTIONS

### LIGHTING INSTRUCTIONS

1. "STOP!" Read the safety information on previous page.
2. To access controls, open the bottom grille.
3. Turn the valve control knob to the "OFF" position. To do this, you must turn the knob clockwise  to the "Pilot" position, and then press in and continue turning clockwise  to the "OFF" position.

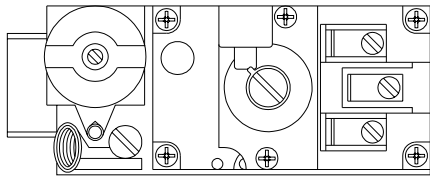

#### GAS CONTROL VALVE

**NOTE:** Knob cannot be turned from "PILOT" to "OFF" unless knob is pushed in slightly. Do not force.



4. WAIT FIVE (5) MINUTES TO CLEAR OUT ANY GAS. Then smell for gas, including near the floor. If you then smell gas, STOP! Follow "B" in the safety information above. If you don't smell gas, go to the next step.
5. The pilot should not require accessing for lighting purposes. The pilot is located inside the combustion chamber. If it is necessary to access the pilot, follow the instructions in Section 5.1 and 5.4 for glass door removal and replacement.

#### PILOT BURNER

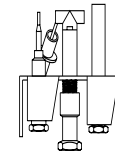
THERMOCOUPLE



THERMOPILE

6. To put the control in the pilot position, turn the control knob counter-clockwise  to the "Pilot" position.
7. To light the pilot depress the control knob and then depress the red piezo button until it makes a clicking sound. It may be necessary to repeat this step. If the pilot does not light after 10 seconds, go back to step 3. The control knob should be held down for a MINUTE after pilot ignition.
  - If the control knob does not pop out when released, **STOP**-shut off the gas supply to the heater control valve, and **IMMEDIATELY** call your service technician or gas supplier.
  - If the pilot will not stay lit after two tries, turn the control knob to the "OFF" position and call your service technician or gas supplier.
8. After the pilot has been lit, the burner can be turned on by turning the knob counter-clockwise  to the "ON" position. Flip the ON/OFF switch to the "ON" position.
9. Close the bottom grille.

### TO TURN OFF GAS APPLIANCE

1. Turn ON/OFF switch to "OFF".
2. Open the bottom grille.
3. Turn the valve control knob clockwise  to the "Pilot" position, then depress knob and continue turning to "OFF" position.
4. Close the bottom grille.

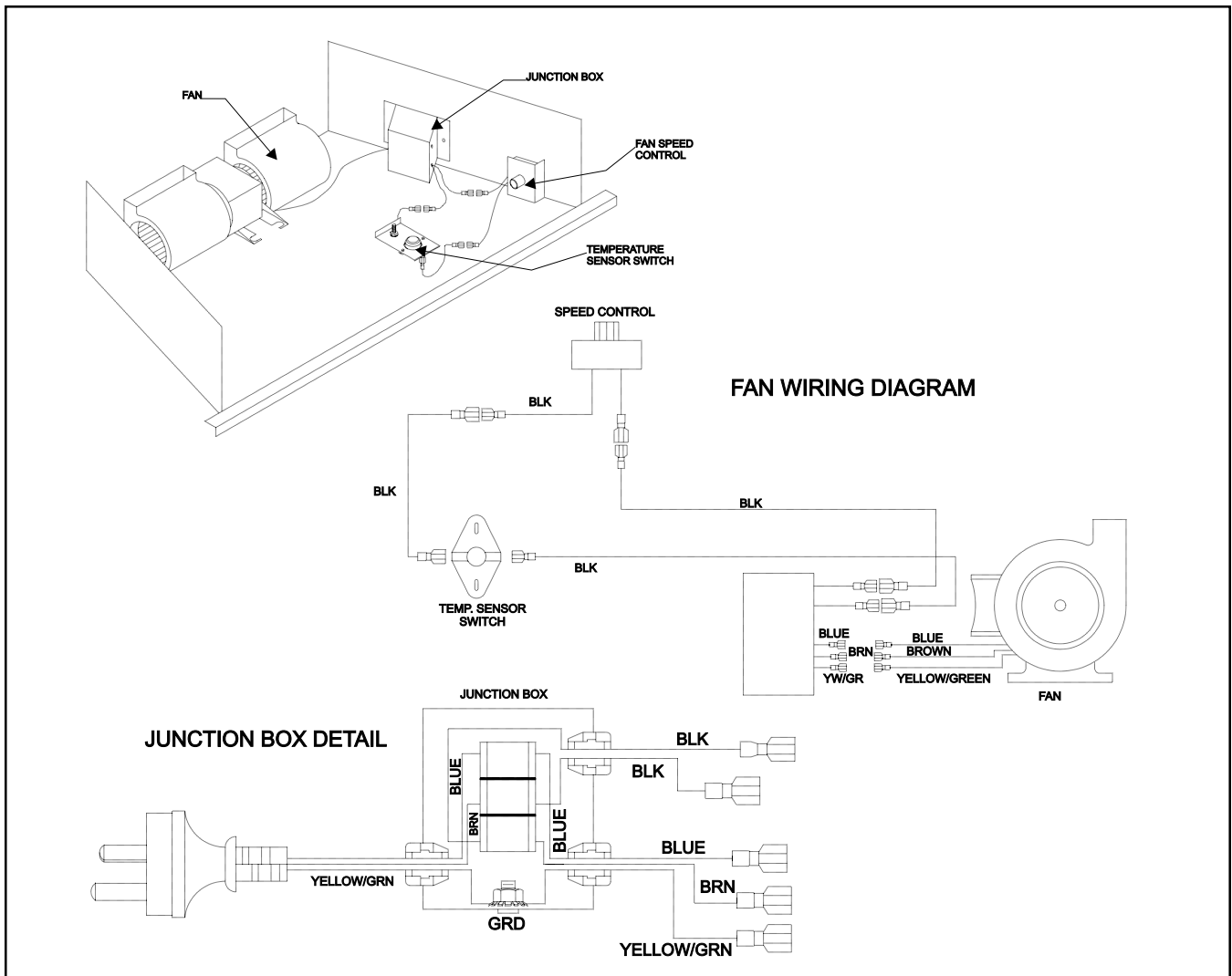

FIGURE 15

## 2.4 FAN OPERATION

The accessory fan is wired in series with a speed control switch and a temperature sensor switch. Set the speed control to an "ON" position and light the heater. The temperature sensor switch will automatically start the fan when the switch warms up—and stop the fan when it cools down. You can manually stop the fan by turning the speed control switch to "OFF". See Figure 15 for fan wiring diagram.

## 3.0 SERVICING AND MAINTENANCE

- A. **HEATER SERVICING:** Frequency of heater servicing will depend upon use and type of installation.
- B. **IMPORTANT:** TURN OFF GAS BEFORE SERVICING APPLIANCE. IT IS RECOMMENDED THAT A COMPETENT SERVICE TECHNICIAN PERFORM SERVICE CHECK-UPS AT THE BEGINNING OF EACH HEATING SEASON.

- C. The appliance and flue system should be inspected before initial use and at least annually by a qualified field service person.
- D. Inspect the external flue cap on a regular basis to make sure that no debris is interfering with the air flow.
- E. Keep the control compartment, logs, and burner area surround the logs clean by vacuuming or brushing at least twice a year.

**CAUTION:** THE LOGS GET VERY HOT - HANDLE ONLY WHEN COOL.



**WARNING: DO NOT USE ABRASIVE CLEANERS ON THE GLASS DOOR ASSEMBLY. DO NOT ATTEMPT TO CLEAN THE GLASS DOOR WHEN IT IS HOT.**

- F. The glass door should be cleaned using a household glass cleaner. **DO NOT** handle or attempt to clean the glass when it is **HOT**.
- G. In order to properly clean the burner and pilot assembly, turn off the gas to the unit and remove the logs exposing the burner and pilot assembly. Clean all foreign materials from top of burner. Check to make sure that the burner orifice is clean.

Visually inspect the pilot periodically. Brush or blow away any dust or linen accumulations. If the pilot orifice is plugged, disassembly may be required to remove any foreign materials from the orifice or tubing.

When the appliance is put back in service check burner flame patterns with Figure 13.

To obtain proper operation, it is imperative that the pilot and main burner flame characteristics are steady, not lifting or floating. Typically, the top 3/8-inch (9.5mm) at the pilot generator should be engulfed in the pilot flame (Figure 12).

### 3.1 REMOVAL OF COVERS FOR SERVICING

1. Control Compartment Grille
  - Rotate the bottom grille up to access the gas controls.
2. Dress Guard and Glass Door
  - Lift the front dress guard up and out away from the appliance side surrounds. Replace the dress guard when servicing is complete.
  - Rotate the three spring latch eye-bolts, at the top of the glass door, releasing the glass frame. Carefully lift the glass door up and out away from the appliance.

### 3.2 REMOVAL OF COMPONENTS FOR SERVICE

1. Burner
  - Carefully lift up and remove the log set, log grate, and refractory.
  - Unscrew the brackets at both ends of the burner and slide the burner to the right away from the burner orifice.

2. Pilot Assembly/Ignition System
  - Remove the log set, log grate, and refractory.
  - Disconnect the gas supply tube from the underside of the pilot burner.
  - Disconnect the electrode wire from the piezo ignitor (found adjacent to the gas control valve).
  - Unscrew the pilot assembly bracket and remove. **NOTE:** When removing the pilot assembly, carefully pull the electrode wire up through the grommeted hole in the base pan.

### 3.3 PARTS REPLACEMENT

1. Fan
  - Unplug the power cord.
  - Remove the electrical cover plate from the lower right hand side of the heater. Loosen the retaining screws on the wire connector to disconnect the fan wires. Discount earth wire from junction box stud.
  - Slide the fan out the front of the lower controls compartment.

**NOTE:** The glass panel must be removed BEFORE fan is removed.

2. Fan Speed Control
  - Disconnect the wires from the fan speed control switch, pull off the knob, and remove the nut holding the speed control to the bracket.
3. Temperature Sensor
  - Disconnect the wires from the fan temperature sensor switch and remove the nut holding the switch bracket onto the side of the firebox.
4. Glass Panel
  - To replace the glass door, place the bottom edge in the bottom mounting brackets. Push glass against unit and latch the eye-bolts into the brackets. Rotate the eye-bolts to secure.

### 3.4 ADJUSTMENTS AND REPLACEMENT PARTS

Adjustments and replacement parts for this appliance should only be done by a qualified service person. A wiring diagram for the appliance is shown in **SECTION 2.0 OPERATING INSTRUCTIONS**. A replacement part table is shown in **SECTION 4.0** of this manual.

### 3.5 TROUBLE SHOOTING - ATS-AUST

With proper installation and maintenance, your new Gas Heater should provide years of trouble-free service. If you do experience a problem, refer to the Trouble Shooting Guide below. This guide will assist a qualified service person in the diagnosis of problems and the corrective action to be taken.

SYMPTOM	POSSIBLE CAUSE	CORRECTIVE ACTION
<b>I. Spark Ignitor will not light pilot after repeated triggering of red button.</b>	A. Defective ignitor (no spark at electrode).	1. Check for spark at electrode and pilot; if no spark and electrode wire is properly connected, replace ignitor.
	B. Defective pilot or misaligned electrode (spark at electrode).	1. Using a match, light pilot. If pilot lights, turn off pilot and trigger the red button again. If pilot lights, an improper gas/air mixture caused the bad lighting and a longer purge period is recommended. If pilot will not light - check gas at electrode and pilot - should be 1/8 inch (3.2mm) to have a strong spark. If OK, replace pilot.
	C. No gas or low gas pressure.	1. Check unit's shut-off valve and remote shut off valves from heater. Usually there is a valve near the main. There can be more than one (1) valve between the heater and main.  2. Low pressure can be caused by a variety of situations such as a bent line, too narrow diameter of pipe or even low line pressure. Check for kinked lines. If none, consult with plumber or gas supplier.
	D. No L.P. in tank.	1. Check L.P. (propane) tank. Refill the fuel tank.
<b>II. Pilot will not stay lit after carefully following lighting instructions.</b>	A. Defective thermocouple.	1. Check that pilot flame impinges on thermocouple. Clean and/ or adjust pilot for maximum flame impingement.  2. Ensure that the thermocouple connection at the gas valve is fully inserted and tight (hand tight plus 1/4 turn).



SYMPTOM	POSSIBLE CAUSE	CORRECTIVE ACTION
<b>III. Pilot burning, no gas burner, valve knob "ON", "on-off" switch "ON".</b>	B. Defective valve.	3. Disconnect the thermocouple from the valve, place one millivolt meter lead wire on the tip of the thermocouple and the other meter lead wire on the thermocouple copper lead. Start the pilot and hold the valve knob in. If the millivolt reading is less than 15 mv, replace the thermocouple.  1. If thermocouple is producing more than 15 millivolts, replace faulty valve.
	A. "ON-OFF" switch or wires defective.	1. Check "on-off" switch and wires for proper connections. Place jumper wires across terminals at switch-if burner comes on, replace defective switch. If OK, place jumper wires across switch wires at gas valve-if burner comes on, wires are faulty or connections are bad.
	B. Thermopile may not be generating sufficient millivoltage.	1. If the pilot flame is not close enough physically to the thermopile, adjust the pilot flame.  2. Be sure the wire connections from the thermopile at the gas valve terminals are tight and the thermopile is fully inserted into the pilot bracket.  3. Check the thermopile with a millivolt meter. Take the reading at TH-TP & TP terminals of the gas valve. The meter should read 325 millivolts minimum, while holding the valve knob depressed in the pilot position, with the pilot lit, and the ON/OFF switch in the OFF position. Replace the faulty thermopile if the reading is below the specified minimum.

SYMPTOM	POSSIBLE CAUSE	CORRECTIVE ACTION
<b>V. Frequent pilot outage problem.</b>	A. Pilot flame may be too high or too low, or blowing (high), causing pilot safety to drop out.	<p>With the pilot in the ON position, disconnect the thermopile leads from the valve. Take a reading at the thermopile leads. The reading should be 325 millivolts minimum. Replace the thermopile if the reading is below the minimum.</p> <p>1. Clean and adjust pilot flame for maximum flame impingement on the thermocouple. Follow lighting instruction carefully.</p>
	C. Defective valve.	<p>1. Turn valve knob to "ON". Place ON/OFF switch to "ON". Check with millivolt meter at thermopile terminals. Millivolt meter should read greater than 100 m.v. If the reading is okay and the burner does not come on, replace the gas valve.</p>
	D. Plugged burner orifice.	<p>1. Check burner orifice for stoppage and remove.</p>
	E. Wall switch, or wires defective.	<p>1. Follow corrective action in A.1 above; check switch and wiring. Replace where defective.</p>

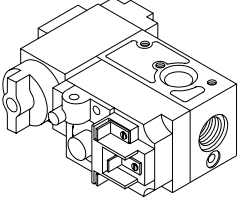
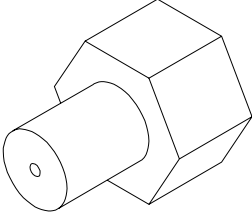
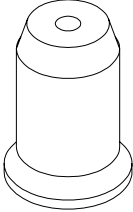

SYMPTOM	POSSIBLE CAUSE	CORRECTIVE ACTION
<b>V. The pilot and main burner extinguish while in operation.</b>	A. No L.P. in tank.	1. Check L.P. (Propane) tank. Re-fill fuel tank.
	B. Inner flue pipe leaking exhaust gases back into system.	1. Check for leaks.
	C. Glass too loose and air tight, gasket leaks in corners after usage.	1. Be certain glass assembly is installed correctly and tighten corner.
	D. Horizontal flue improperly pitched.	1. The horizontal flue cap should slope down only enough to prevent any water from entering the unit. The maximum downward slope is 1/4 inch.
	E. Bad thermopile or thermocouple.	1. Replace if necessary.
	F. Improper flue cap installation.	1. Check for proper installation and freedom from debris or blockage.
<b>VI. Glass soots.</b>	A. Flame impingement on logs.	1. Adjust the log set so that the flame does not excessively impinge on it.
	B. Improper venturi setting.	1. Adjust the air shutter at the base of the burner.
	C. Debris around venturi.	1. Inspect the opening at the base of the burner. It is imperative that <b>NO</b> material be placed in this opening.
<b>VII. Flame burns blue and lifts off burner.</b>	A. Insufficient oxygen being supplied	1. Check to make sure flue cap is installed properly and free of debris. Make sure that flue system joints are tight and have no leaks. 2. Check to make sure that no material has been placed at the burner base. 3. Be sure glass is tightened properly on unit, particularly on top corners.

## 4.0 REPLACEMENT PARTS-ATS-AUST

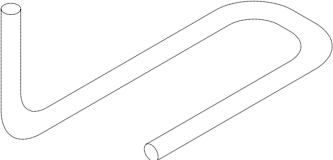
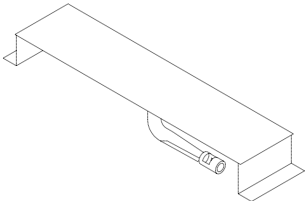
When requesting service or replacement parts for your fireplace, please provide model number and serial number. All parts listed in this manual may be ordered from an authorized dealer.

PART	PART DESCRIPTION	PART NUMBER
	Robertshaw Valve LP	SRV60-522
	Robertshaw Valve NG	SRV60-523
	Burner Orifice LP	SRV57-801
	Burner Orifice NG	SRV57-800
	Pilot Orifice LP	SRV60-517
	Pilot Orifice NG	SRV60-505
	Pilot Tube	SRV428-301
	Burner Tube	SRV491-300
	Burner NG	SRV491-328A
	Burner LP	SRV491-327A

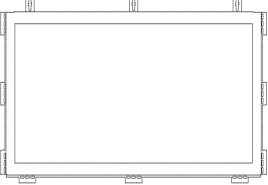
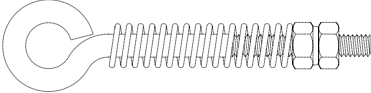
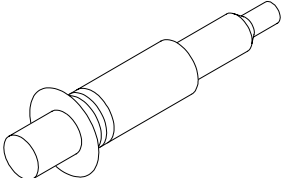
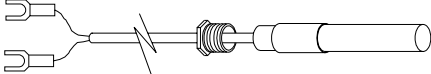
#### 4.0 REPLACEMENT PARTS-ATS-AUST (CONT.)

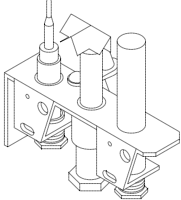
PART	PART DESCRIPTION	PART NUMBER
	Glass Assembly	SRV438-650A
	Glass Fastener Assembly	SRV79-001A
	Piezo Ignitor	SRV60-513
	Thermopile	SRV60-512
	On/Off Rotary Switch	SRV436-525A
	Pilot Assembly LP	SRV60-515A
	Pilot Assembly NG	SRV60-514A

#### 4.0 REPLACEMENT PARTS-ATS-AUST (CONT.)

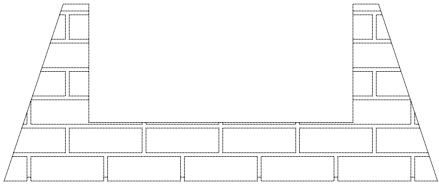
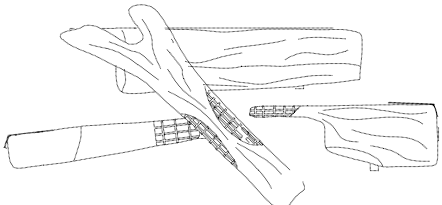
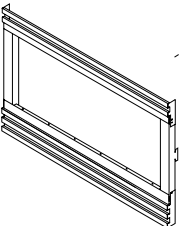
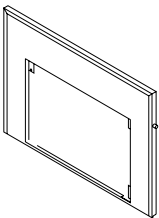
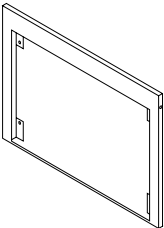
PART	PART DESCRIPTION	PART NUMBER
	Refractory Base	SRV438-700
	Log Set Assembly	SRV428-700A
	Dress Guard	DF-ATS-AU
	Surround With Trim	ATS-AU-4028
	Surround	ATS-AU-3626



**LIMITED 10 YEAR WARRANTY  
HEAT-N-GLO GAS FIREPLACE PRODUCTS**

In order to presumptively establish the dates to which your HEAT-N-GLO Limited Warranty runs, you must mail the completed warranty card to HEAT-N-GLO FIREPLACE PRODUCTS, INC., 6665 West Highway 13, Savage, MN 55378, within 60 days of the date of the fireplace installation. If you fail to do so, you may be required to prove the date of installation before warranty work can be performed.

The warranty exclusions and limitations of liability are effective upon installation of the fireplace.

Subject to the conditions set forth herein, HEAT-N-GLO FIREPLACE PRODUCTS, INC. ("HEAT-N-GLO") extends the following warranty with respect to HEAT-N-GLO Gas Fireplace Products.

If HEAT-N-GLO is reasonably satisfied that any part or portion of the fireplace covered by this Limited Warranty is defective in material or workmanship under normal use and service as described in the Operating Instructions, HEAT-N-GLO will take the following actions:

1. If the defect is reported during the first year from the date of installation (stainless steel burners and fiber logs are covered for 3 years), HEAT-N-GLO will replace or repair the defective components at its sole expense. The decision whether to replace a component shall be made at HEAT-N-GLO's sole discretion. This Limited Warranty does not cover components broken during shipping, misuse or careless handling. HEAT-N-GLO shall be not responsible for any indirect, incidental, or consequential damages or for any costs other than those incurred by HEAT-N-GLO to repair or replace the defective component. If components (including venting) other than factory approved components are used, all warranty and liability on the fireplace is voided. **Defects reported after the first year will not be covered by warranty unless they fall within the purview of paragraph 2 or 3 below.**
2. If the following defects are reported during the second year after the date of installation, HEAT-N-GLO will supply replacement parts at the current wholesale price: defective electrical or manual components, optional components or accessories, and glass panels (not including glass panels broken during misuse or careless handling). HEAT-N-GLO shall not be responsible for any labor, transportation or other costs. Furthermore, it shall not be liable for any indirect, incidental or consequential damages.
3. HEAT-N-GLO will replace or repair a defective firebox or heat exchanger, at any time during the 10 years from the date of installation. The decision whether to replace the defective component shall be made at HEAT-N-GLO's sole discretion. HEAT-N-GLO shall not be responsible for any indirect, incidental or consequential damages or for any costs other than those incurred by HEAT-N-GLO to repair or replace the defective component.

This Limited Warranty is the exclusive remedy available to you. If HEAT-N-GLO cannot effectively resolve a warranty problem in an expedient and cost-effective manner, it can discharge its entire warranty liability by refunding the price of the product to you.

Products made by other manufacturers, whether sold with the fireplace or added thereafter, are NOT covered by this Limited Warranty. The use of other unauthorized components will make this warranty null and void. This Limited Warranty will also be void if the appliance is not installed by a qualified installer in accordance with the Installation Instructions. Furthermore, the Limited Warranty will be void if the fireplace is not operated, at all times, according to the Operating Instructions furnished with the fireplace. Any service work must be performed by authorized service representatives.

EXCEPT TO THE EXTENT PROVIDED BY LAW, NO OTHER EXPRESS OR IMPLIED WARRANTIES, INCLUDING WARRANTIES OF MERCHANTABILITY OR FITNESS FOR A PARTICULAR PURPOSE, SHALL APPLY TO THE FIREPLACE PRODUCT. In States that do not allow limitations on how long an implied warranty lasts, or do not allow exclusion of indirect damages, those limitations or exclusions may not apply to you. You may also have additional rights not covered in this Limited Warranty.

HEAT-N-GLO reserves the right to make changes at any time, without notice, in design, material, specifications and prices. It also reserves the right to discontinue styles and products.