

Installation Manual

Installation and Appliance Setup

INSTALLER: Leave this manual with party responsible for use and operation.

OWNER: Retain this manual for future reference.

NOTICE: DO NOT discard this manual!

HEARTH & HOME
technologies



Models:
B41L-AU

Ref No: GMK10636
AS/NZS 5263.1.8

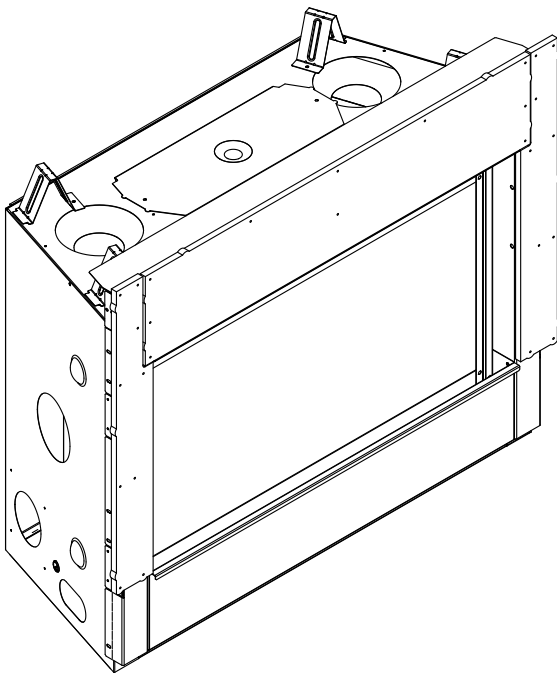

**NOTE: NOT INTENDED FOR
FIREPLACE INSERT.**

⚠ WARNING:
FIRE OR EXPLOSION HAZARD
Failure to follow safety warnings exactly could result in serious injury, death, or property damage.

- **DO NOT** store or use gasoline or other flammable vapors and liquids in the vicinity of this or any other appliance.
- **What to do if you smell gas**
 - **DO NOT** try to light any appliance.
 - **DO NOT** touch any electrical switch. **DO NOT** use any phone in your building.
 - Leave the building immediately.
 - Immediately call your gas supplier from a neighbor's phone. Follow the gas supplier's instructions.
 - If you cannot reach your gas supplier, call the fire department.
- Installation and service must be performed by a qualified installer, service agency, or the gas supplier.

⚠ DANGER



**HOT GLASS WILL
CAUSE BURNS.**

**DO NOT TOUCH GLASS
UNTIL COOLED.**

**NEVER ALLOW CHILDREN
TO TOUCH GLASS.**

A barrier designed to reduce the risk of burns from the hot viewing glass is provided with this appliance and shall be installed for the protection of children and other at-risk individuals.

DO NOT PLACE ARTICLES ON OR AGAINST THIS APPLIANCE.

DO NOT USE OR STORE FLAMMABLE MATERIALS NEAR THIS APPLIANCE.

DO NOT SPRAY AEROSOLS IN THE VICINITY OF THIS APPLIANCE WHILE IT IS IN OPERATION.

DO NOT MODIFY THIS APPLIANCE.

▲ Safety Alert Key:

- **DANGER!** Indicates a hazardous situation which, if not avoided will result in death or serious injury.
- **WARNING!** Indicates a hazardous situation which, if not avoided could result in death or serious injury.
- **CAUTION!** Indicates a hazardous situation which, if not avoided, could result in minor or moderate injury.
- **NOTICE:** Used to address practices not related to personal injury.

Note: The term “recommend” or “recommended” does not indicate a requirement. It is a best practice suggested by Hearth & Home Technologies®. Failure to perform the recommended task will not result in a safety concern.

Table of Contents

→ Installation Standard Work Checklist	3
--	---

1 Product Specific and Important Safety Information

A. Appliance Certification	4
B. Glass Specifications	4
C. Gas Pressure Requirements	4
D. High Altitude Installations	5
E. Non-Combustible Materials Specification	5
F. Combustible Materials Specification	5
G. Electrical Codes	5

2 Getting Started

A. Design and Installation Considerations	6
B. Good Faith Wall Surface/TV Guidelines	6
C. Tools and Supplies Needed	7
D. Inspect Appliance and Components	7

3 Framing and Clearances

A. Appliance/Decorative Front Dimension Diagrams	8
→ B. Clearances to Combustibles	10
C. Constructing the Appliance Chase	15

4 Termination Location and Vent Information

A. Vent Termination Minimum Clearances	16
B. Chimney Diagram	17
C. Approved Pipe	18
D. Use of Elbows	18
E. Measuring Standards	19
F. Vent Diagrams	20

5 Vent Clearances and Framing

A. Pipe Clearances to Combustibles	30
B. Wall Penetration Framing/Firestops	30
C. Ceiling Firestop/Floor Penetration Framing	31
D. Install Attic Insulation Shield	31

6 Appliance Preparation

A. Vent Collar Preparation	32
B. Prepare For Heat Management	32
C. Securing and Leveling the Appliance	33
D. Non-Combustible Material Installation	34

7 Venting and Chimneys

A. Assemble Vent Sections	35
B. Assemble Slip Sections	36
C. Secure the Vent Sections	36
D. Disassemble Vent Sections	37
E. Vertical Termination Requirements	38
F. Horizontal Termination Requirements	39

8 Electrical Information

A. General Information	40
B. Wiring Requirements	41

9 Gas Information

A. Fuel Conversion	42
B. Gas Pressure	42
C. Gas Service Access	42
D. Gas Connection	44
E. High Altitude Installations	44
F. Air Shutter Setting	44

10 Finishing

A. Facing Material	45
B. Non-Combustible Board and Drywall Installation	46
C. Mantel and Wall Projections	48
D. Decorative Barrier Front Finishing	50

11 Appliance Setup

A. Remove the Shipping Materials	54
B. Clean the Appliance	54
C. Install the Glass Refractory (Optional)	54
D. Install Log Set or Other Optional Media - Driftwood Logs - Stones	54
E. Fixed Glass Assembly Removal and Replacement	57
F. Install Decorative Barrier Front	58

12 Reference Materials

A. Vent Components Diagrams	59
B. Accessories	63

→ = Contains updated information.

Installation Standard Work Checklist

ATTENTION INSTALLER: Follow this Standard Work Checklist

This standard work checklist is to be used by the installer in conjunction with, not instead of, the instructions contained in this installation manual.

Customer: _____
Lot/Address: _____

Model: B41L-AU

Date Installed: _____
Location of Fireplace: _____
Installer: _____
Dealer/Distributor Phone # _____
Serial #: _____

 **WARNING! Risk of Fire or Explosion!** Failure to install appliance according to these instructions could lead to a fire or explosion. Install **ONLY** components and accessories approved by **Hearth & Home Technologies**. Unapproved components and accessories could cause appliance to overheat.

Appliance Install	YES	IF NO, WHY?
Verified that the chase is insulated and sealed. (Pg. 16)	<input type="checkbox"/>	_____
Required non-combustible board is installed. (Pg. 35)	<input type="checkbox"/>	_____
Verified clearances to combustibles. (Pg. 10)	<input type="checkbox"/>	_____
Fireplace is leveled and secured. (Pg. 34)	<input type="checkbox"/>	_____

<u>Venting/Chimney</u> Section 7 (Pg 36-40)		
Venting configuration complies to vent diagrams.	<input type="checkbox"/>	_____
Venting installed, locked and secured in place with proper clearance.	<input type="checkbox"/>	_____
Firestops installed.	<input type="checkbox"/>	_____
Attic insulation shield installed.	<input type="checkbox"/>	_____
Exterior wall/Roof flashing installed and sealed.	<input type="checkbox"/>	_____
Terminations installed and sealed.	<input type="checkbox"/>	_____

<u>Electrical</u> Section 8 (Pg 41-42)		
Unswitched power (220-240 VAC) provided to the appliance.	<input type="checkbox"/>	_____
Switch wires properly installed.	<input type="checkbox"/>	_____

<u>Gas</u> Section 9 (Pg 43-45)		
Proper appliance for fuel type.	<input type="checkbox"/>	_____
Was a conversion performed?	<input type="checkbox"/>	_____
Leak check performed and inlet pressure verified.	<input type="checkbox"/>	_____
Verified proper air shutter setting for installation type.	<input type="checkbox"/>	_____

<u>Finishing</u> Section 10 (Pg 46-54)		
Combustible materials not installed in non-combustible areas.	<input type="checkbox"/>	_____
Verified all clearances meet installation manual requirements.	<input type="checkbox"/>	_____
Mantels and wall projections comply with installation manual requirements.	<input type="checkbox"/>	_____

<u>Appliance Setup</u> Section 11 (Pg 55-59)		
All packaging and protective materials removed (inside & outside of appliance).	<input type="checkbox"/>	_____
Logs and optional media, and glass refractory installed correctly.	<input type="checkbox"/>	_____
Fan deflector brackets installed and Glass assembly installed and secured.	<input type="checkbox"/>	_____
Accessories installed properly.	<input type="checkbox"/>	_____
Mesh, doors, or decorative barrier front properly installed.	<input type="checkbox"/>	_____
Manual bag and all of its contents are removed from inside/under the appliance and given to party responsible for use and operation.	<input type="checkbox"/>	_____
Started appliance and verified no gas leaks exist.	<input type="checkbox"/>	_____

Hearth & Home Technologies recommends the following:

- Photographing the installation and copying this checklist for your file.
- That this checklist remain visible at all times on the appliance until the installation is complete.

Comments: Further description of the issues, who is responsible (Installer/ Builder/ Other Trades, etc) and corrective action needed _____

Comments Communicated to party responsible _____ by _____ on _____
 (Builder / Gen. Contractor/) (Installer) (Date)

➔ = Contains updated information.

2570-982C 7/20

1 Product Specific and Important Safety Information

A. Appliance Certification

MODEL: B41L-AU
LABORATORY: IAPMO OCEANA
TYPE: Direct Vent Heater
STANDARD: AS/NZS 5263.1.8

The Hearth & Home Technologies gas appliances discussed in this Installer's Guide have been tested to certification standards and listed by the applicable laboratories.

This appliance must be installed in accordance with the AS/NZS 5601.1 rules in force.

NOT INTENDED FOR USE AS A PRIMARY HEAT SOURCE.
This appliance is tested and approved as either supplemental room heat or as a decorative appliance. It should not be factored as primary heat in residential heating calculations.

B. Glass Specifications

Hearth & Home Technologies appliances manufactured with tempered glass may be installed in hazardous locations such as bathtub enclosures as defined by the Consumer Product Safety Commission (CPSC). The tempered glass has been tested and certified to the requirements of **ANSI Z97.1** and **CPSC 16 CFR 1202** (Safety Glazing Certification Council **SGCC# 1595** and **1597**. Architectural Testing, Inc. Reports **02-31919.01** and **02-31917.01**).

C. Gas Pressure Requirements

Pressure requirements for B41L-AU fireplaces are shown in table below.

Two taps are provided on the right hand side of the gas control for a test gauge connection to measure the inlet and outlet pressures.

The fireplace and its individual shut-off valve must be disconnected from the gas supply piping system during any pressure testing of the system at test pressures in excess of 3.4 kPa.

If the fireplace must be isolated from the gas supply piping system by closing an individual shut-off valve, it must be of the handle-less type.

NOTE: An inline fuel pressure regulator is recommended to limit NG inlet pressure to 2.49 kPa, and Propane inlet pressure to 3.25 kPa, to ensure optimum product performance. The inline fuel pressure regulator may be needed if any of the following symptoms exist: pilot jetting, a highly visible pilot flame, flame variation, etc. The inline pressure regulator should be installed in the gas line upstream of the appliance gas valve either at the appliance or in the utility room. Final main and manifold gas pressure must be tested with inline pressure regulator installed.

	Natural Gas	Propane
Inlet Gas Pressure	1.13 - 3.40 kPa	2.75 - 3.40 kPa
* Outlet (Manifold) Gas Pressure	0.76 kPa	2.40 kPa
Nominal Gas Consumption	20.0 MJ/h	20.0 MJ/h
Burner Injector	#44 DMS (2.18 mm)	#55 DMS (1.32 mm)
Pilot Injector	Ø .023 (.584 mm)	Ø .014 (.356 mm)

Gas types only through field conversions.

* The allowable Outlet (Manifold) Gas Pressure ranges are: Natural Gas 0.63 - 0.95 kPa (0.76 kPa nominal) and Propane 2.37 - 2.61 kPa (2.40 kPa nominal). Certification testing setpoint values are shown.

D. High Altitude Installations

NOTICE: *If the heating value of the gas has been reduced, these rules do not apply. Check with your local gas utility or authorities having jurisdiction.*

When installing above 2000 ft. (610 m) elevation:

Reduce input rate 4% for each 1000 ft. (305 m) above 2000 ft. (610 m).

E. Non-Combustible Materials Specification

Material which will not ignite and burn. Such materials are those consisting entirely of steel, iron, brick, tile, concrete, slate, glass or plasters, or any combination thereof.

Materials that are reported as passing **ASTM E 136, Standard Test Method for Behavior of Materials in a Vertical Tube Furnace at 750 °C (1382 °F)** shall be considered non-combustible materials.

F. Combustible Materials Specification

Materials made of or surfaced with wood, compressed paper, plant fibers, plastics, or other material that can ignite and burn, whether flame proofed or not, or plastered or unplastered shall be considered combustible materials.

G. Electrical Codes

All electrical safety testing has been done following the EN 60335-2-102 standard. Local codes apply.

Installation Manual

Models:
B41L-AU

ADDENDUM

PLEASE NOTE

Factory fitted non-combustible board must be fitted on any installation regardless of finishing materials. Removal is a fire risk and will void the unit warranty.

Minimum 6mm cement sheeting or other suitable non-combustible material (such as tiles or stone) must be clad over factory fitted boards on unit.

2 Getting Started

A. Design and Installation Considerations

Hearth & Home Technologies direct vent gas appliances are designed to operate with all combustion air siphoned from outside of the building and all exhaust gases expelled to the outside. No additional outside air source is required.

Installation **MUST** comply with local, regional, state and national codes and regulations. Consult insurance carrier, local building inspector, fire officials or authorities having jurisdiction over restrictions, installation inspection and permits.

Before installing, determine the following:

- Where the appliance is to be installed.
- The vent system configuration to be used.
- Gas supply piping.
- Electrical wiring requirements.
- Framing and finishing details.
- Whether optional accessories—devices such as a wall switch or remote control—are desired.

Installation and service of this appliance should be performed by qualified personnel. Hearth & Home Technologies recommends HHT Factory Trained or NFI certified professionals.



Improper installation, adjustment, alteration, service or maintenance can cause injury or property damage. For assistance or additional information, consult a qualified service technician, service agency or your dealer.

B. Good Faith Wall Surface/TV Guidelines

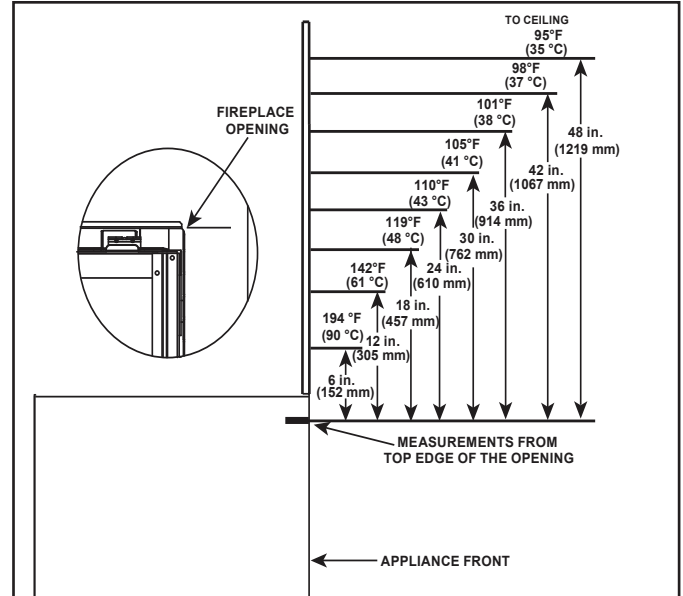

Figure 2.1 Good Faith Wall Surface Temperatures Above Appliance

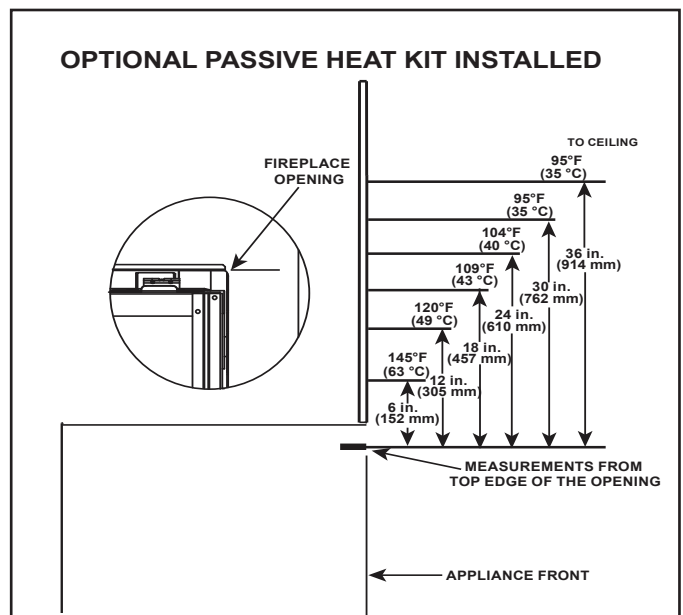

Figure 2.2 Good Faith Wall Surface Temperatures Above Appliance with Passive Heat Kit Installed

If installing a television (TV) above the appliance, see Section 3 of the appliance Owner's Manual.

NOTICE: Surface temperatures listed above are taken with a temperature measuring probe as prescribed by the test standard used for appliance certification. Temperatures on walls or mantels taken with an infrared thermometer may yield increased temperatures of up to 30 °F (17 °C) or more depending on the thermometer settings and material characteristics being measured. Use appropriate finishing materials that are able to withstand these conditions. For additional finishing guidelines, see Section 10.

C. Tools and Supplies Needed

Before beginning the installation be sure that the following tools and building supplies are available.

Hand Tools	Tape measure
Level	Framing material
Manometer	Framing square
Voltmeter	Electric drill and bits -1/4 in.(6.mm)
Plumb line	Safety glasses/Gloves
Wrenches	Reciprocating saw
1/4 in. (6 mm) nut driver	
Non-corrosive leak check solution	
1/2 - 3/4 in.(13-19 mm) length, #6 or #8 Self-drilling screws	
Caulking material (300 °F (149 °C) minimum continuous exposure rating)	

D. Inspect Appliance and Components

WARNING! Risk of Fire or Explosion! Damaged parts could impair safe operation. **DO NOT** install damaged, incomplete or substitute components. Keep appliance dry.

WARNING! Risk of Fire, Explosion or Electric Shock! **DO NOT** use this appliance if any part has been under water. Call a qualified service technician to inspect the appliance and to replace any part of the control system and/or gas control which has been under water.

- Carefully remove the appliance and components from the packaging.
- The vent system components and decorative barrier fronts may be shipped in separate packages.
- If packaged separately, the log set and appliance grate must be installed.
- Report to your dealer any parts damaged in shipment.

Hearth & Home Technologies disclaims any responsibility for, and the warranty will be voided by, the following actions:

- Installation and use of any damaged appliance or vent system component.
- Modification of the appliance or vent system.
- Installation other than as instructed by Hearth & Home Technologies.
- Improper positioning of the logs/media (as applicable) or the glass assembly.
- Installation and/or use of any component part not approved by Hearth & Home Technologies.

3 Framing and Clearances

A. Appliance/Decorative Front Dimension Diagrams

Dimensions are actual appliance dimensions. Use for reference only.
For framing dimensions and clearances refer to Section 5.

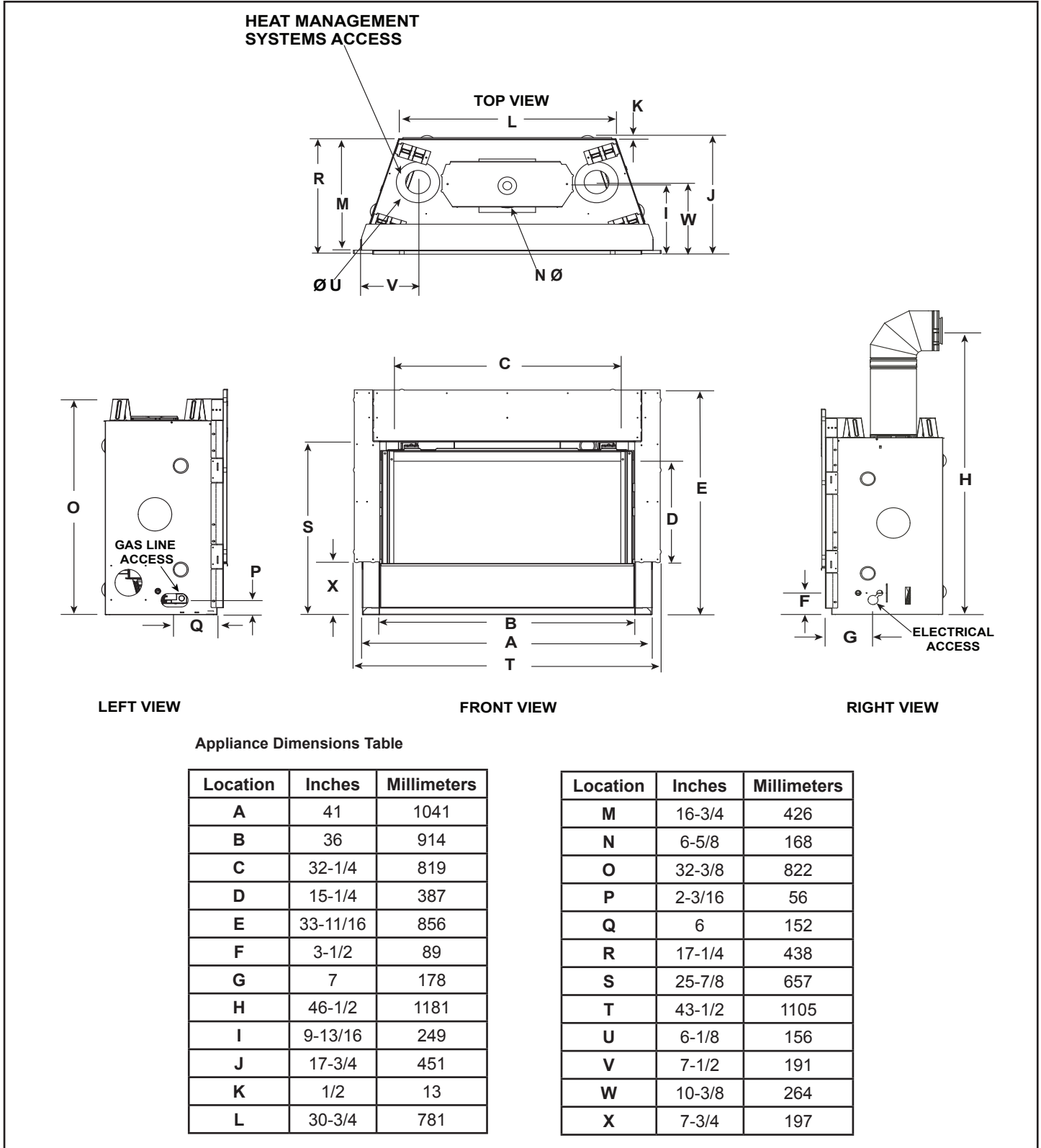

Figure 3.1 Appliance Dimensions

CFTF DECORATIVE BARRIER FRONTS

Dimensions are actual decorative barrier front dimensions. Use for reference only.

IMPORTANT! This fireplace requires an installed decorative barrier front to prevent direct contact with the hot viewing glass. **DO NOT** operate the fireplace with the barrier removed.

Decorative barrier front must be ordered at time of fireplace purchase. If decorative barrier front is not present, contact dealer.

Note: See Section 10 for hearth, mantel and finishing requirements.

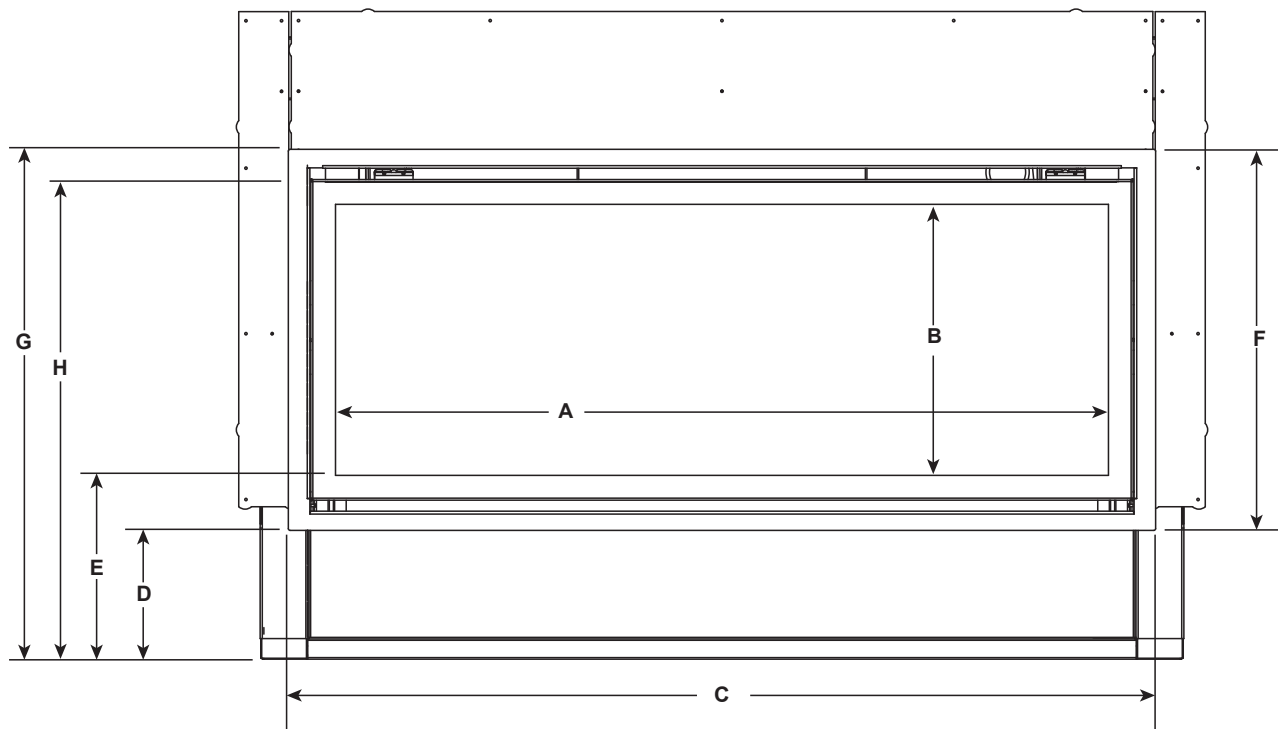

			A	B	C	D	E	F	G	H
B41L-AU	CFTF-36	in.	33-3/16	14-1/8	38-1/8	6-7/8	9-13/16	19-7/8	26-7/8	25-3/16
		mm	843	359	968	175	249	505	683	640

Figure 3.2 Decorative Barrier Front Dimensions - CFTF

B. Clearances to Combustibles

When selecting a location for the appliance it is important to consider the required clearances to walls. See Figure 3.3.

WARNING! Risk of Fire or Burns! Provide adequate clearance around air openings and for service access. Due to high temperatures, the appliance should be located out of traffic and away from furniture and draperies.

NOTICE: Illustrations reflect typical installations and are FOR DESIGN PURPOSES ONLY. Illustrations/diagrams are not drawn to scale. Actual installation could vary due to individual design preference.

It is important to follow the framing and finishing instructions step by step to ensure proper placement of fireplace in the surrounding framing/finishing materials.

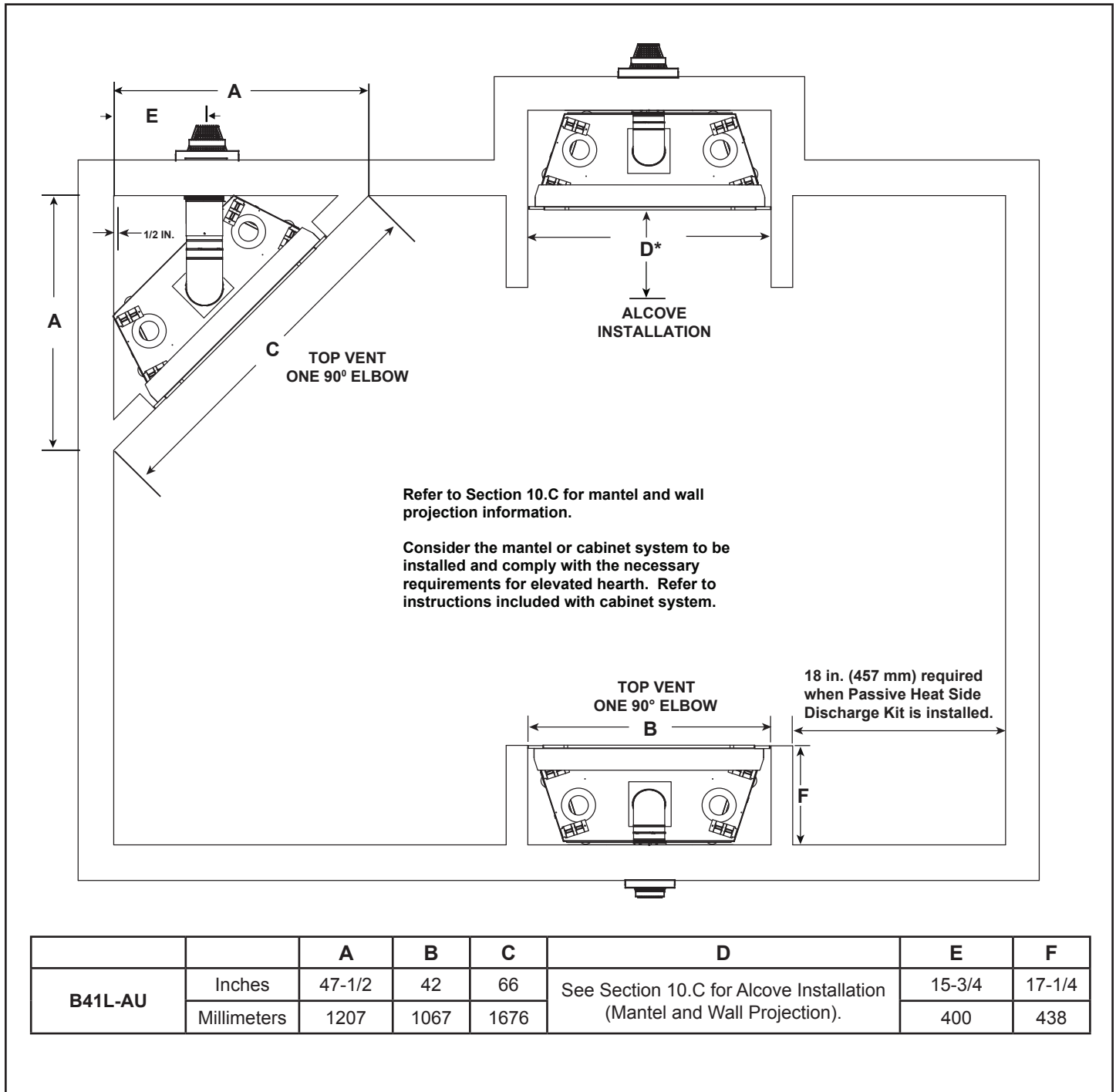

Figure 3.3 Appliance Locations

Framing

This appliance is designed to be recessed into combustible framing with non-combustible material pre-installed on top and side. Drywall or combustible materials (minimum 10 mm thick) are designed to contact the non-combustible material/appliance as called out in Section 10 Finishing.

This appliance has been thoroughly tested to minimize drywall cracking and/or the protrusion of screws "screw pops" when framed as shown above.

Framing should be done in a manner similar to framing a window or door: double - 2 x 4 / 2 x 6 (90 x 35 mm for AU) as a Header for horizontal strength and utilizing Jack or Trimmer Stud fastened to the King Studs for vertical strength.

If elevating the appliance, the base of the unit should also be constructed in a similar manner to prevent settling.

Note: Refer to Section 10 for important information related to facing, drywall specifications and decorative front information.

Note: Header **MUST** be installed on end as shown in the diagram.

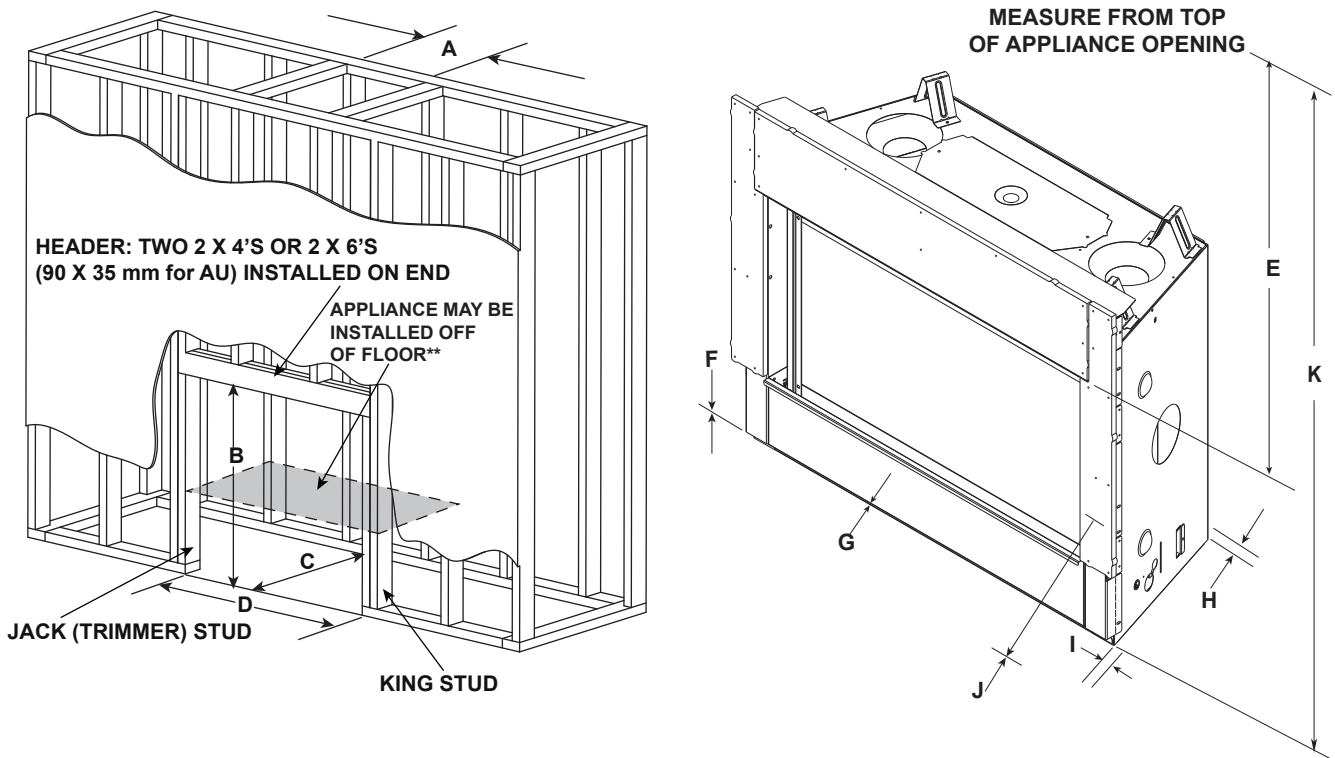

NOTE: E & K dimensions will change if Passive Heat option is installed. Reference the instructions included with the Passive Heat Kit.

		MINIMUM FRAMING DIMENSIONS*										
Model Size		A	B	C	D	E	F	G	H	I	J	K
		Rough Opening (Vent Pipe)	Rough Opening (Height)	Rough Opening (Depth)	Rough Opening (Width)	Clearance to Room Ceiling	Combustible Floor	Minimum Hearth Required	Behind Appliance	Sides of Appliance	Front of Appliance	Clearance to Ceiling
B41L-AU	in.	8-5/8	32-3/4	17-3/4	42	31	0	0	1/2	1/2	36	56-7/8
	mm	219	832	451	1067	787	0	0	13	13	914	1445

* Adjust framing dimensions for interior chase sheathing (such as sheetrock)

** If appliance is installed off of floor, maintain required clearances to combustibles. Construct platform in accordance with local building codes.

Figure 3.4 Clearances to Combustibles

Framing Dimensions - Passive Heat Front Discharge (PH-FRT-LINEAR)

Front Discharge: Air conveyed into the room through one front discharge slot.

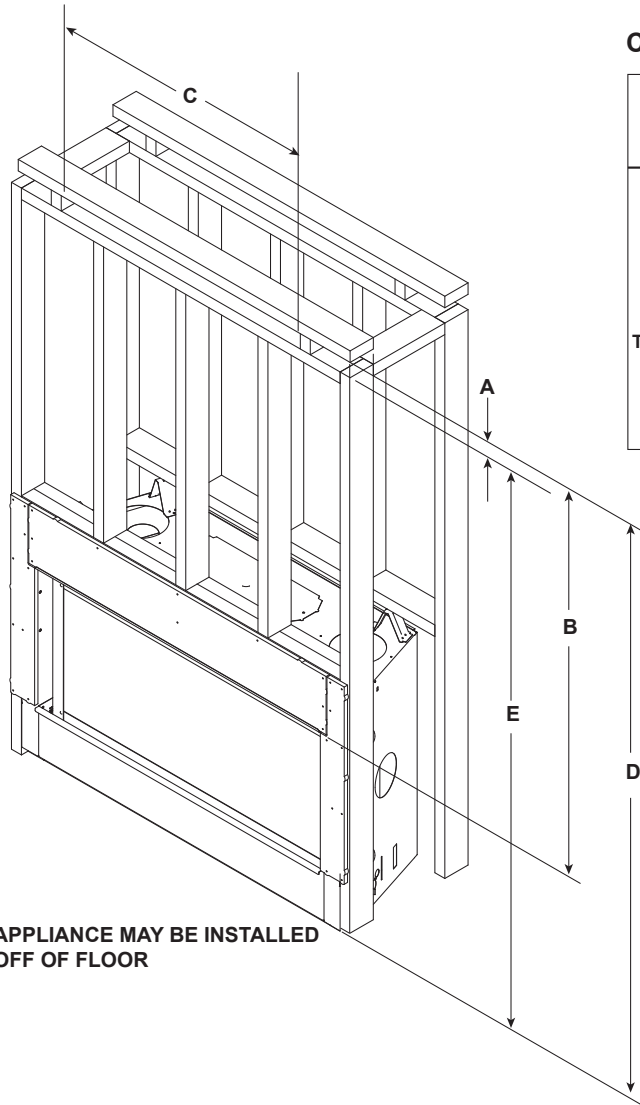

CHASE DETAIL

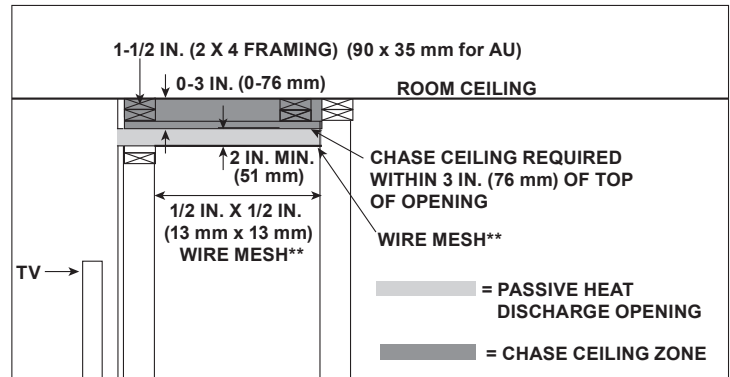

WARNING! Risk of Fire! Wire mesh required on bottom of discharge opening (Dimension A) when finished discharge opening is greater than 3 in. (76 mm). Secure mesh to top of framing.

WARNING! Risk of Fire! Optional fan may not be used with passive heat installation.

FRONT DISCHARGE MINIMUM FRAMING DIMENSIONS

		A		B	C	D	E
		TRIM KIT* INSTALLED (PHTRIM-LINEAR)	NO TRIM KIT**				
		Required Height of Discharge Opening	Height of Discharge Opening				
		Clearance to Top of Discharge Opening	Width of Discharge Opening	Clearance to Top of Discharge Opening From Bottom of Appliance	Clearance from Bottom of Appliance to Bottom of Discharge Opening		
B41L-AU	Inches	3-1/2	2	48	36-1/2	73-7/8	71-7/8
	millimeters	89	51	1219	927	1876	1826

→ * Measurement for Trim Kit = 3-1/2 in. (89 mm) + Additional Finishing Material Thickness. Figure 3.6 shows vent cover dimensions.

** Measurement without Trim Kit = 2 in. (51 mm) + Additional Finishing Material Thickness. If finished discharge opening height is greater than 3 in. (76 mm), wire mesh is required.

Figure 3.5 Passive Heat Front Discharge Framing Dimensions With and Without a Trim Kit

Passive Heat Front Discharge (PH-FRT-LINEAR) Trim Kit

Vent Cover Dimensions

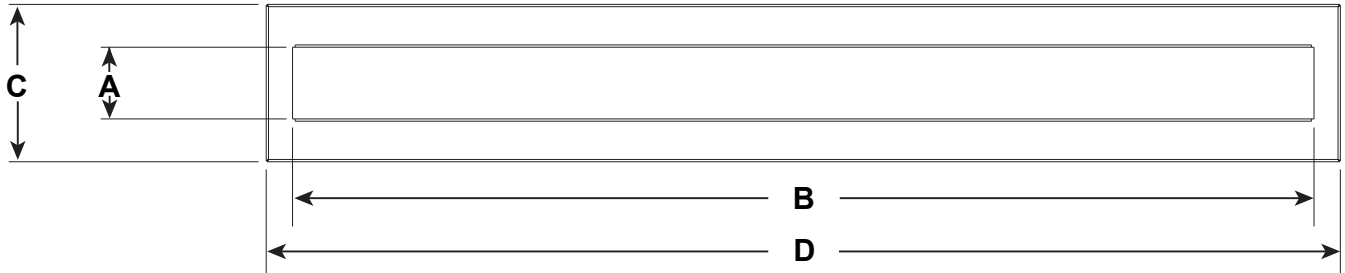

SIDE DISCHARGE FRAMING DIMENSIONS					
		A	B	C	D
		Inside Height	Inside Width	Outside Height	Outside Width
PHTRIM-36LINEAR	Inches	2-9/16	36-1/2	5-5/8	38-3/8
	millimeters	65	927	143	975

→ Figure 3.6 Passive Heat Front Discharge - Vent Cover Dimensions

Framing Dimensions - Passive Heat Side Discharge (PH-SIDE-LINEAR)

Side Discharge: Air conveyed into the room through two discharge registers, one on each side of appliance.

WARNING! Risk of Fire! DO NOT place combustible objects or combustible materials in non-combustible zone. Appliance and combustible materials will overheat.

CHASE DETAIL

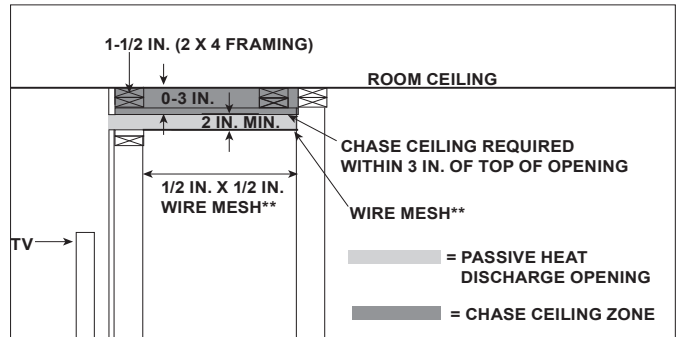

WARNING! Risk of Fire! Optional fan may not be used with passive heat installation.

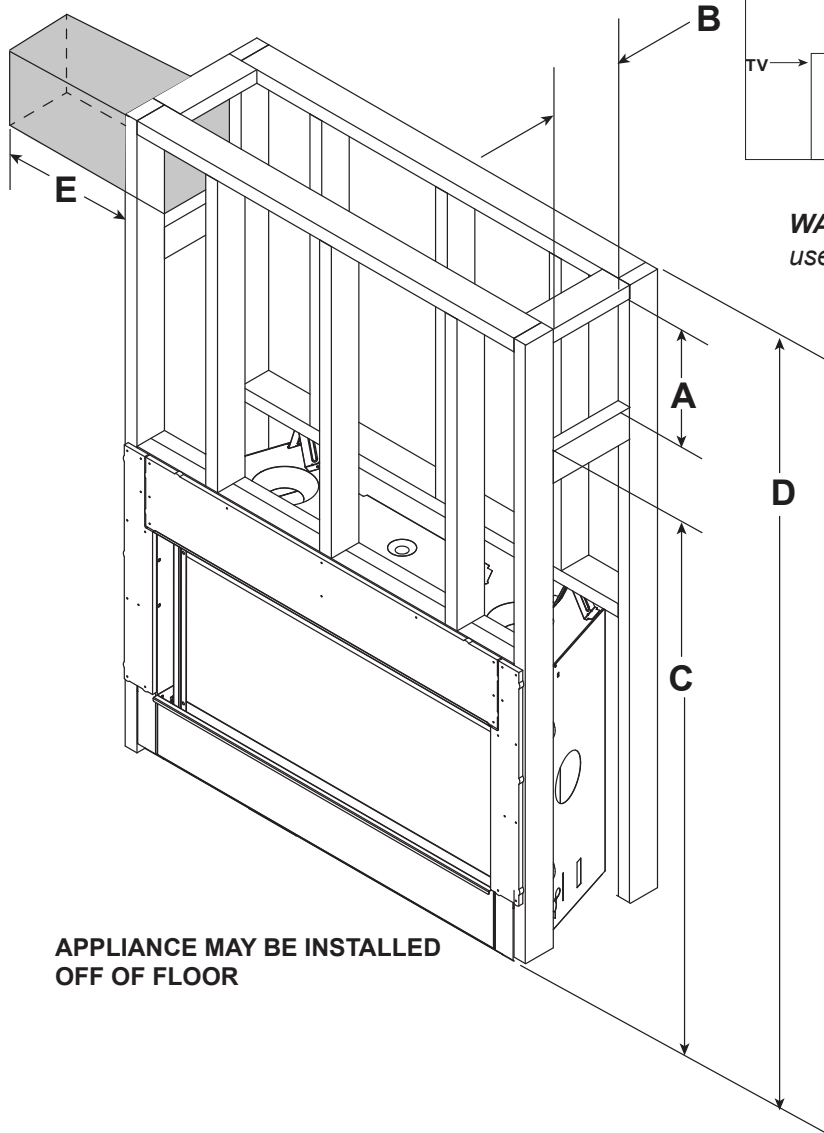

APPLIANCE MAY BE INSTALLED OFF OF FLOOR

SIDE DISCHARGE FRAMING DIMENSIONS						
		A	B	C	D	E
		Height of Discharge Opening	Width of discharge Opening	Minimum Clearance to Discharge Opening	Minimum Clearance Bottom of Appliance to Ceiling	Minimum Clearance to Combustible Materials
B41L-AU	Inches	12-1/4	8-3/4	63-5/8	77-3/8	18
	millimeters	311	222	1616	1965	457

Figure 3.7 Passive Heat Side Discharge Framing Dimensions

Framing Dimensions - Passive Heat Open Top Discharge (PH-FRT-LINEAR)

Open Top Discharge: Both sides and the top are open allowing air to be conveyed into the room.

WARNING! Risk of Fire! Mesh screen required on bottom of discharge opening when discharge opening is greater than 3 in. (76 mm). Secure mesh to top of framing.

WARNING! Risk of Fire! Optional fan may not be used with passive heat installation.

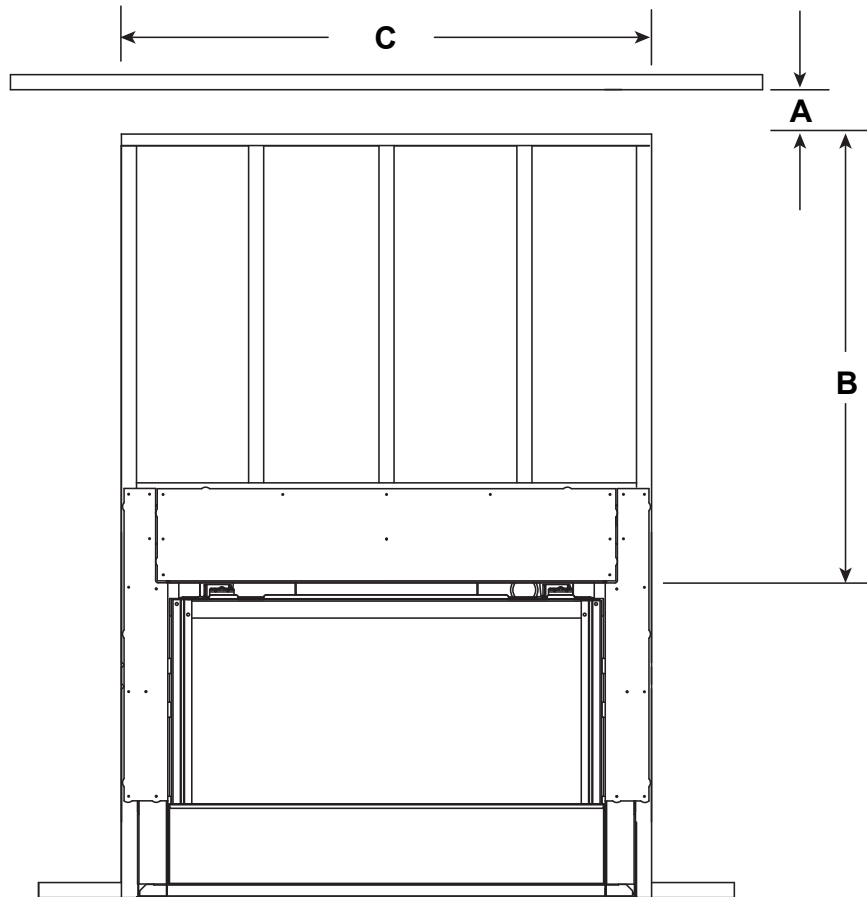

OPEN TOP DISCHARGE MINIMUM FRAMING DIMENSIONS

		A*	B	C
		Height of Discharge Opening	Clearance to Discharge Opening	Width of Discharge Opening
B41L-AU	Inches	2	48	36-1/2
	millimeters	51	1219	927

* Mesh screen required for front discharge or open top discharge passive heat installations with discharge opening of 3 in. (76 mm) or greater.

Figure 3.8 Passive Heat Minimum Framing Dimensions Open Top Discharge

C. Constructing the Appliance Chase

NOTICE: Install appliance on hard metal or wood surfaces extending full width and depth. **DO NOT** install directly on carpeting, vinyl, or any combustible material other than wood.

WARNING! Risk of Fire! Maintain specified air space clearances to appliance and vent pipe:

- Insulation and other materials must be secured to prevent accidental contact.
- The chase must be properly blocked to prevent blown insulation or other combustibles from entering and making contact with fireplace or chimney.
- Failure to maintain airspace may cause overheating and a fire.

A chase is a vertical box-like structure built to enclose the gas appliance and/or its vent system. In cooler climates the vent should be enclosed inside the chase.

NOTICE: Treatment of ceiling firestops and wall shield firestops and construction of the chase may vary with the type of building. These instructions are not substitutes for the requirements of local building codes. Therefore, you **MUST** check local building codes to determine the requirements to these steps.

NOTICE: When installing a sprinkler head in a fireplace chase, it is recommended to use a sprinkler head with a sprinkler activation temperature classified as Extra High. Keep sprinkler head away from vent and chimney.

Chases should be constructed and insulated in the same manner as the thermal envelope of the home based on the code requirements for that climate zone to prevent air leakage and draft problems. The chase is an extension of the building thermal envelope.

To further prevent drafts and air leakage, the wall shield and ceiling firestops should be sealed with caulk with a minimum of 300 °F (149 °C) continuous exposure rating to seal gaps. Gas line holes and other openings should be sealed with caulk with a minimum of 300 °F (149 °C) continuous exposure rating or stuffed with unfaced insulation. If the appliance is being installed on a cement surface, a layer of plywood may be placed underneath to prevent conducting cold up into the room.

4 Termination Location and Vent Information

A. Vent Termination Minimum Clearances

WARNING

Fire Risk.
Maintain vent clearance to combustibles as specified.

- **DO NOT** pack air space with insulation or other materials.

Failure to keep insulation or other materials away from vent pipe could cause overheating and fire.

Angle	H (Min.) mm
0°-26.6°	500*
26.6°-30.3°	500*
30.3°-33.7°	500*
33.7°-36.9°	610*
36.9°-39.8°	760*
39.8°-42.5°	990
42.5°-45.0°	1220
45.0°-49.4°	1520
49.4°-53.1°	1830
53.1°-56.3°	2130
56.3°-59.0°	2290
59.0°-60.3°	2440

*910 mm minimum in snow regions

A	B
6 in. (152 mm) (minimum) up to 20 in. (508 mm)	18 in. (457 mm) minimum
20 in. (508 mm) and over	0 in. minimum

* If using decorative cap cover(s), this distance may need to be increased. Refer to the installation instructions supplied with the decorative cap cover.

** In a staggered installation with both gas and wood or fuel oil terminations, the wood or fuel oil termination cap must be higher than the gas termination cap.

Figure 4.2 Staggered Termination Caps

Figure 4.1 Minimum Height From Roof To Lowest Discharge Opening

B. Chimney Diagram

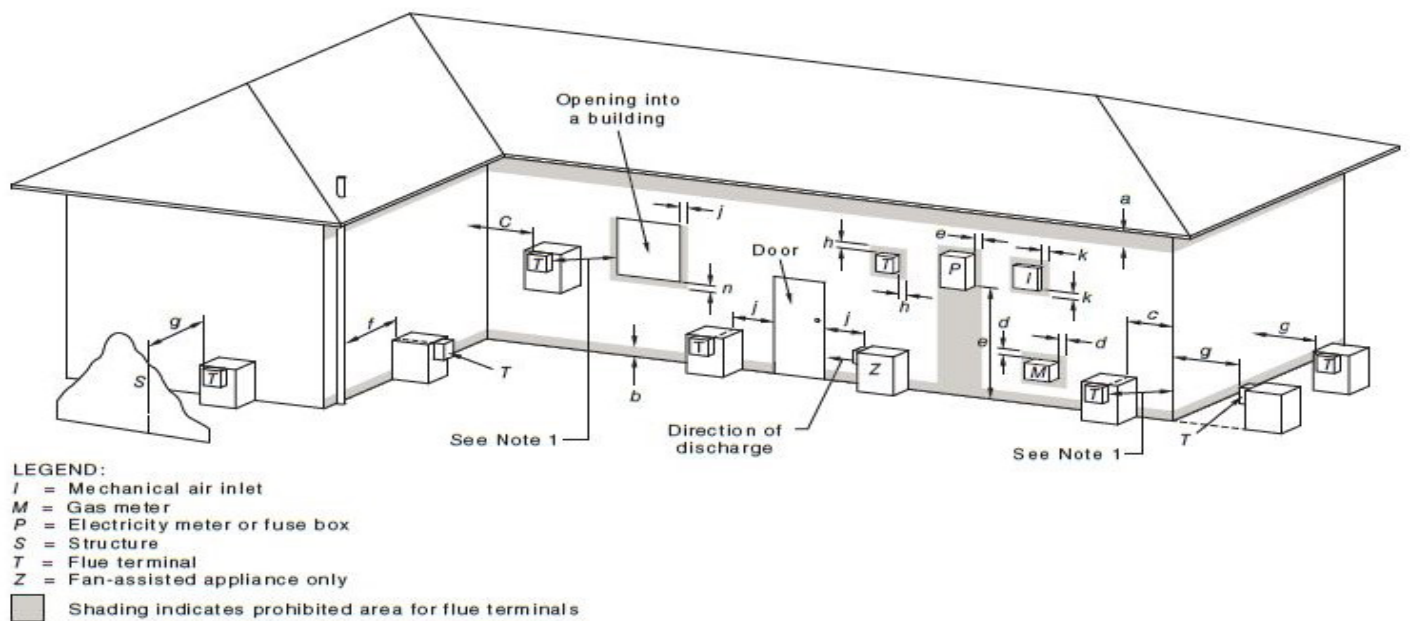

Ref.	Item	Minimum Clearance (mm)	
		Natural Draft	Fan Assisted
a	Below eaves, balconies or other projections		
	Appliances up to 50 MJ/h input	300	200
b	From the ground or above a balcony		
	Appliances 32 MJ/h and below	300	355
	Appliances from 32 MJ/h to 53 MJ/h	300	410
c	From a return wall or external corner	500	300
d	From a gas meter (M)	1000	1000
e	From an electricity meter or fuse box (P)	500	500
f	From a drain or soil pipe	150	75
g	Horizontally from any building structure (unless appliance approved for closer installation) or obstruction facing a terminal	500	500
h	From any other flue terminal, cowl, or combustion air intake	500	300
j	Horizontally from an openable window, door, non-mechanical air inlet, or any other opening into a building, with the exception of sub-floor ventilation		
	Appliances up to 150 MJ/h input	500	300
	All fan assisted appliances in the direction of discharge	-	1500
k	From a mechanical air inlet, including a spa fan	1500	1000
n	Vertically below an openable window, non-mechanical air inlet or any other opening into a building, with the exception of See table sub-floor ventilation		
	For other appliances up to 50 MJ/h input	500	500

- NOTES:**
- All distances are measured vertically or horizontally along the wall to a point in line with the nearest part of the terminal.
 - Prohibited area below electricity meter or fuse box extends to ground level.
 - Flue terminal under covered area:
 - The covered area or recess shall be open on at least two sides.
 - Fan assisted flue appliance shall have at least one side open and the terminal shall be within 500 mm of the opening and discharging in the direction of the opening.
 - Clearance from a flue terminal to a LP cylinder shall be a minimum of 1 meter.

MINIMUM CLEARANCES REQUIRED FOR BALANCED FLUE TERMINALS OR THE FLUE TERMINALS OF OUTDOOR APPLIANCES

Figure 4.3 Minimum Clearances for Termination

C. Approved Pipe

Approved Pipe - Rigid

This appliance is approved for use with Hearth & Home Technologies SLP venting systems. Refer to Section 12.A for vent component information and dimensions.

DO NOT mix pipe, fittings or joining methods from different manufacturers.

The pipe is tested to be run inside an enclosed wall. There is no requirement for inspection openings at each joint within the wall.

WARNING! Risk of Fire or Asphyxiation. This appliance requires a separate vent. **DO NOT** vent to a pipe serving a separate solid fuel burning appliance.

D. Use of Elbows

Diagonal runs have both vertical and horizontal vent aspects when calculating the effects. Use the rise for the vertical aspect and the run for the horizontal aspect. See Figure 4.4.

Two 45° elbows may be used in place of one 90° elbow. On 45° runs, one foot of diagonal is equal to 8-1/2 in. (216 mm) horizontal run and 8-1/2 in. (216 mm) vertical run. A length of straight pipe is allowed between two 45° elbows. See Figure 4.4.

Figure 4.5 shows the vertical and horizontal offsets for SLP elbows.

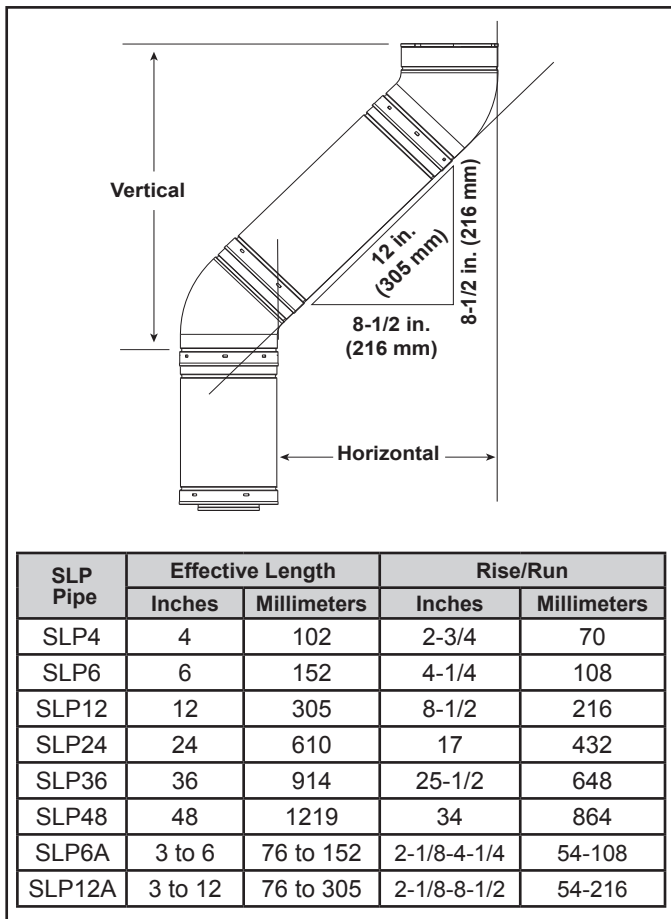

Figure 4.4

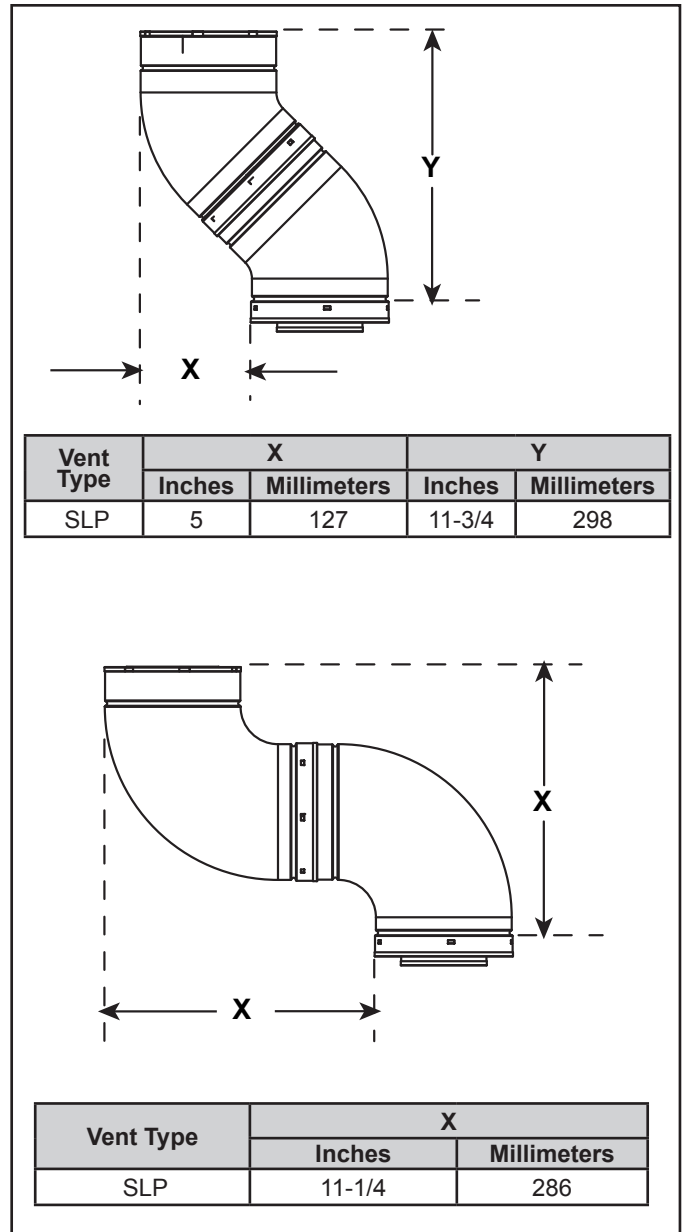

Figure 4.5 Vertical and Horizontal Offset for SLP Elbows

E. Measuring Standards

Vertical and horizontal measurements listed in the vent diagrams were made using the following standards:

- Pipe measurements are shown using the effective length of pipe. See Section 12.A (Figure 12.1) for information on effective length of pipe components.
- Horizontal terminations are measured to the outside mounting surface (flange of termination cap) (see Figure 4.6).
- Vertical terminations are measured to top of last section of pipe. See Figure 4.7.
- Horizontal pipe installed level with no rise.

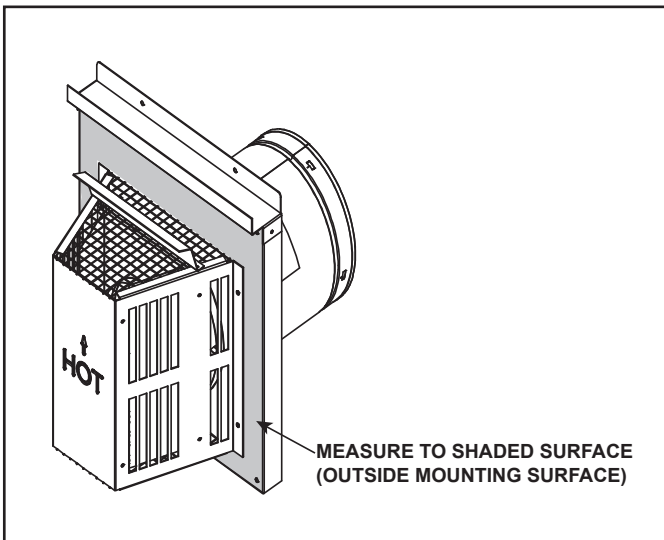

Figure 4.6 Measure to Outside Mounting Surface

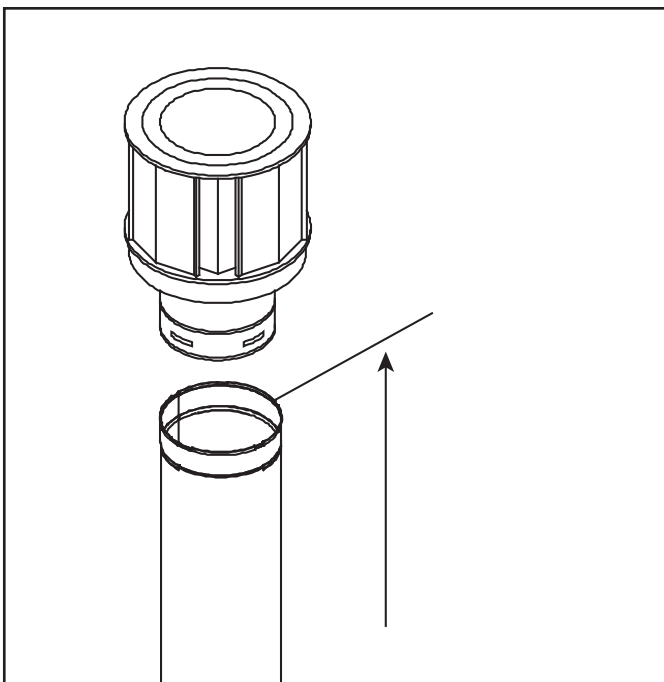

Figure 4.7 Measure to Top of Last Section of Pipe

F. Vent Diagrams

General Rules:

- Elbows may be placed back to back anywhere in the system.
- Any 90° elbow may be replaced with two back to back 45° elbows.
- When penetrating a combustible wall, a wall shield firestop must be installed.
- When penetrating a combustible ceiling, a ceiling firestop must be installed.
- Horizontal runs of vent do not require vertical rise; horizontal runs may be level.
- Horizontal termination cap should have a 1/4 in. (6 mm) downward slant to allow any moisture in cap to be released. See Figure 4.8.

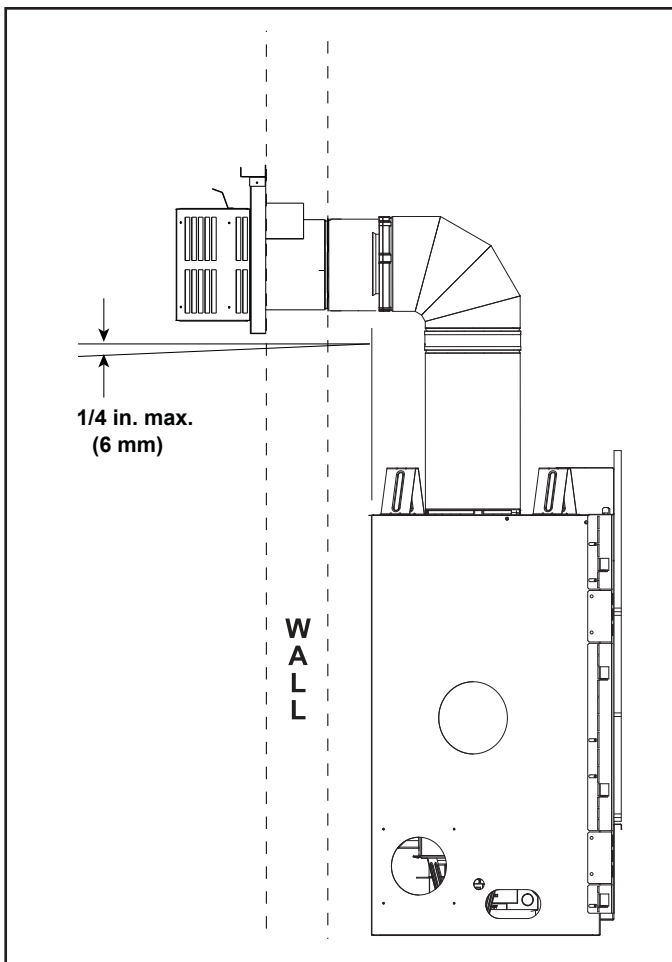

Figure 4.8 Vent Cap

Top Vent - Horizontal Termination

One 90° Elbow

Note: Use SLP Series components only.

CAUTION: The SLP-HRC-SS termination caps are not approved for use with these models. May lead to elevated glass temperature that may cause tempered glass breakage.

V Minimum		H ₁ Maximum	
		B41L-AU	
90° Elbow		Not Allowed	
1 ft.	305 mm	1 ft.	305 mm
2 ft.	610 mm	5 ft.	1.5 m
3 ft.	914 mm	8 ft.	2.4 m
4 ft.	1.2 m	10 ft.	3.0 m
5 ft.	1.5 m	15 ft.	4.6 m
		H MAX. = 15 ft. (4.6 m) V + H MAX. = 40 ft. (12.2 m)	

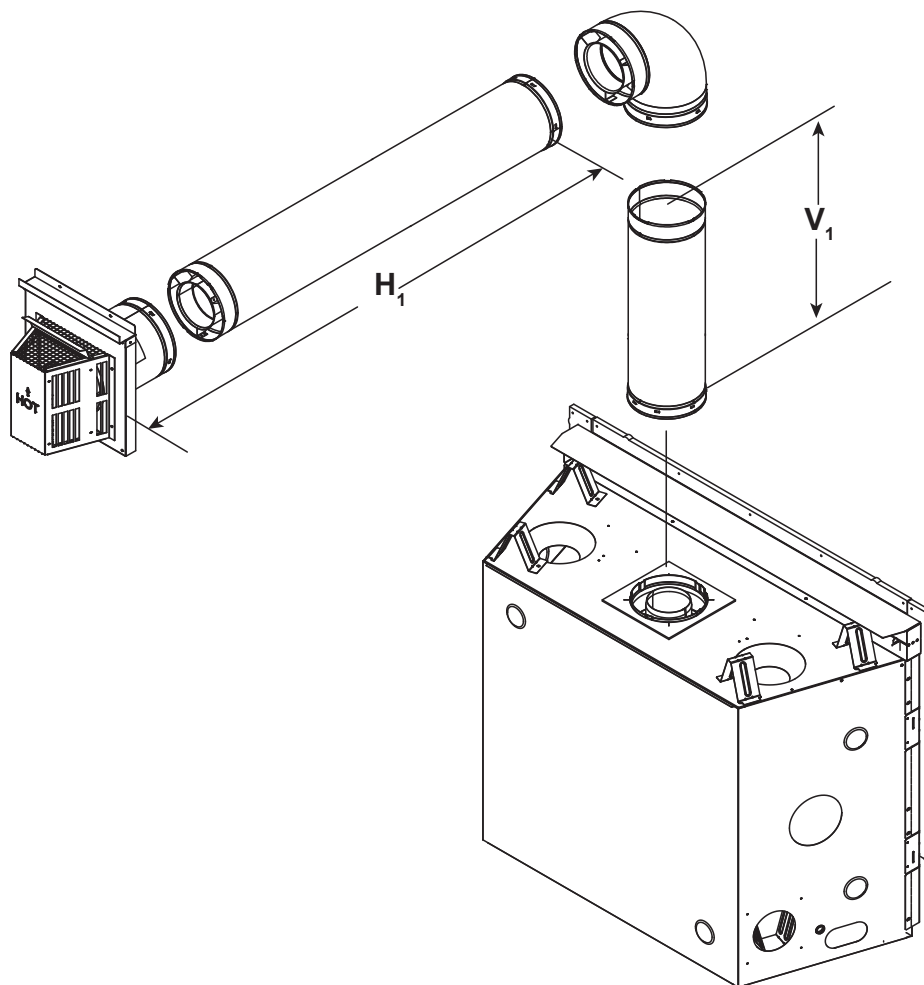

Figure 4.9

Top Vent - Horizontal Termination - (continued)

Two Elbows

Note: Use SLP Series components only.

CAUTION: The SLP-HRC-SS termination caps are not approved for use with these models. May lead to elevated glass temperature that may cause tempered glass breakage.

V Minimum		H ₁ + H ₂ Maximum	
		B41L-AU	
90° Elbow		Not Allowed	
1.5 ft.	457 mm	1 ft.	305 mm
2 ft.	610 mm	5 ft.	1.5 m
3 ft.	914 mm	8 ft.	2.4 m
4 ft.	1.2 m	10 ft.	3.0 m
5 ft.	1.5 m	15 ft.	4.6 m
H ₁ + H ₂ MAX. = 15 ft. (4.6 m) V ₁ + H ₁ + H ₂ MAX. = 40 ft. (12.2 m)			

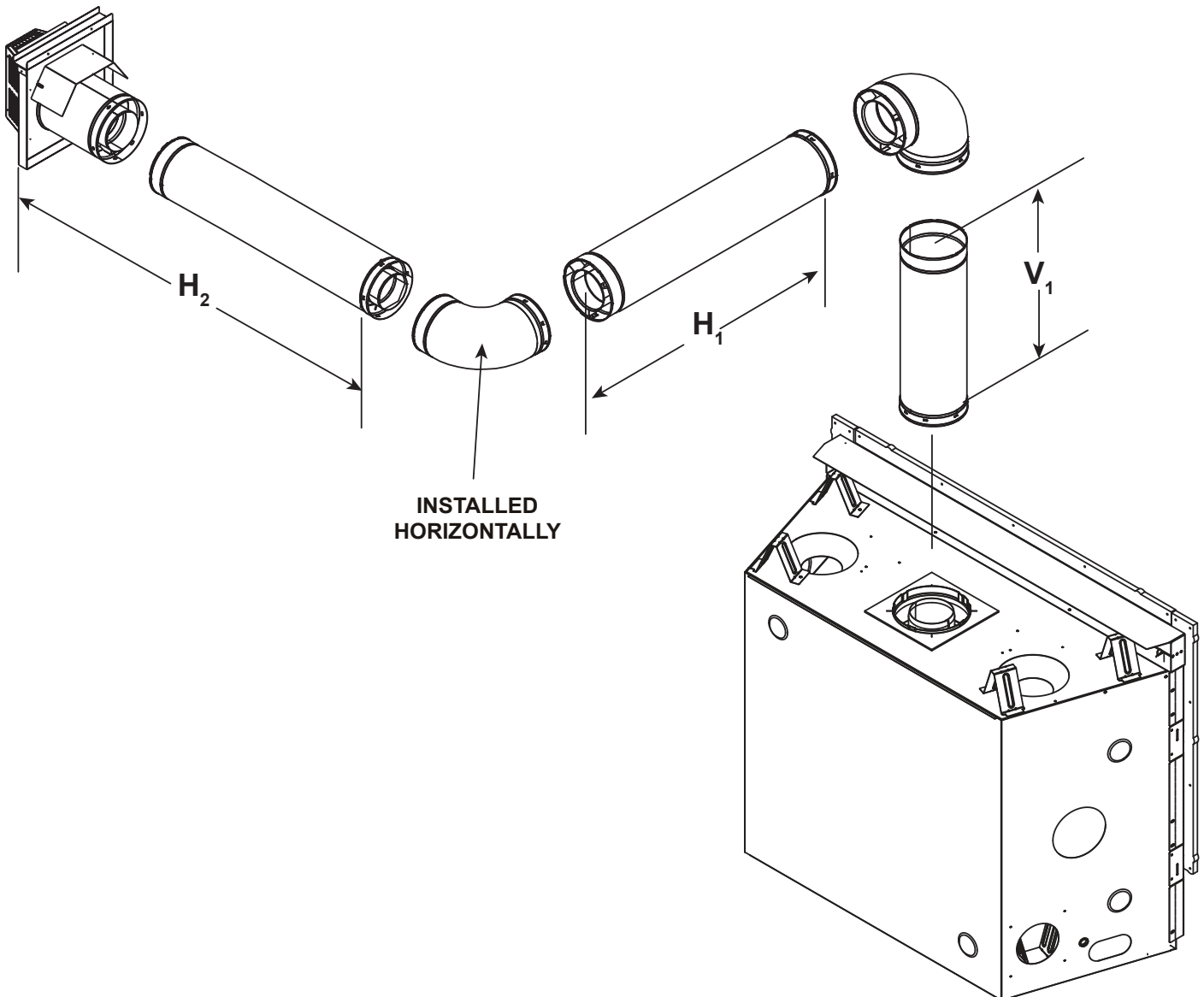

Figure 4.10

Top Vent - Horizontal Termination - (continued)

Three Elbows

Note: Use SLP Series components only.

B41L-AU					
V ₁ Minimum		H ₁ + H ₂ Maximum		V ₂	V ₁ + V ₂ Minimum
1.5 ft.	457 mm	6 ft.	1.8 m	*	*
2 ft.	610 mm	9 ft.	2.7 m	*	*
3 ft.	914 mm	14 ft.	4.3 m	*	*

$H_1 + H_2 \text{ MAX.} = 14 \text{ ft. (4.3 m)}$
 $V_1 + V_2 + H_1 + H_2 \text{ MAX.} = 40 \text{ ft. (12.2 m)}$
 *No specific restrictions on this value EXCEPT $V_1 + V_2 + H_1 + H_2$ cannot exceed 40 ft. (12.2 m)

CAUTION: The SLP-HRC-SS termination caps are not approved for use with these models. May lead to elevated glass temperature that may cause tempered glass breakage.

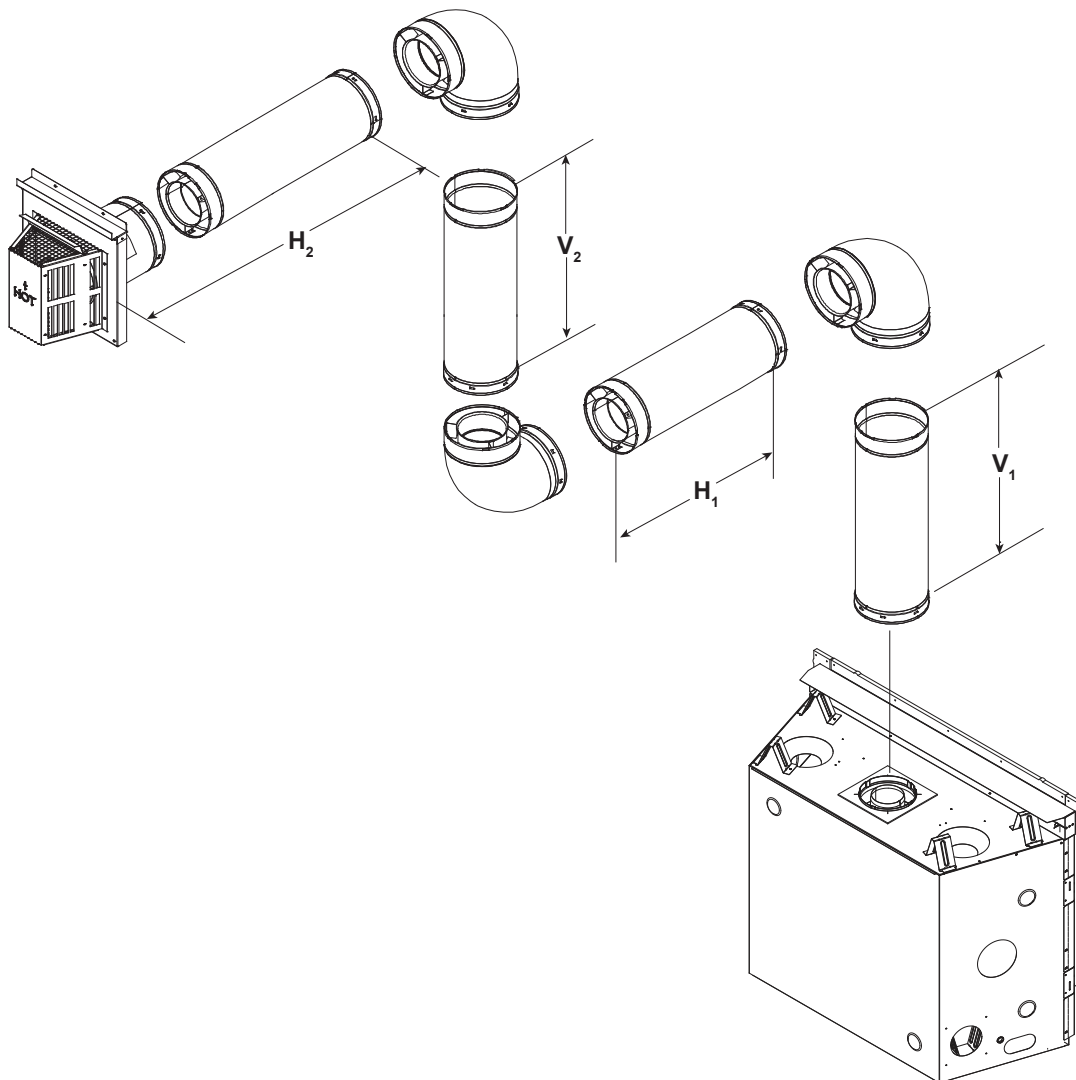

Figure 4.11

Top Vent - Horizontal Termination - (continued)

Three Elbows

WARNING *

Risk of Fire!
 This vent configuration can ONLY be used for B41L-AU Natural Gas appliances.

V Minimum		H ₁ + H ₂ + H ₃ MAXIMUM	
		B41L-AU (NG ONLY)	
4 ft.	1.2 m	15 ft.	4.6 m
H ₁ + H ₂ + H ₃ MAX. = 15 ft. (4.6 m) V ₁ MAX. = 7 ft (2.1 m)			

CAUTION: The SLP-HRC-SS termination caps are not approved for use with these models. May lead to elevated glass temperature that may cause tempered glass breakage.

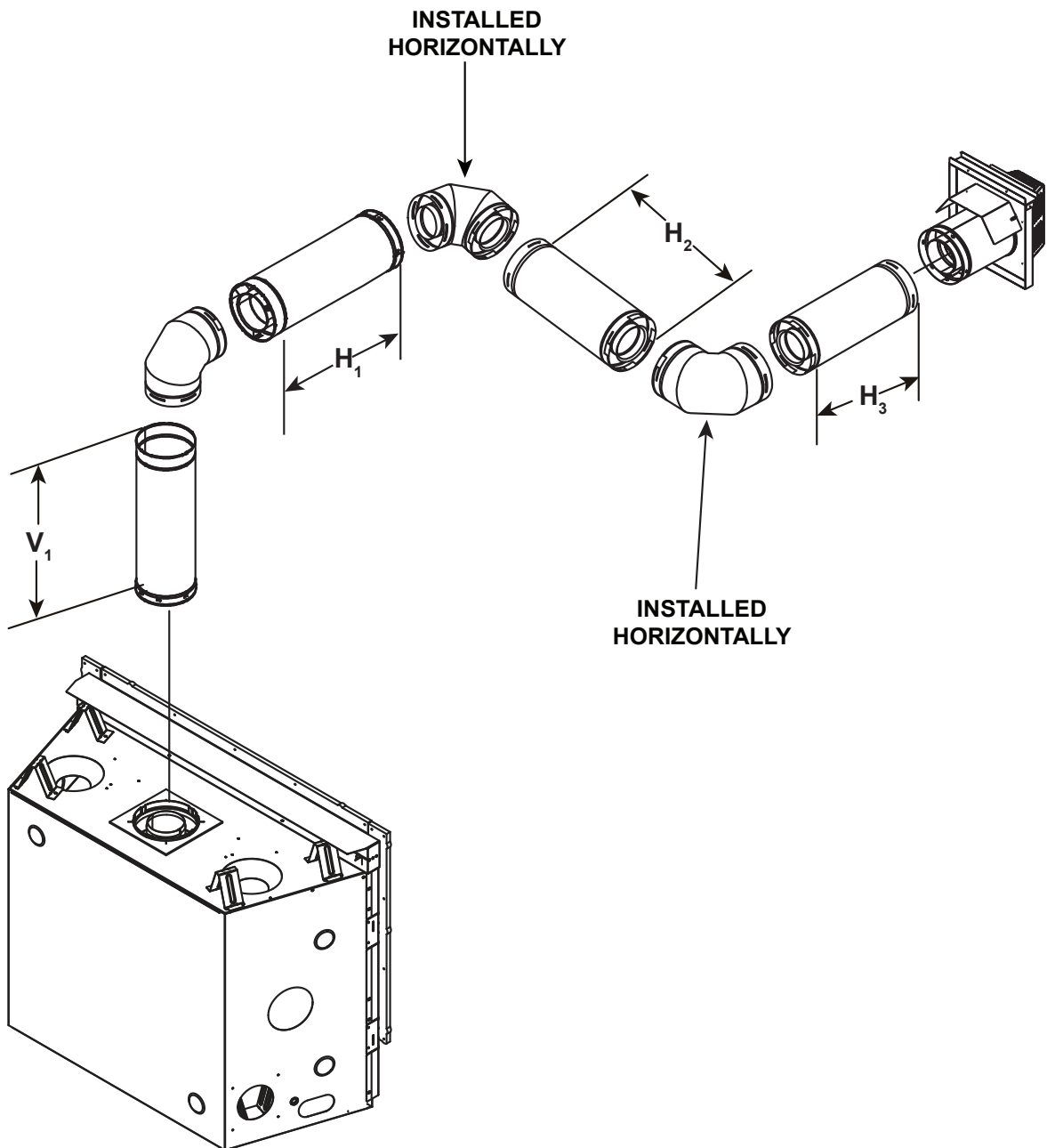

Figure 4.12

Top Vent - Vertical Termination

No Elbow

$V_1 = 60 \text{ ft. Max. (18.3 m)}$

Note: Use SLP Series components only.

Note: If installing a vertical vent/termination off the top of the appliance, the optional vertical termination baffle may be needed.

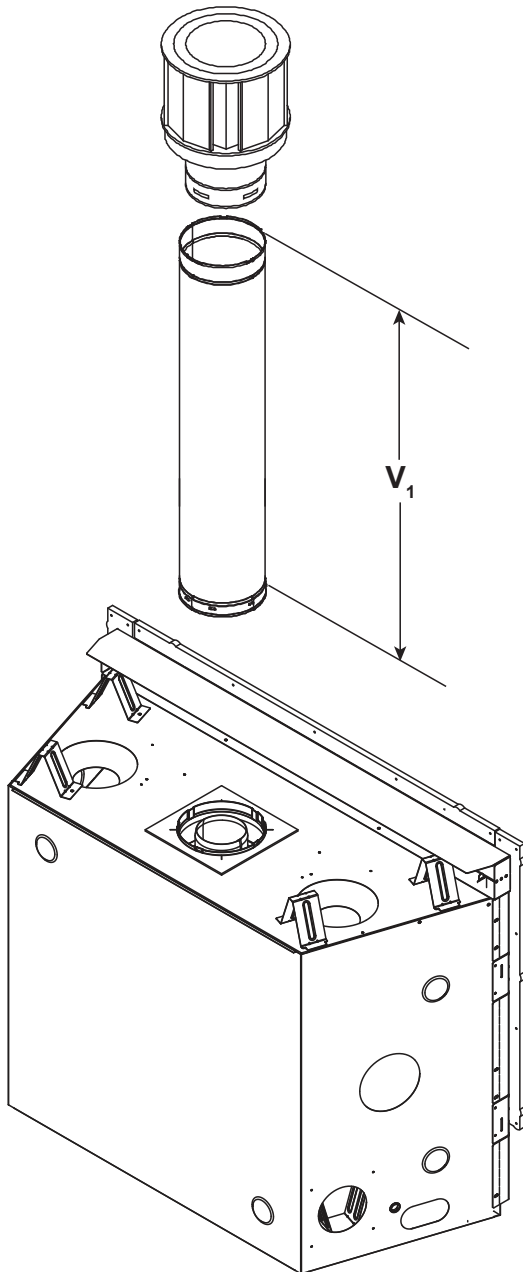

Figure 4.13

Exhaust Restrictor Instructions

Exhaust restrictors are recommended for these vertically terminated products which have excessive draft. Exhaust restrictors will compensate for high draft, and restore visual flame height. If the vent configuration has a total vertical of 15-60 feet (4.6-18.3 m), an exhaust restrictor may be needed. The exhaust restrictor can be located in the appliance manual bag.

1. Remove inner heat shield by removing two wing nuts from top front of heat shield and two screws that secure the heat shield to back wall of fireplace. Retain heat shield and fasteners.
2. Center the exhaust restrictor in the open end of the exhaust outlet and secure through the slots on the exhaust restrictor with the two 1/4 in (6 mm) self-tapping screws provided in the appliance manual bag. See Figure 4.14.
3. Reinstall shield by securing it with the two wing nuts and two screws previously removed in Step 1.

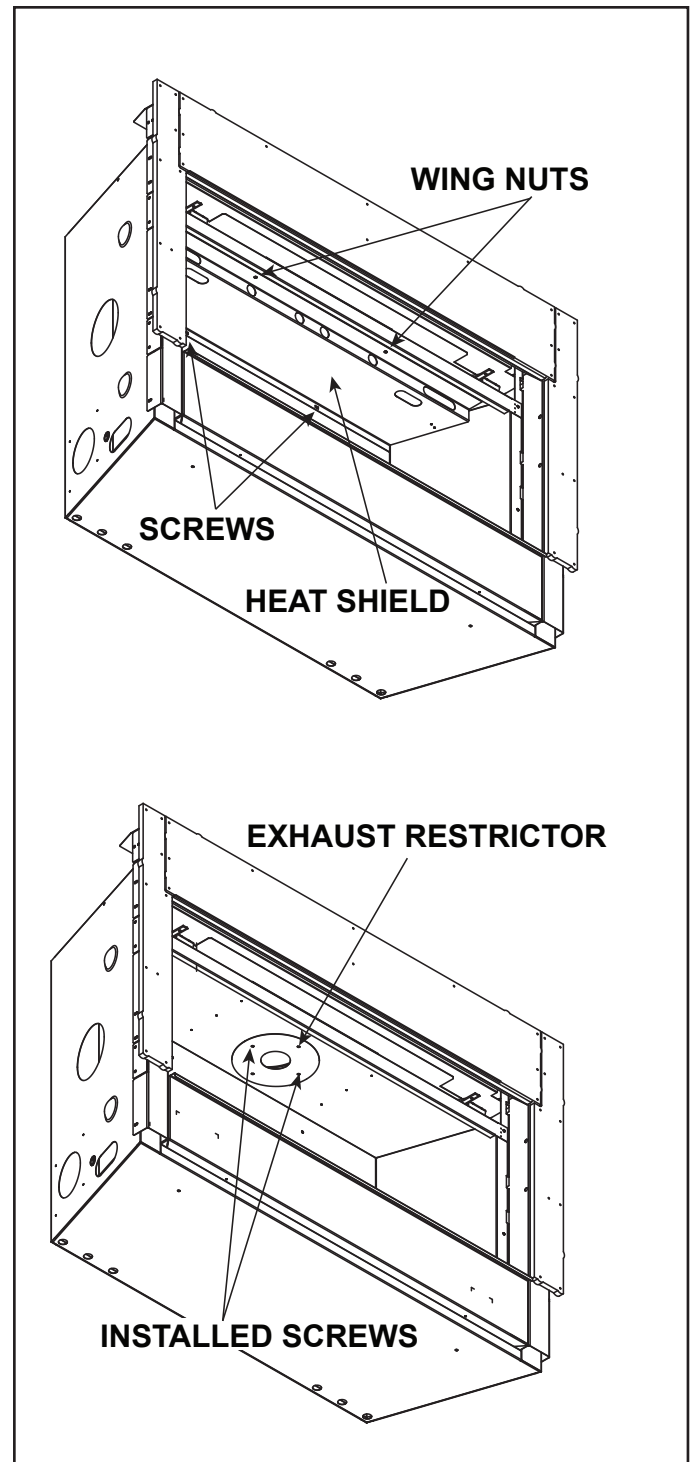

Figure 4.14

Top Vent - Vertical Termination - (continued)

Two 90° Elbows

Note: Use SLP Series components only.

B41L-AU					
V ₁ Minimum		H Maximum		V ₂	V ₁ + V ₂ Minimum
1 ft.	305 mm	2 ft.	610 mm	*	*
2 ft.	610 mm	3 ft.	914 mm	*	*
3 ft.	914 mm	5 ft.	1.5 m	*	*
4 ft.	1.2 m	7 ft.	2.1 m	*	*
5 ft.	1.5 m	15 ft.	4.6 m	*	*

H MAX. = 15 ft. (4.6 m)
V₁ + V₂ + H MAX. = 40 ft. (12.2 m)
* No specific restrictions on this value EXCEPT V₁ + V₂ + H cannot exceed 40 ft. (12.2 m)

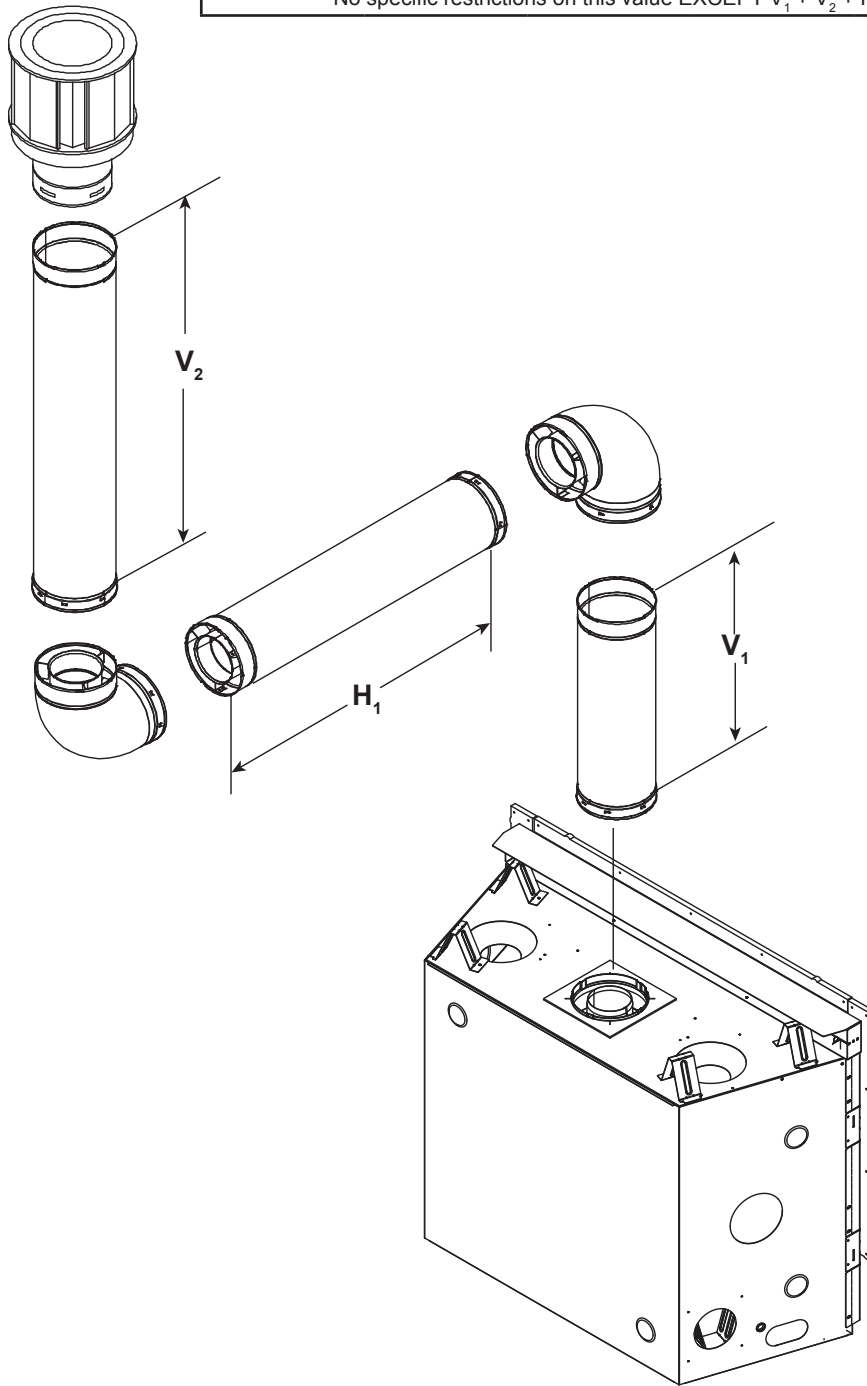

Figure 4.15

Top Vent - Vertical Termination - (continued)

Three 90° Elbows

Note: Use SLP Series components only.

B41L-AU					
V ₁ Minimum		H ₁ + H ₂ Maximum		V ₂	V ₁ + V ₂ Minimum
1 ft.	305 mm	1 ft.	305 mm	*	*
2 ft.	610 mm	2 ft.	610 mm	*	*
3 ft.	914 mm	4 ft.	1.2 m	*	*
4 ft.	1.2 m	6 ft.	1.8 m	*	*
5 ft.	1.5 m	14 ft.	4.3 m	*	*

H MAX. = 14 ft. (4.3 m)
V₁ + V₂ + H₁ + H₂ MAX. = 40 ft. (12.2 m)
* No specific restrictions on this value EXCEPT V₁ + V₂ + H₁ + H₂ cannot exceed 40 ft. (12.2 m)

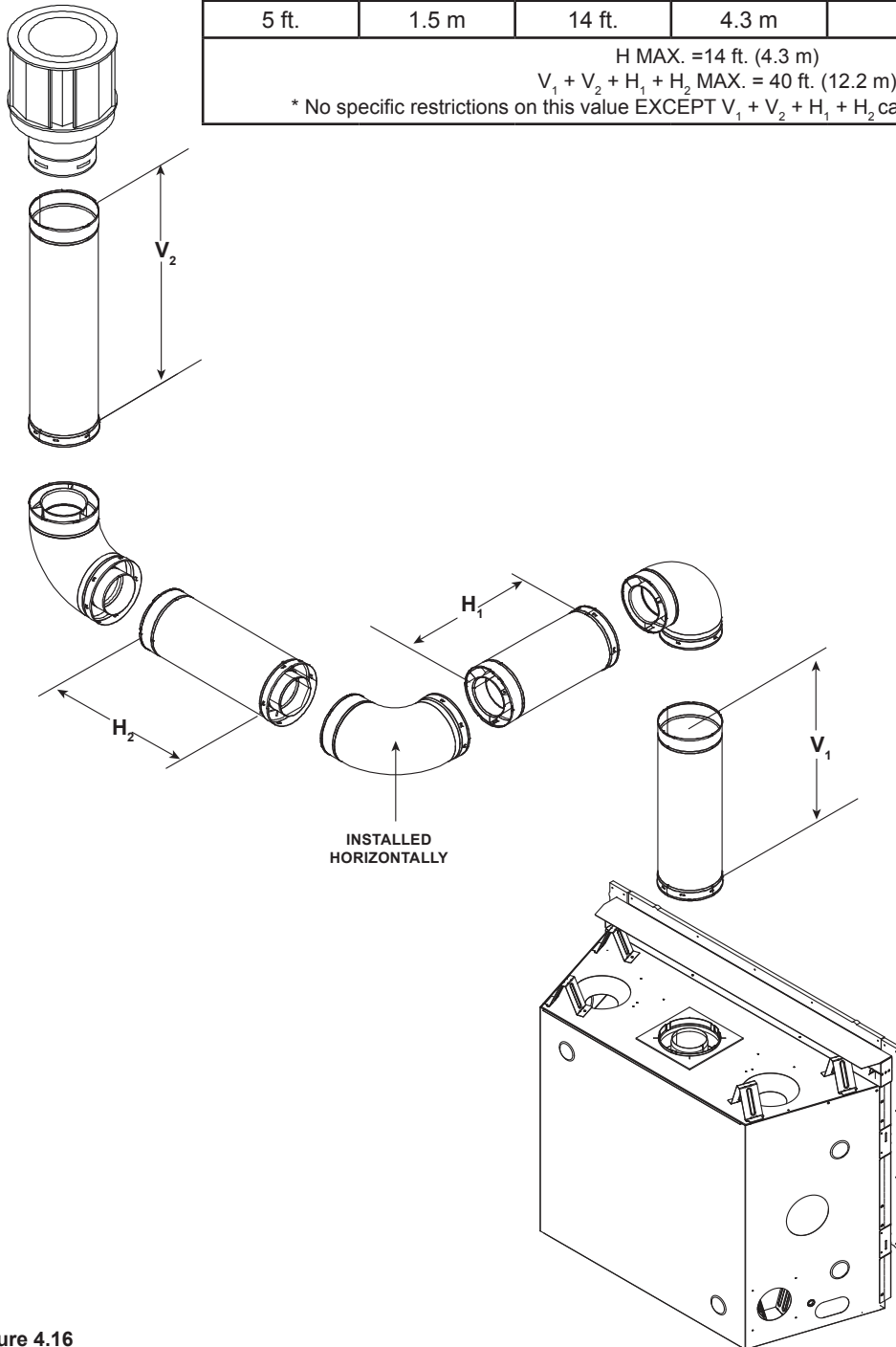

Figure 4.16

Top Vent - Vertical Termination - (continued)

Four 90° Elbows

Note: Use SLP Series components only.

B41L-AU									
V ₁ MIN.		H ₁ MAX.		V ₂ MIN.		H ₂ MAX.		V ₃ MIN.	
2-1/2 ft.	762 mm	4 ft.	1.2 m	4 ft.	1.2 m	4 ft.	1.2 m	3-1/2 ft.	1.0 m
$V_1 + V_2 + V_3 + H_1 + H_2$ Maximum = 40 ft. (12.2 m)									

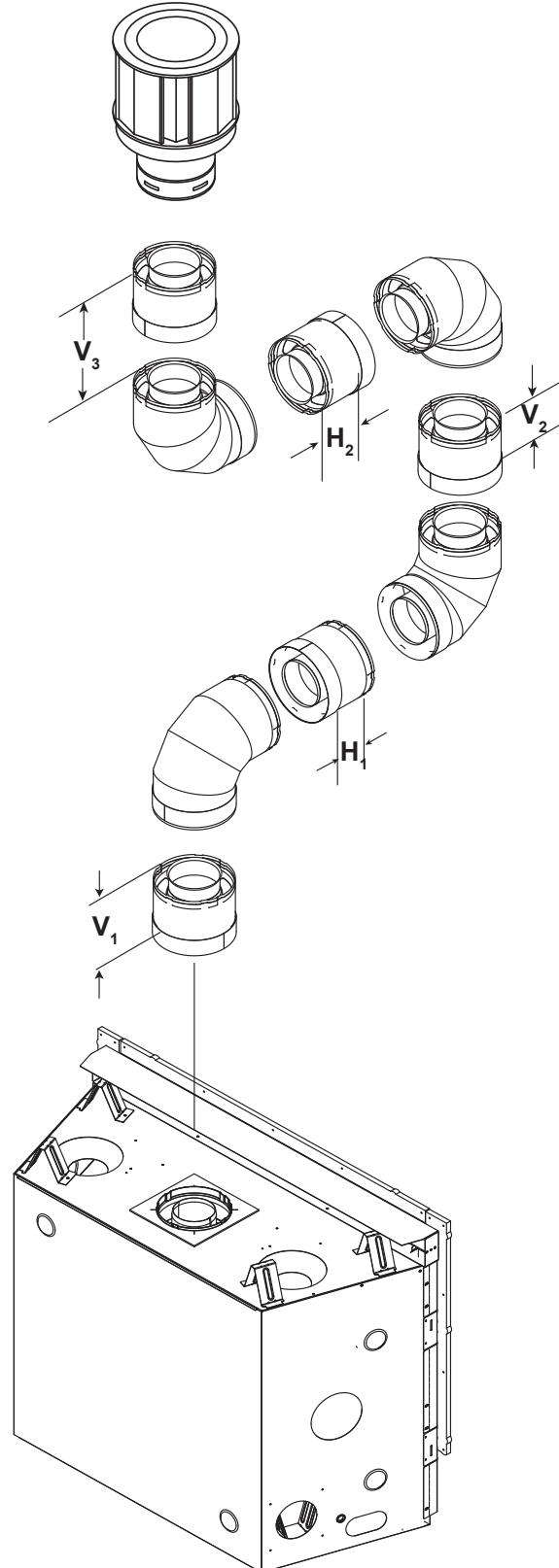

Figure 4.17

5 Vent Clearances and Framing

A. Pipe Clearances to Combustibles

WARNING! Risk of Fire! Maintain air space clearance to vent. DO NOT pack insulation or other combustibles:

- Between ceiling firestops
- Between wall shield firestops
- Around vent system

Failure to keep insulation or other material away from vent pipe could cause overheating and fire.

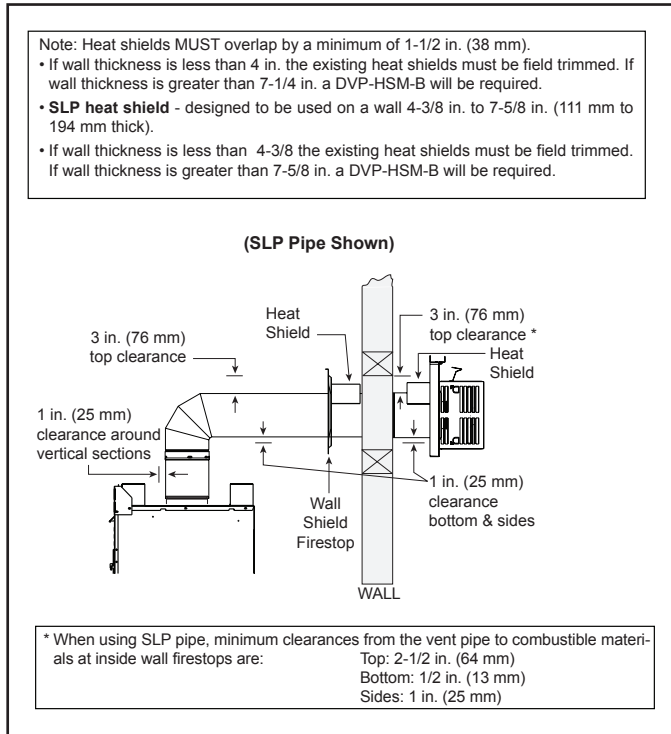

Figure 5.1 Horizontal Venting Clearances To Combustible Materials

B. Wall Penetration Framing/Firestops

Combustible Wall Penetration

Whenever a combustible wall is penetrated, you must frame a hole for the wall shield firestop(s). The wall shield firestop maintains minimum clearances and prevents cold air infiltration.

- The opening must be framed on all four sides using the same size framing materials as those used in the wall construction.
- SLP pipe - A wall shield firestop must be placed on each side of an interior wall. A minimum 1-1/2 in. (38 mm) overlap of attached heat shields must be maintained.
- See Section 7.F. for information for regarding the installation of a horizontal termination cap.

Non-Combustible Wall Penetration

If the hole being penetrated is surrounded by non-combustible materials such as concrete, a hole with diameter one inch greater than the pipe is acceptable.

Whenever a non-combustible wall is penetrated, the wall shield firestop is only required on one side and no heat shield is necessary.

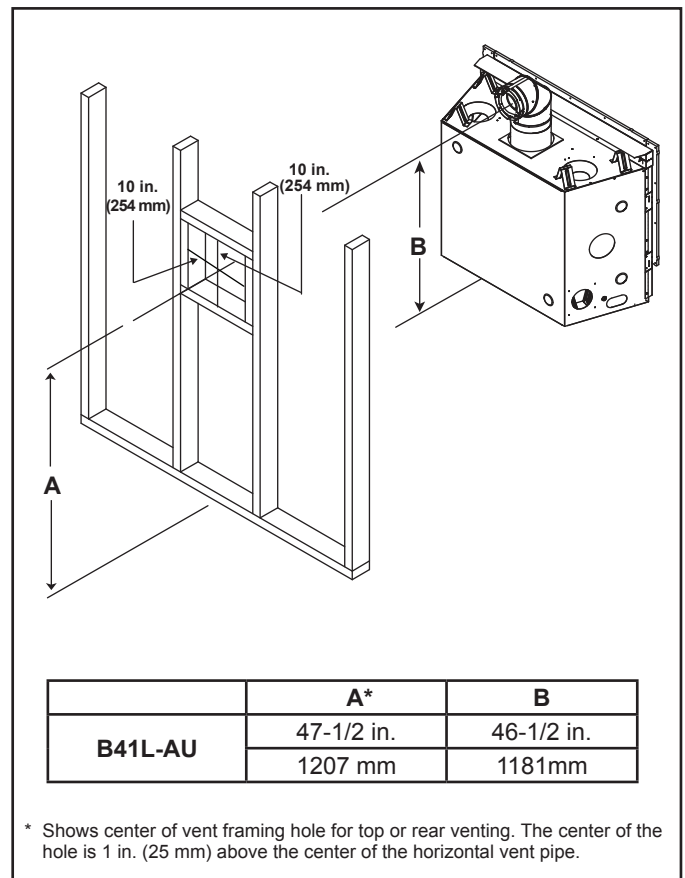

Figure 5.2 Wall Penetration

C. Ceiling Firestop/Floor Penetration Framing

A ceiling firestop **MUST** be used between floors and attics.

- **SLP pipe only** - Frame opening 9 in. x 9 in. (229 mm x 229 mm) whenever the vent penetrates a ceiling/floor (see Figure 5.3).
- Frame the area with the same sized lumber as used in ceiling/floor joist.
- The ceiling firestop may be installed above or below the ceiling joists when installed with an attic insulation shield. It must be under joists between floors that are not insulated. Refer to Figure 5.4.
- Secure in place with nails or screws.

WARNING! Risk of Fire! DO NOT pack insulation around the vent. Insulation must be kept back from the pipe to prevent overheating.

D. Install Attic Insulation Shield

WARNING! Fire Risk. DO NOT allow loose materials or insulation to touch vent. Hearth & Home Technologies requires the use of an attic shield.

The International Fuel Gas Code requires an attic shield constructed of 26 gauge minimum steel that extends at least 2 in. (51 mm) above insulation.

- Attic insulation shields must meet specified clearances to combustible materials and be secured in place.
- An attic insulation shield kit is available from Hearth & Home Technologies. Contact your dealer to order. Install attic insulation shield according to instructions included with kit.

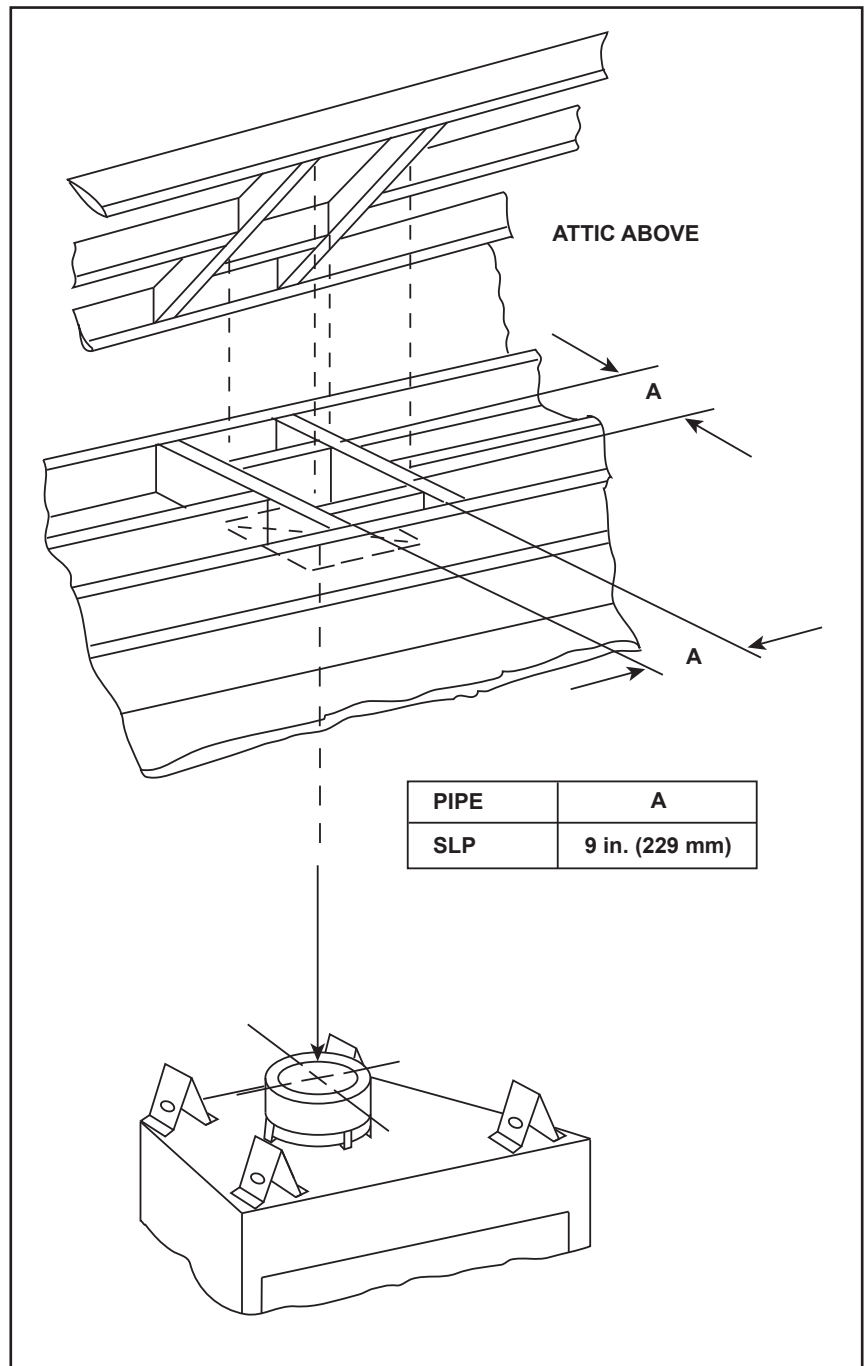

Figure 5.3 Installing Ceiling Firestop

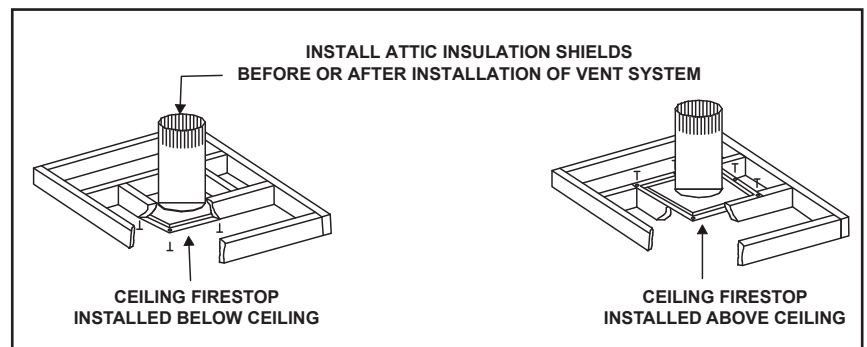

Figure 5.4 Installing the Attic Shield

6 Appliance Preparation

A. Vent Collar Preparation

CAUTION! Risk of Cuts, Abrasions or Flying Debris. Wear protective gloves and safety glasses during installation. Sheet metal edges are sharp.

Top Vent

WARNING! Risk of Fire! Do not remove heat shield. Elevated header temperatures may cause a fire.

1. Remove two screws and discard. See Figure 6.1.
2. Fold up top heat shield to 90 degrees as shown in Figure 6.2.

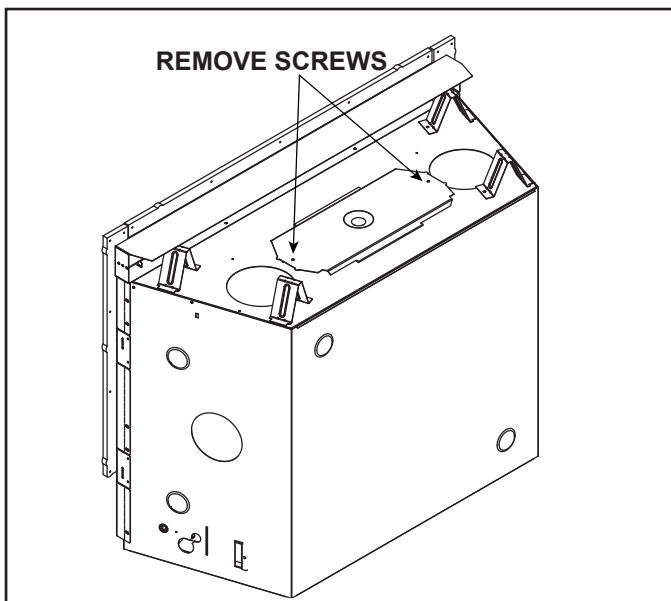

Figure 6.1 Shipping Position

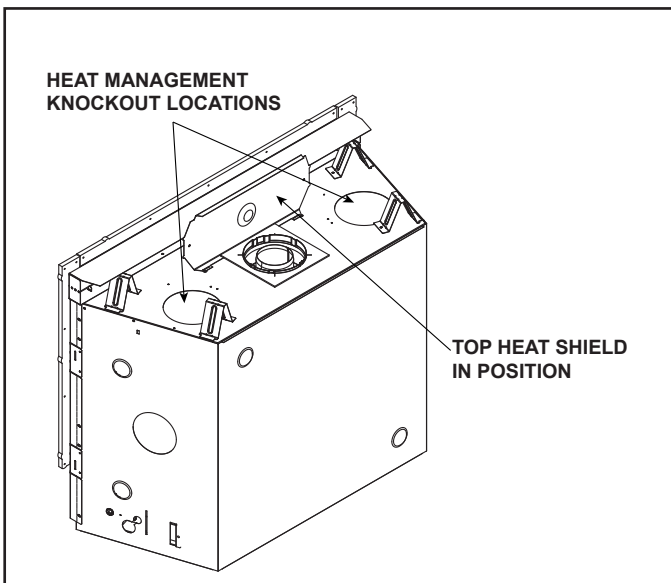

Figure 6.2 Top Heat Shield in Position and Heat-Zone®-240V Gas Locations

B. Prepare For Heat Management

Introduction

An optional heat management system allows the heat from the appliance to be redirected as desired.

An optional heat management system must be installed by a qualified service technician at the time of the appliance installation. Follow the instructions shipped with the kit for installation and operation.

NOTICE: Additional clearances are required for heat management systems installations. Provisions must be made in advance to ensure fit within the framing.

- Determine the heat management system(s) that will be installed.
- Locate the two heat management ports on the top of the appliance. Either one or two Heat-Zone®-240V Gas Kits may be installed. See Figure 6.2. Remove the knockouts from the appliance with a tin snips.
- Center the duct collar or passive heat adapter around the exposed hole and attach it to the appliance. See Figure 6.3.

Note: Do this BEFORE final positioning of the appliance.

- Determine the location for the air register/fan housing assembly.

Reference the Heat-Zone®- 240V Gas Kit or Passive Heat instructions for the remaining installation steps.

Heat Management System options are:

- HEAT-ZONE®- 240V Gas Kit: The heat is diverted into an adjacent room.
- Passive Heat (PH-FRT, PH-SIDE): The heat is vented into the room in which the appliance is installed through a discharge opening(s).

WARNING! Risk of Fire! DO NOT block passive heat registers! Overheating of appliance and combustible materials will occur.

WARNING! Risk of Fire! DO NOT remove a knockout unless a heat management system will be installed in its place. Appliance and combustible materials will overheat.

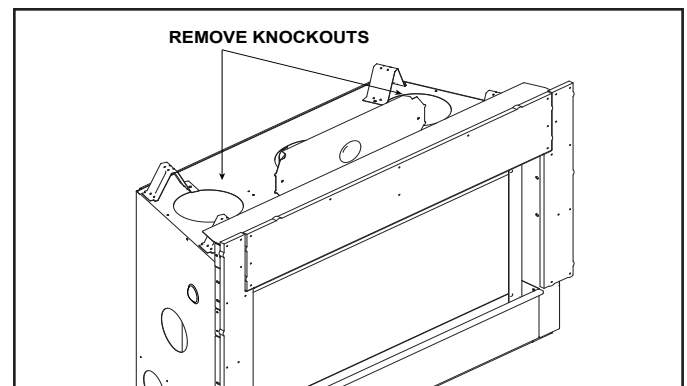

Figure 6.3 Remove Heat Management Knockouts

C. Securing and Leveling the Appliance

⚠ WARNING



Risk of Fire!

Prevent contact with:

- *Sagging or loose insulation*
- *Insulation backing or plastic*
- *Framing and other combustible materials*

DO NOT remove standoffs or notch the framing around the appliance standoffs.

Failure to maintain air space clearance could cause overheating and fire.

Block openings into the chase to prevent entry of blown-in insulation. Make sure insulation and other materials are secured.

Figure 6.4 shows how to properly position and secure the appliance. Nailing tabs are provided to secure the appliance to the framing members.

- Bend out nailing tabs on each side.
- Place the appliance into position.
- Keep nailing tabs flush with the framing.
- Level the appliance from side to side and front to back.
- Shim the appliance as necessary. It is acceptable to use wood shims underneath the appliance.
- Secure the appliance to the framing by using nails or screws through the nailing tabs. Use a minimum of one fastener per nailing tab.
- Optional: Secure the appliance to the floor by inserting two screws through the pilot holes at the bottom of the appliance.

The B41L-AU model ships with factory-installed non-combustible board. This board must be used. Do NOT remove. See Figure 6.4.

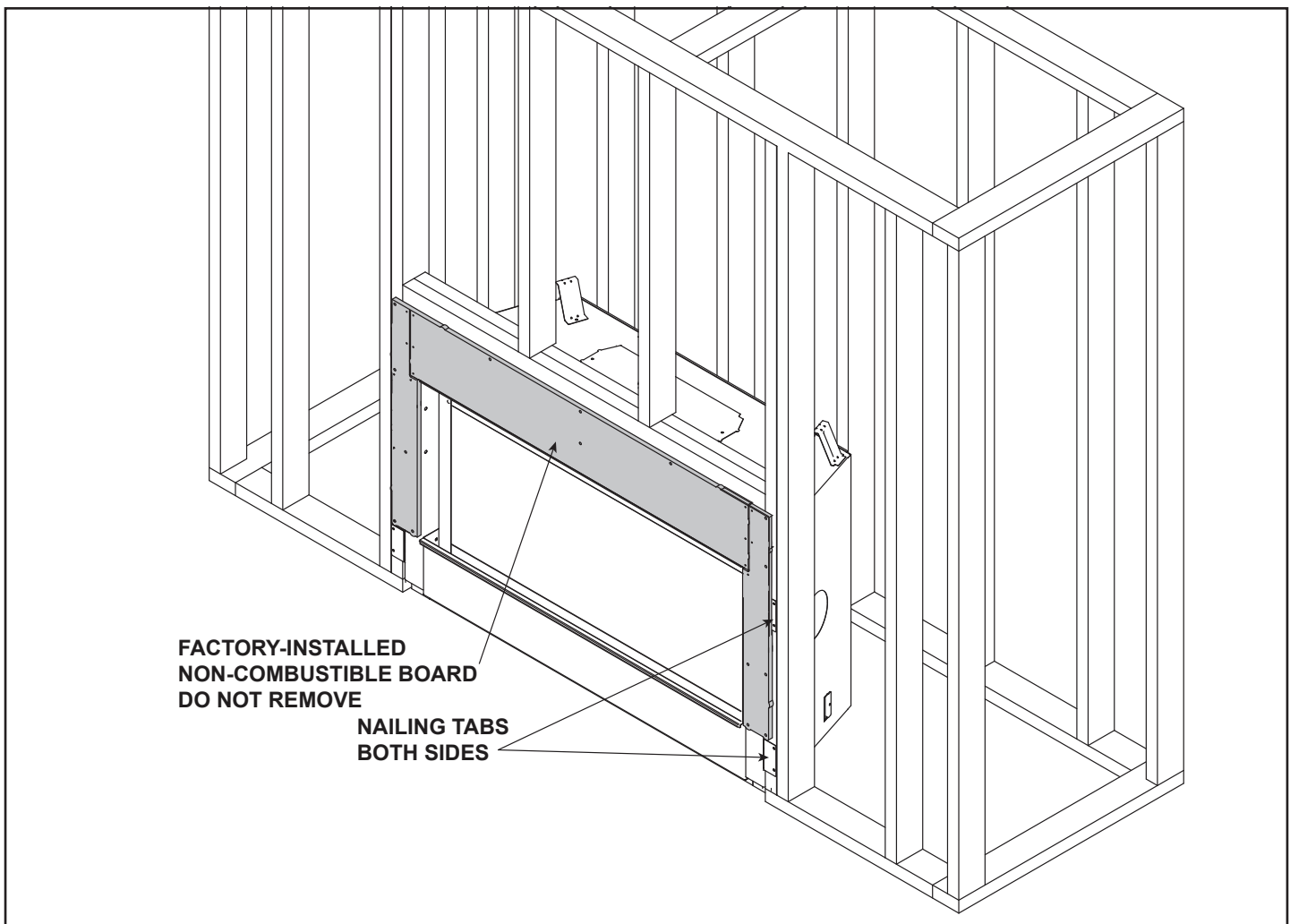

Figure 6.4 Proper Positioning, Leveling And Securing Of Appliance

D. Non-Combustible Material Installation

WARNING! Risk of Fire! DO NOT remove factory-installed non-combustible material.

This model ships with the required top, left and right non-combustible board. The top non-combustible board has been pre-installed at the factory with three screws. The left and right side non-combustible boards are shipped in the cardboard splatter guard in front of the appliance. See Figure 6.5.

1. Remove the left and right non-combustible components from the shipping position and set aside.
2. Remove the lower cover panel by removing two screws located on the lower left and right sides of the appliance opening. Retain screws. Lift the lower cover panel “up” and “out” to remove.
3. Locate the manual bag assembly and remove the small package containing the 1-1/2 in. (38 mm) Phillips screws.

Note: Care should be taken when installing screws into the non-combustible board. DO NOT overtighten screws. Screws should be set “flush” to the surface of the non-combustible board.

4. Further secure the top non-combustible board by installing screws into the pilot holes located in the lower left and right corners as shown in Figure 6.6.
5. Install the left and right non-combustible components with four of the provided Phillips screws. See Figure 6.6.
6. Install drywall screws (not provided) around the perimeter of the installed non-combustible components to secure it to the framing material. Refer to Section 10 for more information.

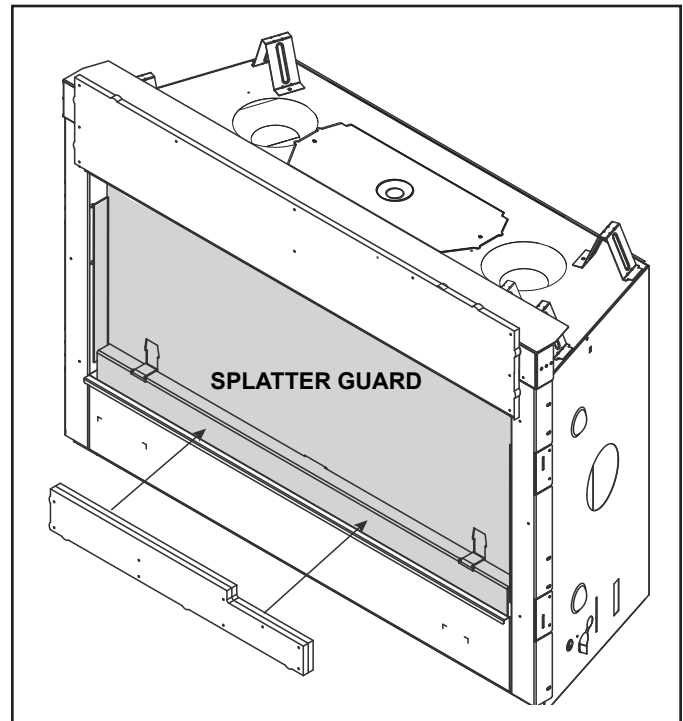

Figure 6.5 Shipping Position - Non-Combustible Sides

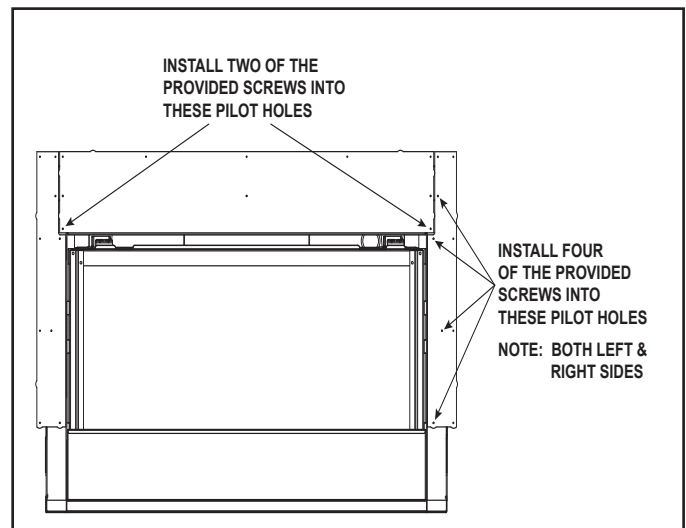

Figure 6.6 Proper Positioning, Leveling And Securing Of Appliance

7 Venting and Chimneys

A . Assemble Vent Sections (SLP Only)

To attach the first vent component to the starting collars of the appliance:

- Lock the vent components into place by sliding the pipe section onto the collar.
- Align the seam of the pipe and seam of collar to allow engagement. Rotate the vent component to lock into place. Use this procedure for all vent components. See Figure 7.2.
- Slide the gasket over the first vent section and place it flush to the appliance. This will prevent cold air infiltration. Caulk with a minimum of 300 °F (149 °C) continuous exposure rating may be used to hold the part in place.
- Continue adding vent components, locking each succeeding component into place.
- Ensure that each succeeding vent component is securely fitted and locked into the preceding component.

It is acceptable to use screws no longer than 1/2 in. (13 mm) to hold outer pipe sections together. If predrilling holes, **DO NOT** penetrate inner pipe.

Requirement for Commercial, Multi-family (Multi-level exceeding two stories), or High-Rise Applications

All outer pipe joints must be sealed using one of the methods below, including the slip section that connects directly to the horizontal termination cap.

- Apply a bead of silicone sealant (300 °F (149 °C) minimum continuous exposure rating) inside the female outer pipe joint prior to joining sections. See Figure 7.1 **OR**

Apply a bead of silicone sealant (300 °F (149 °C) minimum continuous exposure rating) to the outside of connecting joint after joining sections **OR**

Apply aluminum foil tape (300 °F minimum continuous exposure rating) to the outside of connecting joint after joining sections. On horizontal pipe runs, it is recommended that the tape seam is positioned on the bottom side of the vent pipe.

- Only outer pipes need to be sealed. All unit collar, pipe, slip section, elbow and cap outer flues shall be sealed in this manner, unless otherwise stated.



Figure 7.1 High Temperature Silicone Sealant

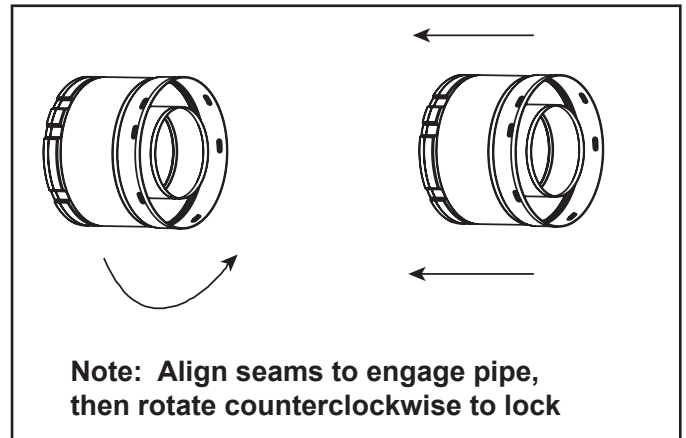

Figure 7.2 Adding Venting Components

B. Assemble Slip Sections

- Slide the inner flue of the slip section into the inner flue of the pipe section and the outer flue of the slip section over the outer flue of the pipe section. See Figure 7.3.
- Slide together to the desired length.

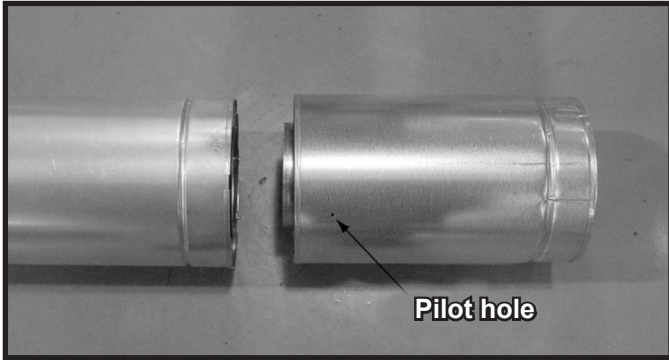

Figure 7.3 Slip Section Pilot Holes

- Maintain a 1-1/2 in. (38 mm) overlap between the slip section and the pipe section.
- Secure the pipe and slip section with two screws no longer than 1/2 in. (13 mm), using the pilot holes in the slip section. See Figure 7.4.

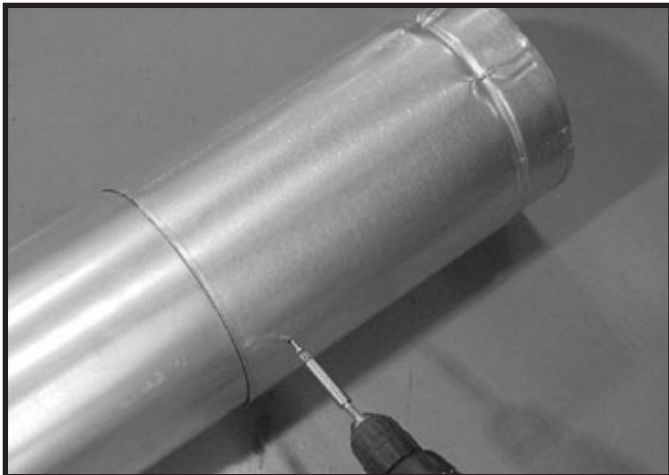

Figure 7.4 Screws into Slip Section

- Continue adding pipe as necessary following instructions in “Assembling Pipe Sections.”

NOTICE: If slip section is too long, the inner and outer flues of the slip section can be cut to the desired length.

C. Secure the Vent Sections

- Vertical runs originating off the top of the appliance, with no offsets, must be supported every 8 ft. (2.44 m) after the maximum allowed 25 ft. (7.62 m) of unsupported rise.
- Vertical runs originating off the rear of the appliance, or after any elbow, must be supported every 8 ft. (2.44 m).
- Horizontal runs must be supported every 5 feet (1.52 m).
- Vent supports or plumbers strap (spaced 120° apart) may be used to support vent sections. See Figures 7.5 and 7.6.
- Wall shield firestops may be used to provide horizontal support to vent sections.
- SLP ceiling firestops have tabs that may be used to provide vertical support.

WARNING! Risk of Fire, Explosion or Asphyxiation! Improper support could allow vent to sag and separate. Use vent run supports and connect vent sections per installation instructions. **DO NOT** allow vent to sag below connection point to appliance.

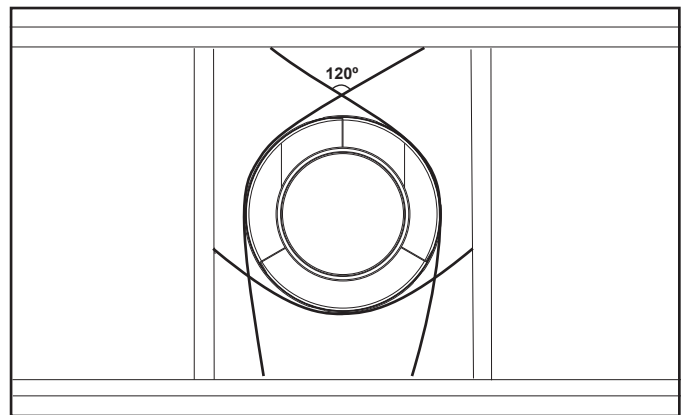

Figure 7.5 Securing Vertical Pipe Sections

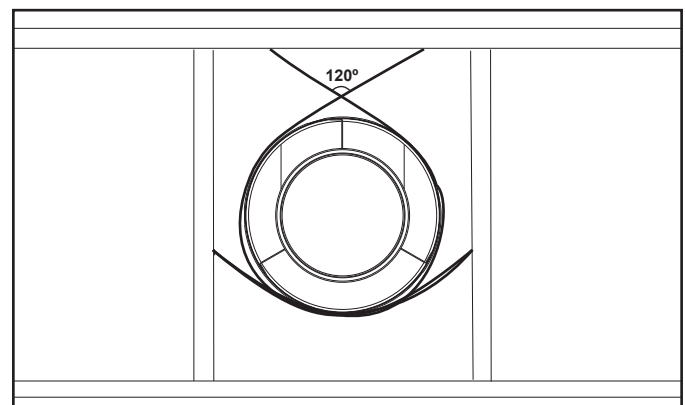

Figure 7.6 Securing Horizontal Pipe Sections

D. Disassemble Vent Sections

- Rotate either section (see Figure 7.7) so the seams on both pipe sections are aligned as shown in Figure 7.8.
- Pull carefully to separate the pieces of pipe.

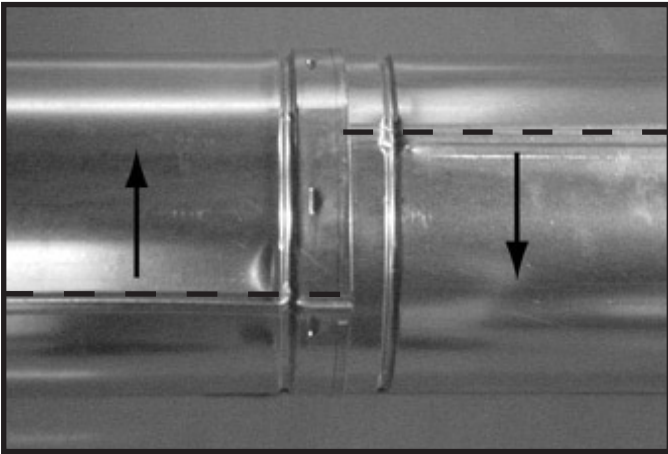

Figure 7.7 Rotate Seams for Disassembly

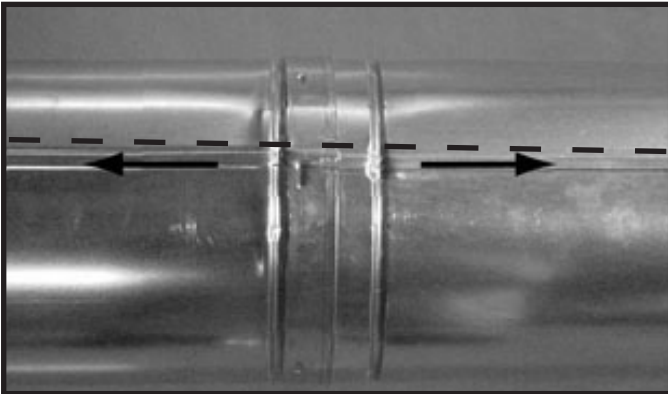

Figure 7.8 Align and Disassemble Vent Sections

E. Vertical Termination Requirements

Install and Seal Metal Roof Flashing

- See minimum vent heights for various pitched roofs (Section 4, Figure 4.1) to determine the length of pipe to extend through the roof.
- Slide the roof flashing over the pipe sections extending through the roof as shown in Figure 7.9.
- Use an elastomeric or silicone sealant with a minimum of 150 °F temperature rating to seal the metal roof flashing.

NOTICE: Failure to properly seal the roof flashing and pipe seams could permit entry of water.

- Seal the gap between the roof flashing and the outside diameter of the pipe.
- Seal the perimeter of the flashing where it contacts the roof surface. See Figure 7.9.
- Seal the exposed pipe section seams that are located above the roof.

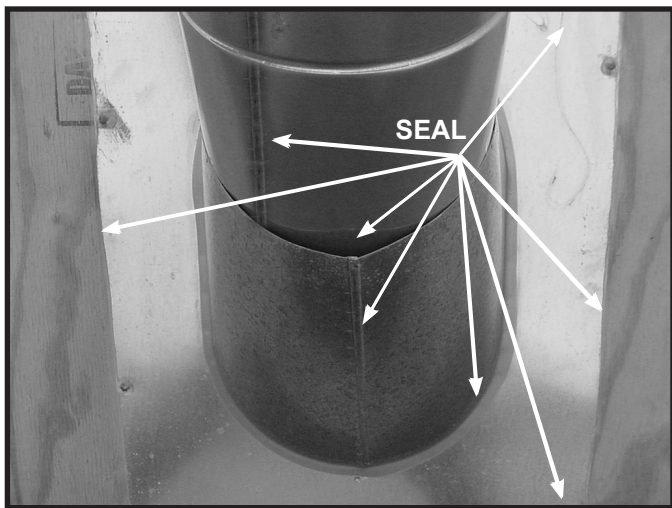

Figure 7.9

Assemble and Install Storm Collar

CAUTION! Risk of Cuts, Abrasions or Flying Debris. Wear protective gloves and safety glasses during installation. Sheet metal edges are sharp.

- Slide the storm collar onto the exposed pipe section and align brackets.
- Insert a bolt (provided) through the brackets and install nut. Do not completely tighten.



Figure 7.10 insert Bolt into Brackets

- Slide the assembled storm collar down the pipe section until it rests on the roof flashing. See Figure 7.10.
- Tighten nut and make sure the collar is tight against the pipe section.
- Seal around the top of the storm collar. See Figure 7.11.

Install Vertical Termination Cap

- Attach the vertical termination cap by sliding the inner collar of the cap into the inner flue of the pipe section while placing the outer collar of the cap over the outer flue of the pipe section.
- Secure the cap by driving three self-tapping screws (supplied) through the pilot holes in the outer collar of the cap into the outer flue of the pipe. See Figure 7.11.

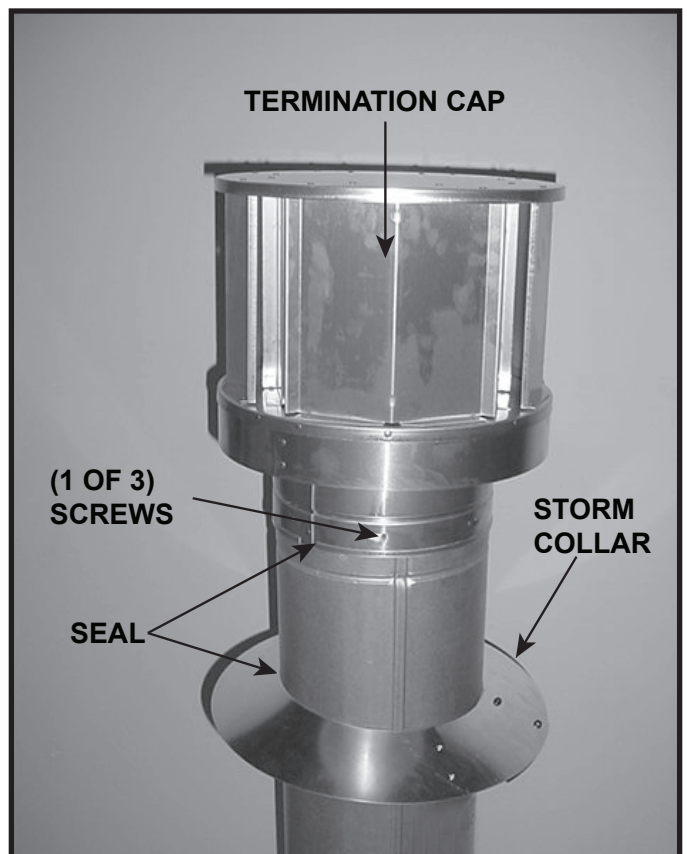

Figure 7.11

F. Horizontal Termination Requirements

Heat Shield Requirements for Horizontal Termination

WARNING! Risk of Fire! To prevent overheating and fire, heat shields must extend through the entire wall thickness.

- **DO NOT** remove the heat shields attached to the wall shield firestop and the horizontal termination cap (shown in Figure 7.12).
- Heat shields must overlap 1-1/2 in. (38 mm) minimum.

There are two sections of the heat shield. One section is factory-attached to the wall shield firestop. The other section is factory-attached to the cap. See Figure 7.12.

If the wall thickness does not allow the required 1-1/2 in. (38 mm) heat shield overlap when installed, an extended heat shield must be used.

- If the wall thickness is less than 4 in./102 mm (DVP) or 4-3/8 in./ 111 mm (SLP), the heat shields on the cap and wall shield firestop must be trimmed. A minimum 1-1/2 in. (38 mm) overlap **MUST** be maintained.
- Use an extended heat shield if the finished wall thickness is greater than 7-1/4 in. (184 mm).
- The extended heat shield may need to be cut to length maintaining sufficient length for a 1-1/2 in. (38 mm) overlap between heat shields.
- Attach the extended heat shield to either of the existing heat shields using the screws supplied with the extended heat shield. Refer to vent components diagrams in the back of this manual.
- Rest the small leg on the extended heat shield on top of the pipe section to properly space it from the pipe section.

Important Notice: Heat shields may not be field constructed.

Install Horizontal Termination Cap (SLP Pipe)

WARNING! Risk of Fire! The telescoping flue section of the termination cap **MUST** be used when connecting vent.

- 1-1/2 (38 mm) minimum overlap of flue telescoping section is required.

Failure to maintain overlap could cause overheating and fire.

- Vent termination must not be recessed in the wall. Siding may be brought to the edge of the cap base.
- Flash and seal as appropriate for siding material at outside edges of cap.
- When installing a horizontal termination cap, follow the cap location guidelines as prescribed by current local or national codes and refer to Section 4 of this manual.

CAUTION! Risk of Burns! Local codes may require installation of a cap shield to prevent anything or anyone from touching the hot cap.

Note: When using termination caps with factory-supplied heat shield attached, no additional wall shield firestop is required on the exterior side of a combustible wall.

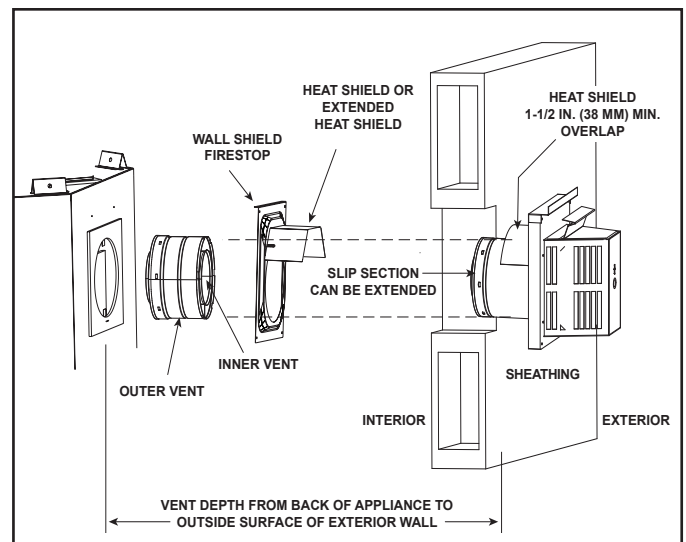

Figure 7.12 Venting Through the Wall

8 Electrical Information

A. General Information

WARNING! Risk of Shock or Explosion! DO NOT wire 220/240 VAC to the valve or to the appliance wall switch. Incorrect wiring will damage controls.

- Wire the appliance junction cord to unswitched 220/240 VAC. This is required for proper operation of the appliance.
- A 220/240 VAC circuit for this product must be protected with ground-fault circuit-interrupter protection, in compliance with the applicable electrical codes, when it is installed in locations such as in bathrooms or near sink.
- Low voltage and 220/240 VAC voltage cannot be shared within the same wall box.

Electrical Service and Repair

WARNING! Risk of Shock! Label all wires prior to disconnection when servicing controls. Wiring errors can cause improper and dangerous operation. Verify proper operation after servicing.

WARNING! Risk of Shock! Replace damaged wire with type 105 °C rated wire. Wire must have high temperature insulation.

Valve/Control Access

The valve/control cavity is accessible, by removing two screws located in the lower right and left corners of the fireplace opening. See Figure 8.1.

Once finish material has been installed access to the valve/control cavity is limited to access through the fire-box, see Section 9.C.

Accessories Requirements

- This appliance may be used with a wall switch, wall mounted thermostat and/or a remote control.

Wiring for optional Hearth & Home Technologies approved accessories should be done now to avoid reconstruction. Follow instructions that come with those accessories.

Junction Cord Installation

WARNING! Risk of Shock! Label all wires prior to disconnection when servicing controls. Wiring errors can cause improper and dangerous operation. Verify proper operation after servicing.

Note: The lower cover panel is removable if finish material has not been installed.

WARNING! Risk of Shock! Replace damaged wire with type 105 °C rated wire. Wire must have high temperature insulation.

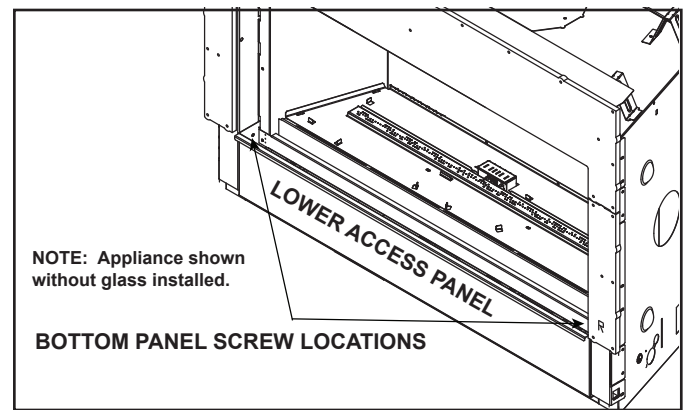

Figure 8.1 Lower Access Panel Location

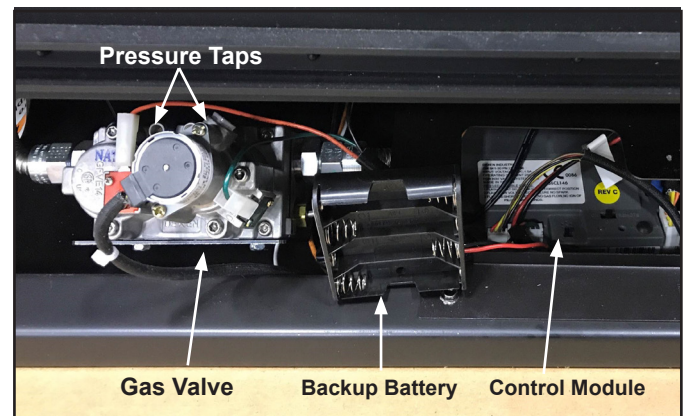

Figure 8.2 Gas Valve, Backup Battery & Control Module

B. Wiring Requirements

IntelliFire™ Plus Ignition System Wiring

- Wire the appliance junction cord to 220/240 VAC for proper operation of the appliance.

WARNING! Risk of Shock or Explosion! DO NOT wire IPI controlled appliance junction cord to a switched circuit. Incorrect wiring will override IPI safety lockout.

- Refer to Figure 8.3, IPI Wiring Diagram.
- This appliance is equipped with an IntelliFire™ Plus control valve which operates on a 6 volt/1.5 AMP system.
- Plug the 6 volt transformer plug into the appliance junction cord to supply power to the unit OR install 4 AA cell batteries (not included) into the battery pack before use.

NOTICE: Batteries should only be used as a power source in the event of an emergency power outage. Batteries should not be used as a primary long-term power source. Battery polarity must be correct when installing batteries. When using batteries as a power source, the 6-volt transformer must be unplugged from the receptacle.

Do not store batteries in the battery pack when the appliance is powered by the 6 volt transformer connected to permanent electrical service.

Accessories Requirements

- This appliance ships standard with a remote control.

Wiring for optional Hearth & Home Technologies approved accessories should be done now to avoid reconstruction. Follow instructions that come with those accessories.

The junction cord and control module can be accessed by removing the vanity panel and component heat shield. The decorative front must be removed to access these components. See Figure 8.3.

CAUTION! Risk of Overheating! Component heat shield **MUST** be installed before operating appliance. Electrical components will be damaged.

CAUTION! Risk of Overheating! DO NOT remove component heat shield. Electrical components will be damaged.

Note: For more information regarding the control module and remote control, please refer to the Owner's Manual.

Note: When using PVLP-SLP-AU power vent, see PVLP-SLP-AU instructions for additional wiring requirements.

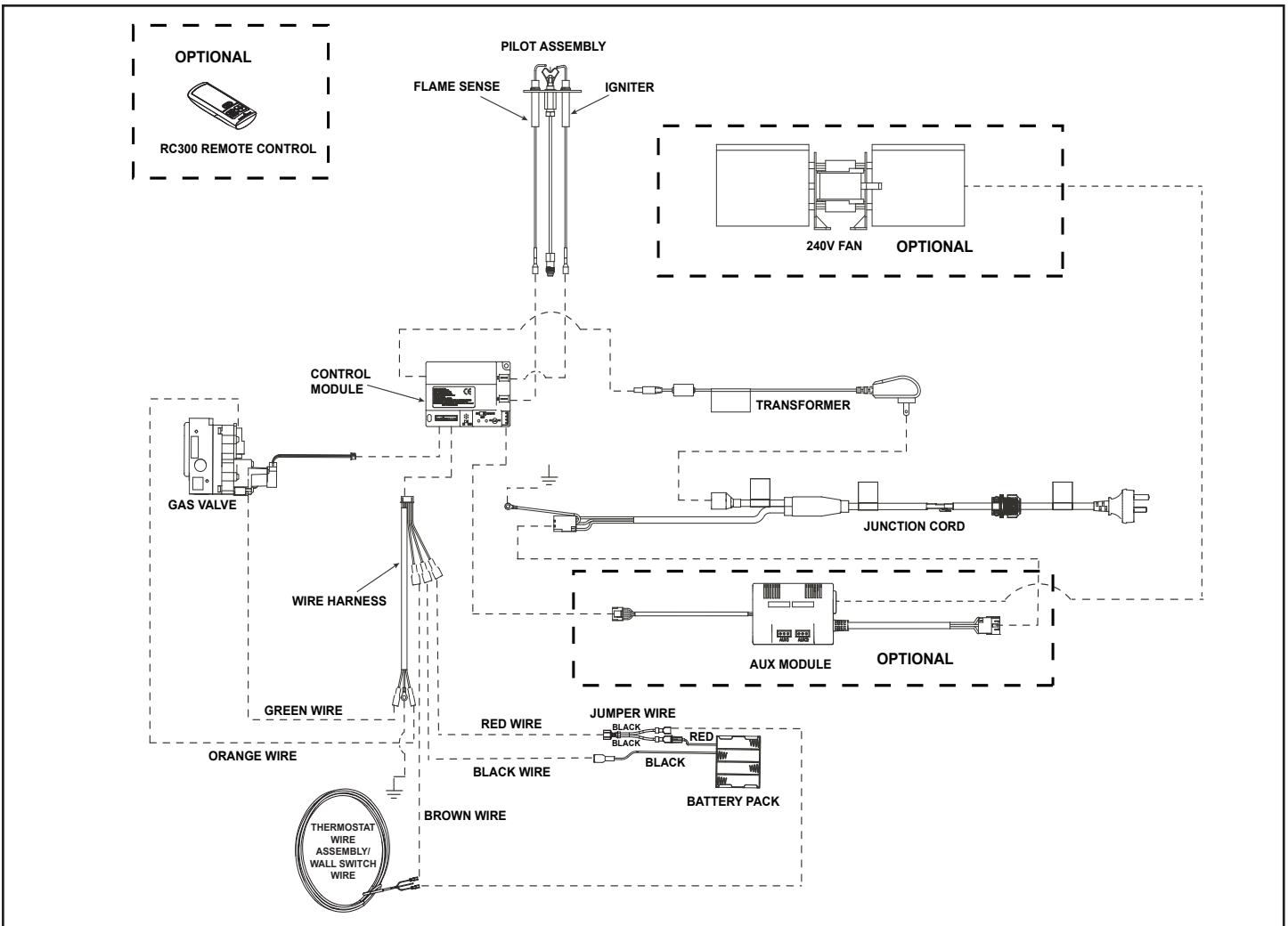

Figure 8.3 IntelliFire™ Plus Wiring Diagram

9 Gas Information

A. Fuel Conversion

- Make sure the appliance is compatible with available gas types.
- Conversions must be made by a qualified service technician using Hearth & Home Technologies specified and approved parts.

B. Gas Pressure

WARNING! Risk of Explosion! An in-line regulator *MUST* be installed if the gas pressure exceeds 3.4 kPa. Failure to install a regulator could damage valve.

Pressure requirements for B41L-AU fireplaces are shown in the table below.

Two taps are provided on the right hand side of the gas control for a test gauge connection to measure the inlet and outlet pressures.

The fireplace and its individual shut-off valve must be disconnected from the gas supply piping system during any pressure testing of the system at test pressures in excess of 6 kPa.

If the fireplace must be isolated from the gas supply piping system by closing an individual shut-off valve, it must be of the handle-less type.

- Optimum appliance performance requires proper input pressures.
- Pressure requirements are:

Gas Pressure	Natural Gas	Propane
Minimum inlet pressure	1.13 kPa	2.75 kPa
Maximum inlet pressure	3.40 kPa	3.40 kPa
Manifold pressure	.87 kPa	2.40 kPa

WARNING! Risk of Fire or Explosion! High pressure will damage valve. Low pressure could cause explosion.

- Verify inlet pressures. Verify minimum pressures when other household gas appliances are operating.
- Install regulator upstream of valve if line pressure is greater than 1/2 psig.

⚠ WARNING



Fire Risk.
Explosion Hazard.
High pressure will damage valve.

- Disconnect gas supply piping **BEFORE** pressure testing gas line at test pressures above 1/2 psig.
- Close the manual shutoff valve **BEFORE** pressure testing gas line at test pressures equal to or less than 1/2 psig.

C. Gas Service Access

Access Through the Control Cavity

The lower access cover panel is removable if finishing material has not been previously installed. See Section 8.A for removal instructions.

Access Through the Valve Assembly

1. Locate and remove the two screws that secure the base pan to the appliance. See Figure 9.1. Remove base pan. Retain screws.

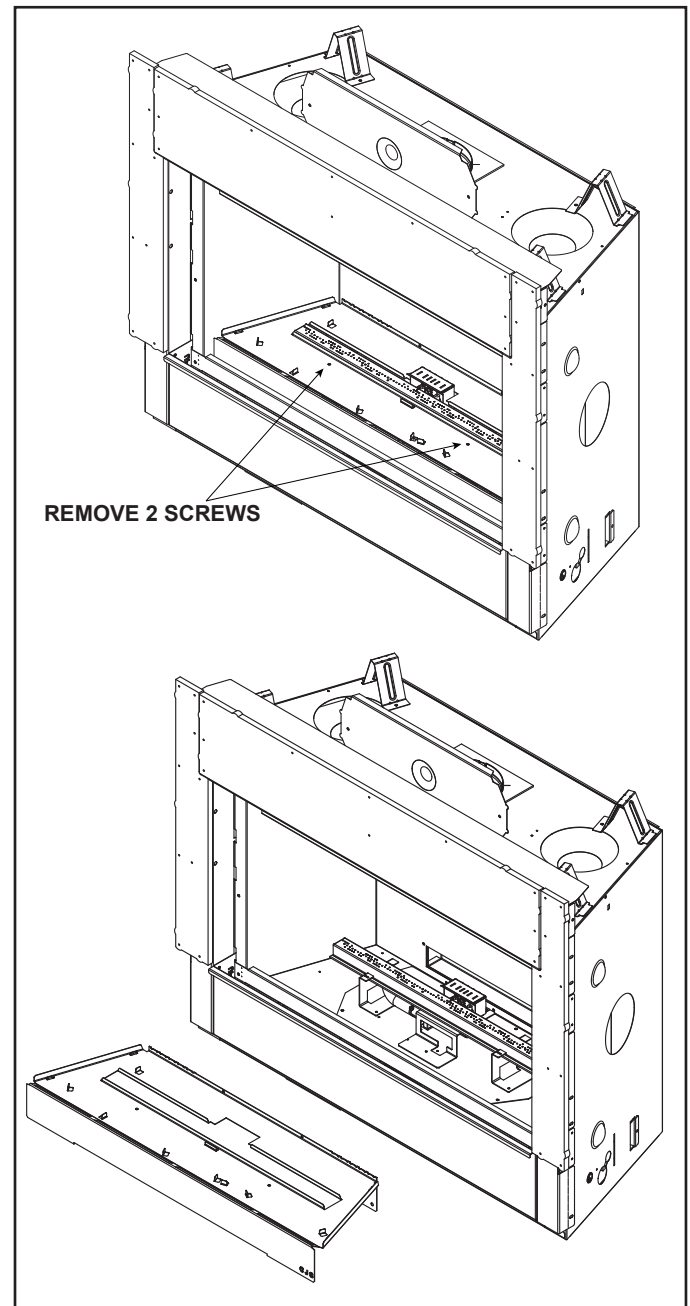

Figure 9.1 Base Pan Removal

2. Remove the two screws that secure the pilot shield to the burner bracket and remove the two screws that secure the pilot assembly to the burner bracket. Remove the one screw that secures the burner bracket to the valve plate. See Figure 9.2. Gently push the pilot assembly backwards to allow for the burner to be removed.
3. Slide burner assembly to the left to disengage the burner tube from the orifice. Remove the burner from the appliance.
4. Remove the nine screws around the perimeter of the valve plate that secure valve plate to the appliance. See Figure 9.3.
5. Lift up on the plate assembly. Disconnect the ball valve assembly from the gas valve by loosening the compression fitting located on the left side of the gas valve.
6. Upon completion of service, reverse steps 1-6. If the valve plate gasket is damaged, replace the gasket prior to reinstallation of valve plate assembly.

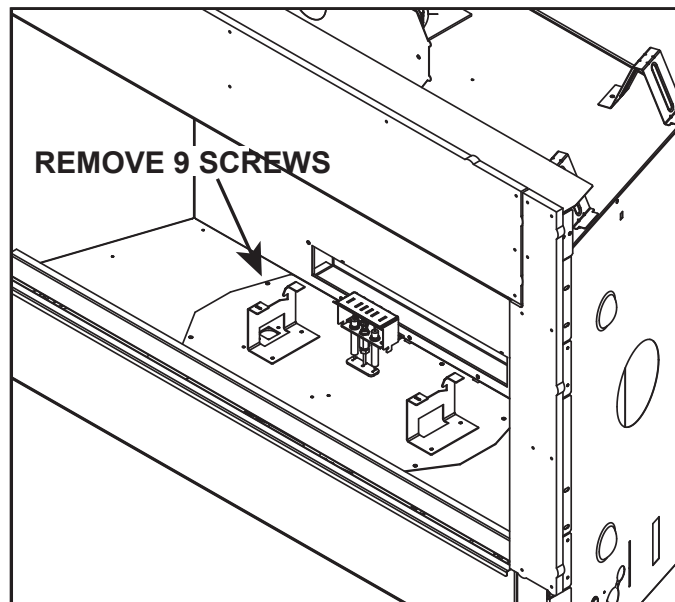

Figure 9.3 Remove Valve Plate

Valve Pressure Taps

The pressure taps are accessible by removing the lower panel prior to finishing material installation. There is limited access to the pressure taps after finishing material installation. Remove glass assembly and utilize an appropriate sized screwdriver. See Figure 8.2.

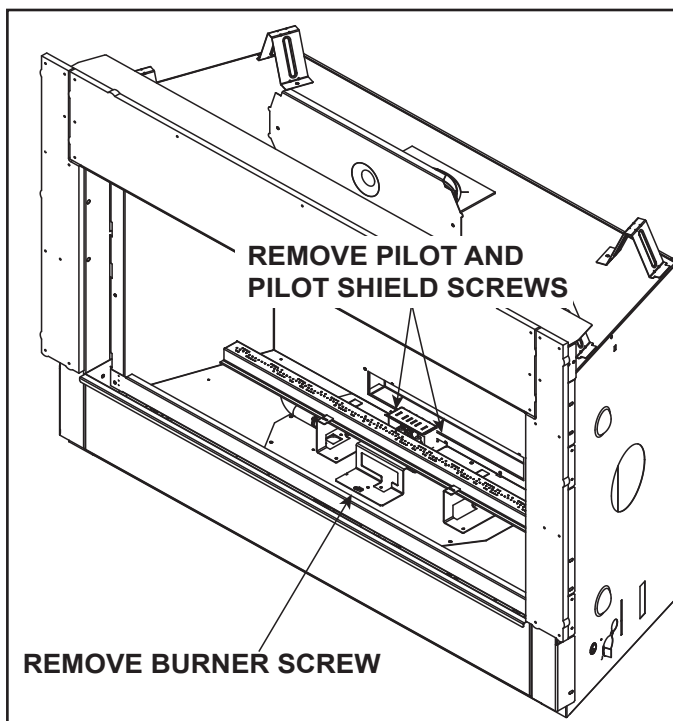

Figure 9.2 Burner Removal

D. Gas Connection

Note: Have the gas supply line installed in accordance with local building codes by a qualified installer approved and/or licensed as required by the locality.

Note: Before the first firing of the appliance, the gas supply line should be purged of any trapped air.

Note: Consult local building regulations to properly size the gas supply line leading to the (Rp 1/2 in.) hook-up at the unit.

Incoming gas line should be piped into the valve compartment and connected to the ISO 7-Rp 1/2 (BSP Rp 1/2) threaded gas inlet connection on the manual shutoff valve.

IMPORTANT NOTICE: (Items 1, 2 and 3 applies to ALL Hearth & Home Technologies gas appliances)

1. **1/2 in. GAS LINE:** Run through cavity 70 mm above finished hearth level, **NOT RIGID, NOT CLIPPED**, with minimum 500 mm into cavity and 120 mm back from plaster face.
2. **PVC (COMPOSITE) GASLINE** must terminate minimum 500 mm short of gas heater. Copper pipe **MUST** be the final connection to the gas heater.
3. **ISOLATING SWITCH:** Location within 1 metre of fireplace, subject to mantelpiece etc. Check to ensure it remains clear of any mantelpiece installation.

Leak test all gas line points and the gas control valve prior to and after starting the gas appliance.

E. High Altitude Installations

NOTICE: If the heating value of the gas has been reduced, these rules do not apply. Check with your local gas utility or authorities having jurisdiction.

When installing above 2000 ft. (610 m) elevation:

Reduce input rate 4% for each 1000 ft. (305 m) above 2000 ft. (610 m).

F. Air Shutter Setting

The Natural Gas Shutter setting is pre-set for the minimum (vertical and horizontal) one elbow horizontally terminating application. For appliances intended to operate with Propane Gas, a conversion kit is required and the air shutter is to be adjusted during the conversion and shutter verification process.

Air shutter settings should be adjusted by a qualified service technician at the time of installation. Adjust air shutter for longer vertical runs. See Figure 9.4.

- Loosen the 1/4 in. (6 mm) screw.
- Twist the air shutter to adjust.
- Tighten the 1/4 in. (6 mm) screw.

Shutter Setting Verification / Flame Appearance

- After 15 minutes, the flames will be a yellow/blue mix. The front flames may be blue at this time.
- After 30 minutes, the flames should be yellow with some blue flames near the burner ports.
- After 1 hour, the flame will be at its maximum maturity.

NOTICE: If flames lack the desired yellow appearance, adjust the shutter to a more “closed” position. If flames are dark orange with smoky tips, adjust the shutter to a more “open” position.

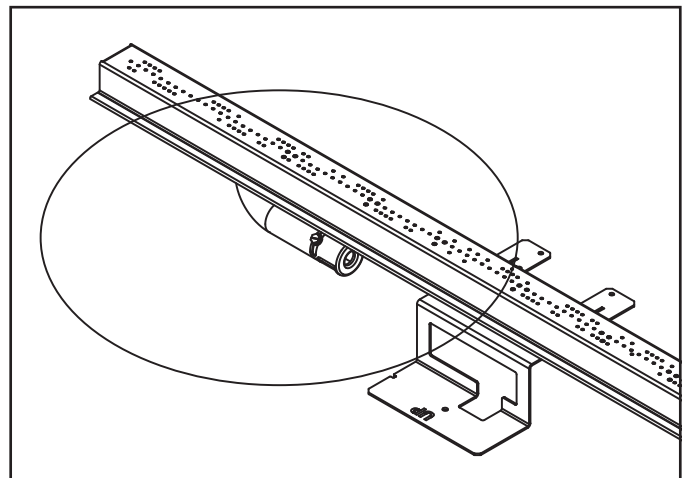

Figure 9.4 Air Shutter Location

Air Shutter Settings

	Glass Media Option or Driftwood Option	Traditional Log Option
B41L-AU (NG)	1/8 in. (3 mm)	3/16 in. (5 mm)
B41L-AU (LP)	1/4 in. (6 mm)	5/16 in. (8 mm)

10 Finishing

A. Facing Material

⚠ WARNING

Risk of Fire!

DO NOT apply combustible materials beyond the minimum clearances. Comply with all minimum clearances to combustibles as specified in this manual. Materials overlapping into non-combustible zones could ignite and will interfere with air flow through decorative barrier fronts.

- Metal front of appliance may be covered with non-combustible materials only.
- Facing and/or finishing materials must not interfere with air flow through decorative barrier fronts, removal of decorative barrier fronts or access for service.
- Facing and/or finishing materials must never overhang into the glass opening.
- Observe all clearances when applying combustible materials.
- Seal gaps between the finished wall and appliance top and sides using a 300 °F minimum sealant. Refer to Figure 10.1 and Figure 10.2.

NOTICE: Surface temperatures around the appliance will become warm while the appliance is in operation. Ensure finishing materials used for all surfaces (floor, walls, mantels, etc.) will withstand temperatures up to 190°F.

WARNING! Risk of Fire! Comply with all minimum clearances to combustibles as specified. Framing closer than the minimums listed must be constructed entirely of non-combustible materials (i.e., steel studs, concrete board, etc.)

The appliance is designed to accept 10 mm wall sheathing materials such as drywall, plywood, wood composites, or non-combustible materials. The type of material used depends whether the installation is an Inside or Overlap Fit Method. Refer to Section 10.D regarding installation details associated with the Inside and Overlap Fit methods.

The factory-supplied non-combustible board must be used in all installations. It must be directly attached to structural framing adjacent to the appliance. Screw fasteners should be installed in the pilot holes provided in the outer perimeter of the non-combustible board. See Figure 10.1 and Figure 10.2.

The factory-supplied board is designed such that its edges will be at the approximate center of the adjacent framing, assuming it is 1-1/2 in. nominal thickness. This will allow the wallboard joints to occur on the center of the framing where the panels can be fastened properly. If the framing thickness is less than 1-1/2 in. nominal, such as with formed steel systems, then it may be necessary to adjust the adjacent framing dimensions so that the non-combustible board and wallboard joints are centered on the framing.

Finishing Instructions

It is important to follow the framing and finishing instructions to ensure proper placement of fireplace into the surrounding framing/finishing materials.

Wall sheathing materials 10 mm thick are specified in this installation manual to properly align with the factory-installed non-combustible material.

WARNING! Risk of Fire! DO NOT remove the factory-installed non-combustible board or cover it with combustible material, such as:

- Drywall (gypsum board)
- Plywood
- Materials that do not meet the ASTM E 136 Non-combustibility standard (below).

Removal of factory-installed, non-combustible board and/or use of materials not meeting the ASTM E 136 standard may cause fire.

- Facing and/or finishing materials must not interfere with air flow through decorative barrier fronts.
- Facing and/or finishing materials must never overhang into the glass opening.
- Observe all clearances when applying combustible materials.

WARNING! Risk of Fire! DO NOT apply combustible materials beyond the minimum clearances. Comply with all minimum clearances to combustibles as specified in this manual. Overlapping materials could ignite and will interfere with proper operation of decorative barrier fronts.

WARNING! Risk of Fire! DO NOT install drywall or other combustible materials over the factory-installed non-combustible board. Overlapping materials could ignite.

Decorative facing material thickness is measured from the face of the factory-installed non-combustible board. See Section 10.D for Overlap Fit and Inside Fit requirements.

Non-Combustible Materials Specification

Material which will not ignite and burn. Such materials are those consisting entirely of steel, iron, brick, tile, concrete, slate, glass or plasters, or any combination thereof.

Materials that are reported as passing **ASTM E 136, Standard Test Method for Behavior of Materials in a Vertical Tube Furnace at 750 °C.**

B. Non-Combustible Board and Drywall Installation

Introduction

If the desired finished fireplace installation does not utilize non-combustible finishing materials (such as tile, marble, stone, etc.), special attention must be paid to the installation of drywall/gypsum wallboard to minimize potential development of cracking and paint discoloration. Hearth and Home Technologies has tested the following methods and materials and therefore recommends the following steps for the best drywall performance.

Attaching Non-Combustible Board to Framing

1. To ensure the lower cover panel has been correctly installed, verify that two screws (total) have been installed in the lower left and right sides of the fireplace opening. See Figure 8.1. These screws, when installed, will ensure the lower panel is correctly installed. If the lower cover panel is not correctly installed, the decorative front may not fit into the fireplace opening correctly. Refer to section 6.D for more information regarding the included non-combustible board.
2. The appliance ships with the required non-combustible board. The large top piece of non-combustible board is pre-installed at the factory. The narrow left and right non-combustible pieces are shipped within the appliance. Install the non-combustible side pieces with the screws provided in the manual bag assembly. There are pilot holes located on the left and right side columns. Care should be taken not to tighten these screws into the non-combustible board excessively. Set screws flush to the face of the non-combustible board. See Figure 10.2 and Section 6.D.
3. The outer perimeter of the factory-installed non-combustible board has pre-drilled pilot holes. See Figure 10.1. Secure the non-combustible board to adjacent framing with drywall screws that are a minimum of 1-1/4 inch in length. Care should be taken not to tighten these screws into the non-combustible board excessively. Set screws flush to the face of the non-combustible board. See Figure 10.2 and Section 6.D.
4. When installing drywall around the appliance, install a rectangular hole for the fireplace/non-combustible board in a single sheet of drywall. This will minimize the joints that require finishing adjacent to the fireplace opening. Ensure that the 1/8 inch gap is maintained between the factory installed non-combustible board and the surrounding drywall. See Figure 10.1. Secure the drywall to the framing with screws a minimum of one inch in length every six inches across the top of the fireplace and every ten inches on the sides of the fireplace.
5. To ensure good adhesion of drywall compounds and tape, thoroughly clean the non-combustible board and surrounding drywall to remove dust. The non-combustible board may be primed with a high-quality PVA primer.

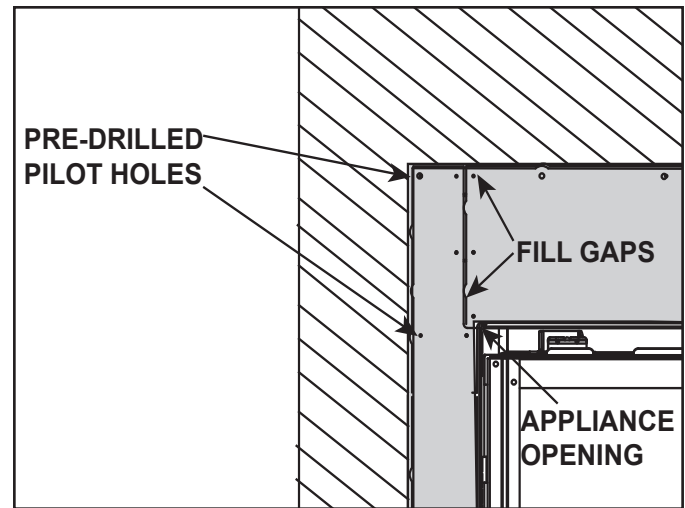

Figure 10.1 Install Non-Combustible Board

Filling and Finishing Seams

1. **Step 1:** Fill all gaps and joints between the non-combustible board pieces and the drywall with a general purpose chemically setting joint compound such as Durabond® 45 Joint Compound manufactured by USG (Sheetrock® brand), recommended by Hearth & Home Technologies. Use a drywall knife to firmly press the joint compound into all gaps. See Figure 10.1. Allow these joints to dry.
2. **Step 2:** All joints are to be taped with fiberglass mesh tape 1 7/8" minimum width, and embedded with Setting-Type joint compound, such as with Durabond® Joint Compound manufactured by USG (Sheetrock® brand), or equivalent. Allow these joints to dry.
3. **Step 3:** Depending on the technique used in steps 1 and 2, two to three finishing coats are required to provide a smooth and durable finish. Hearth and Home Technologies recommends a lightweight or all-purpose compound. Allow each coat to properly cure. Allow the finishing coat(s) to cure for 24 hours before operating appliance.

Painting

If desired finishing includes a painted wall, a high-quality 100% acrylic latex paint with a high-quality latex primer base coat are recommended around the appliance to limit discoloration. Oil-based or standard acrylic paints may be more prone to discoloration due to heat exposure.

Drywall Joint-Crack Prevention and Repair

Drywall joints around the fireplace will be affected by exposure to elevated temperatures, along with other environmental, structural factors due to new construction, and methods used to install and finish the drywall. If a crack does emerge adjacent to the fireplace, it can be permanently repaired by filling it with a paintable latex caulk, followed by repainting.

Some movement of the screws used to secure the non-combustible board to the appliance/surround framing is expected. If a blemish begins to show over a screw head, sand the surface to remove the blemish and repaint.

WARNING! Risk of Fire! Maintain specified air space clearances to combustibles. Inadequate air space could cause overheating and fire.

WARNING! Risk of Fire! Maintain specified air space clearances to combustibles. Failure to comply with these instructions may cause a fire or cause the appliance to overheat.

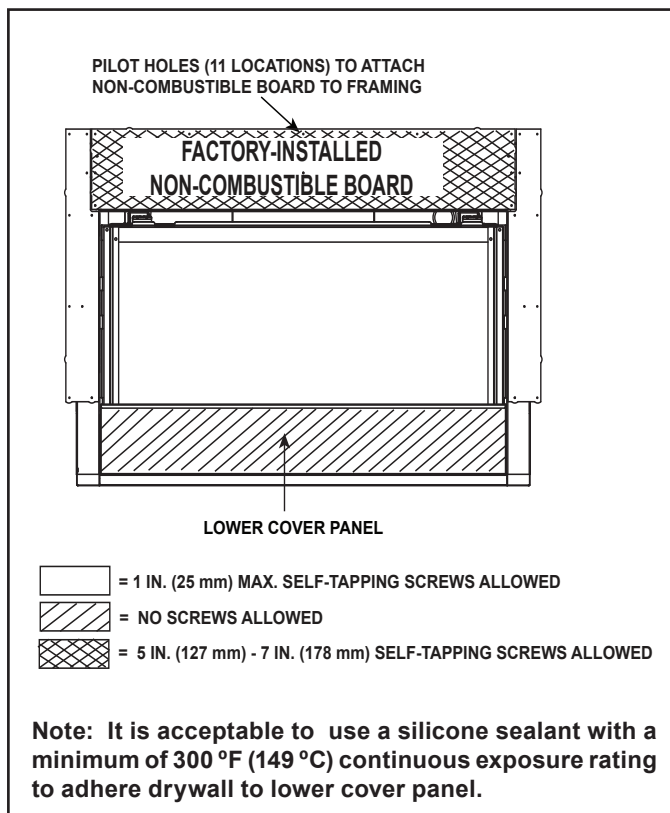

Figure 10.2 Finishing Details

CAUTION! Risk of Glass Damage and Cuts! DO NOT drill or install any type of screw or fastener into the lower cover panel. Sharp screw or fastener tips may penetrate and break the glass or cause cuts.

The final fireplace installation can be accomplished by either the Overlap Fit or Inside Fit method. Reference Section 10.D regarding installation details associated with the Inside Fit and Overlap Fit methods.

It is acceptable to pre-drill holes and use self-tapped screws in the factory-installed non-combustible board to attach non-combustible backer board for tile, marble, etc. Refer to Figure 10.2 for acceptable screw location and screw length requirements.

Do not drill or install screws which may penetrate the lower cover panel as this will restrict required access to the glass, battery-back-up, and control module. See Figure 10.2.

Note: If the desired look is painted drywall, it is recommended that no additional screws are installed into the factory-provided non-combustible board. Only install the screws provided into the pilot holes located in the factory-provided non-combustible board.

NOTICE: The location of the Passive Heat discharge opening could allow for venting and other construction materials to be visible. It is acceptable to paint the vent pipe and other construction materials using a high temperature paint with a minimum of 300 °F (149 °C) continuous exposure rating. Hearth & Home Technologies recommends using black touch up paint (part number TUP-GBK-12) available from your Hearth & Home Technologies dealer.

C. Mantel and Wall Projections

WARNING! Risk of Fire! Comply with all minimum clearances as specified. Framing closer than the minimums listed must be constructed entirely of non-combustible materials (i.e., steel studs, concrete board, etc.).

Note: Measurement is taken from top of the opening, NOT the top of the fireplace.

Combustible Mantels

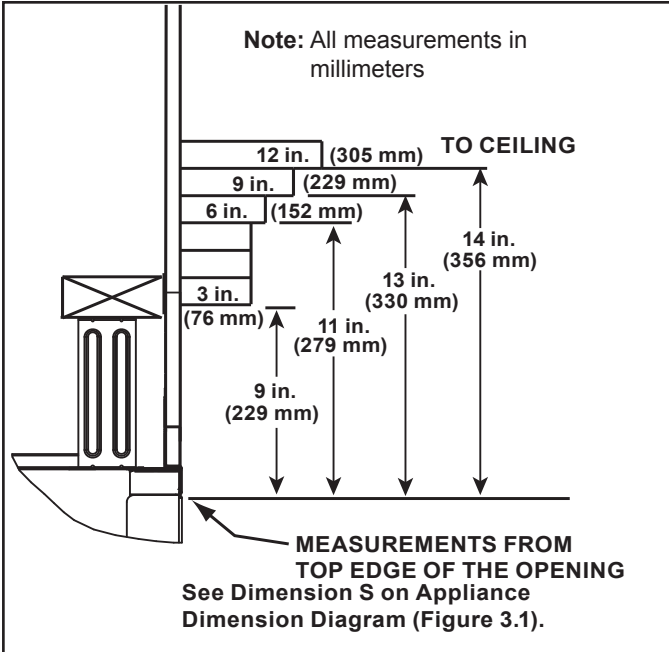

Figure 10.3 Minimum Vertical and Maximum Horizontal Dimensions of Combustibles

Combustible Mantels - Passive Heat Kit Installed

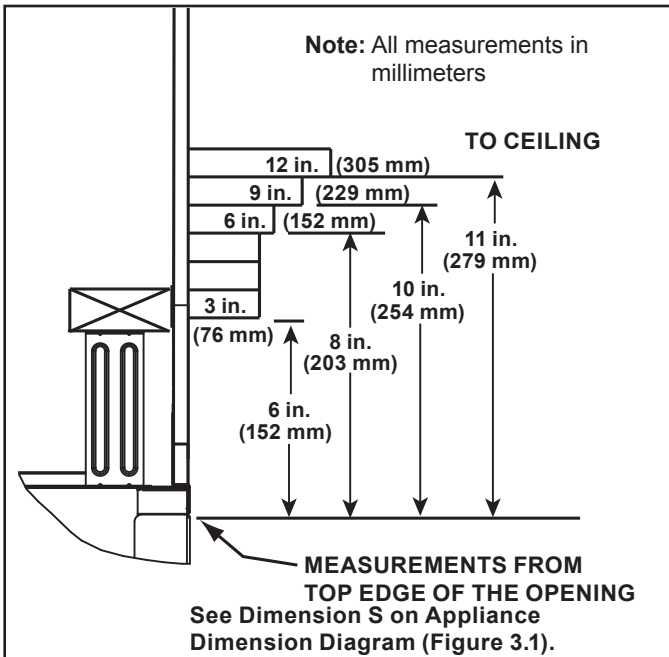

Figure 10.4 Minimum Vertical and Maximum Horizontal Dimensions of Combustibles

Non-Combustible Mantels

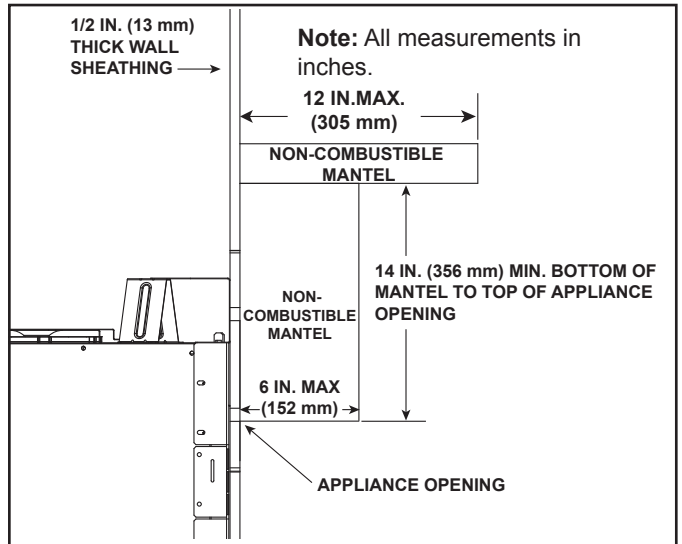

Figure 10.5 Minimum Vertical and Maximum Horizontal Dimensions of Non-Combustibles

Combustible and Non-Combustible Mantel Legs or Wall Projections

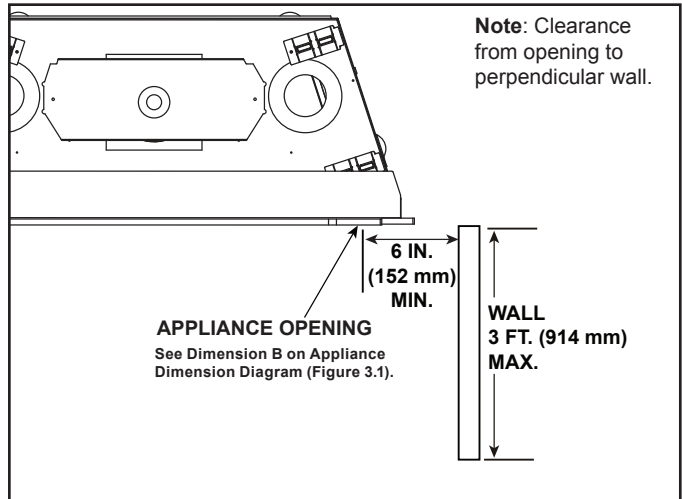

Figure 10.6 Combustible and Non-Combustible Mantel Leg or Wall Projections (Acceptable on both sides of opening)

Combustible and Non-Combustible Mantel Legs or Wall Projections

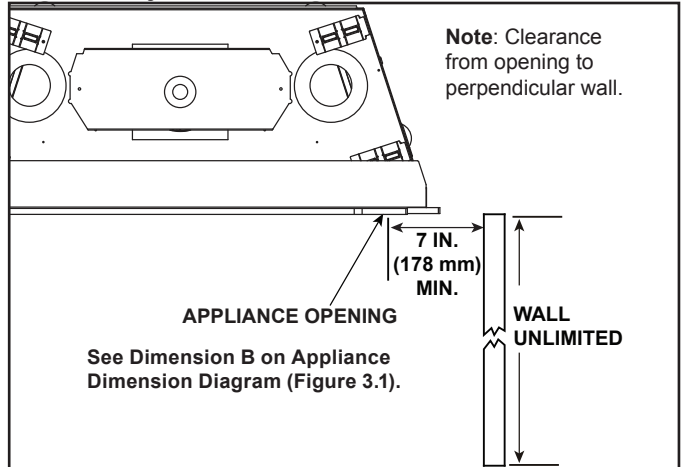
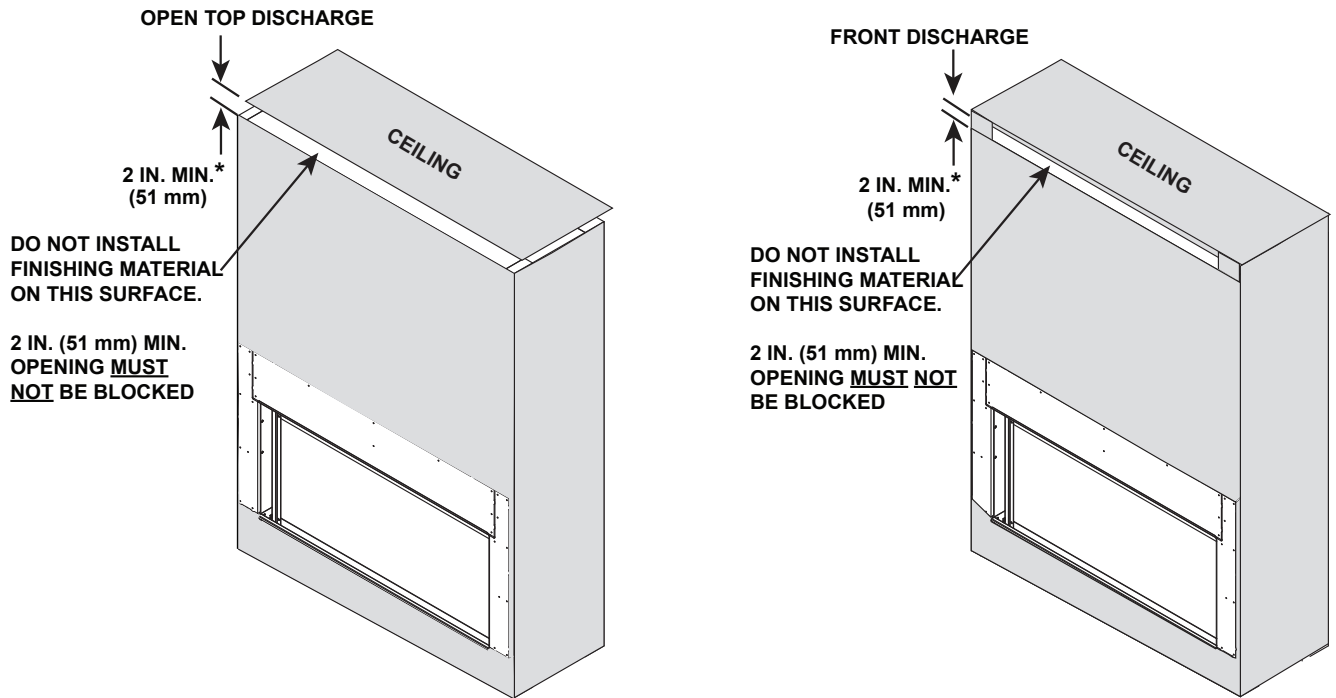

Figure 10.7 Combustible and Non-Combustible Mantel Leg or Wall Projections (Acceptable on both sides of opening)

Finishing Material Installed with Passive Heat Optional Heat Management System



* = Mesh screen required for front discharge or open top discharge passive heat installations with discharge opening of 3 in. (76 mm) or greater.

SIDE DISCHARGE (DISCHARGE SLOTS ON BOTH SIDES OF APPLIANCE)

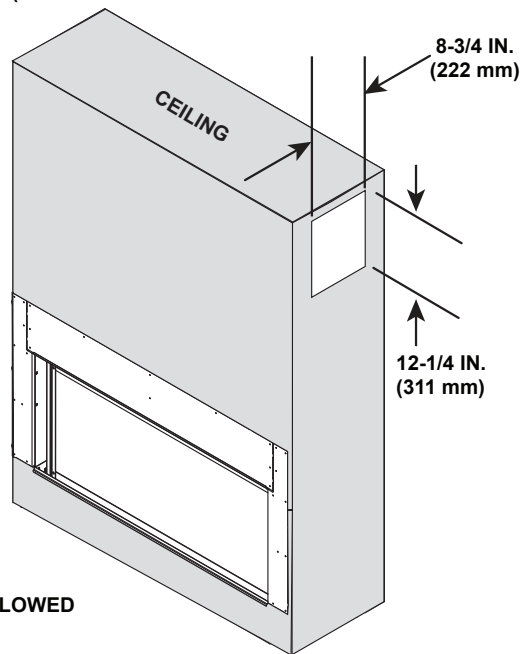

 = COMBUSTIBLE MATERIAL ALLOWED

Figure 10.8 Finishing Material installed with Passive Heat Optional Heat Management System

D. Decorative Barrier Front Finishing

WARNING! Risk of Fire! A decorative front is required for this model. **DO NOT** operate this appliance without a decorative front in place.

THE GUARD IS FITTED TO THIS APPLIANCE TO REDUCE THE RISK OF FIRE OR INJURY FROM BURNS AND NO PART OF IT SHOULD PERMANENTLY BE REMOVED. FOR PROTECTION OF YOUNG CHILDREN OR THE INFIRM. A SECONDARY GUARD IS REQUIRED.

Only decorative barrier fronts certified for use with this appliance model may be used. Contact your dealer for a list of decorative barrier fronts that may be used.

Overlap Fit

(0 - 1 in. max. (0 - 25 mm max.) Thick Finishing Material)

**Non-Combustible Finish Materials
0 - 1 in. (0 - 25 mm) Thick
Overlap Fit Method**

The CFTF is designed to overlap finish materials 0 in. to 1 in (0 - 25 mm) thick. See Figure 10.10.

NOTICE: This one inch maximum not only includes the decorative finish materials (marble, tile, slate, etc) but also the mortar or adhesive used to attach the decorative finish material.

The non-combustible finish material can be installed up to the fireplace opening.

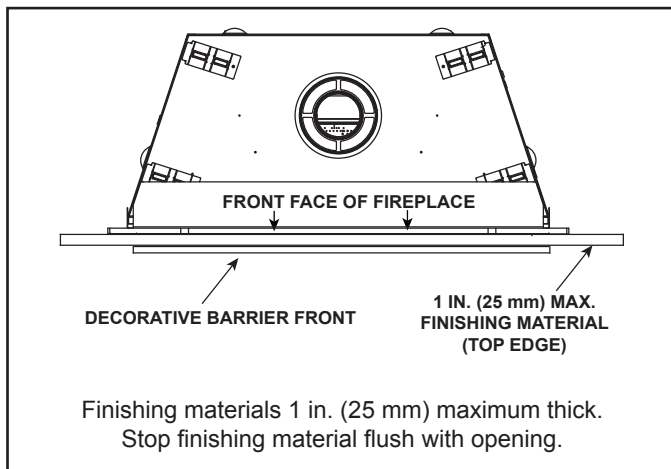

Figure 10.9 Overlap Fit Decorative Front (CFTF Decorative Front)

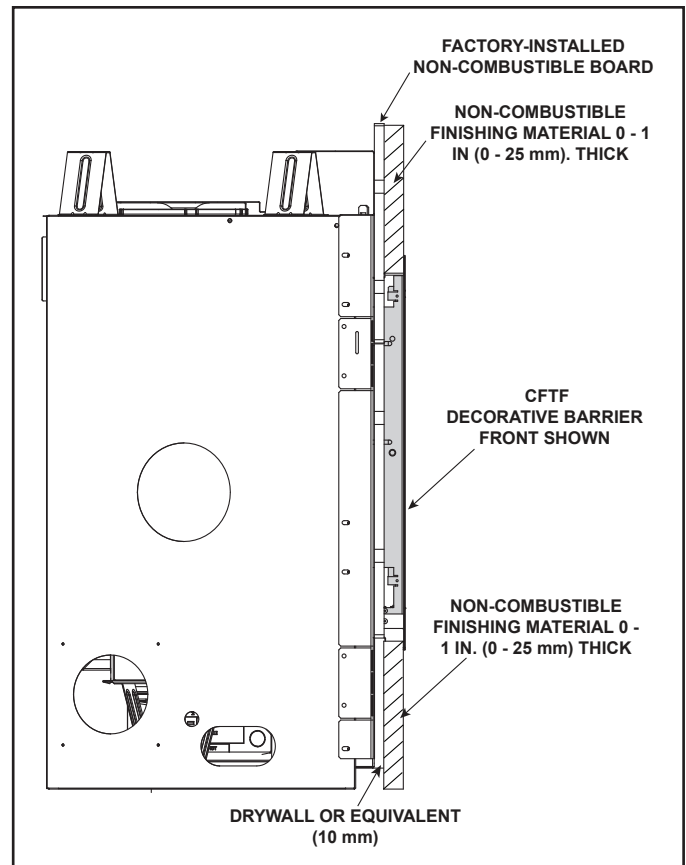

Figure 10.10 Overlap Fit Method (CFTF Decorative Barrier Front)

Inside Fit - CFTF Front (1 Inch to 6 Inch Thick Finishing Material)

The CFTF is approved for inside fit applications (finish material over 1 in. (25 mm) thick). The CFTF decorative barrier front can be installed with or without the outer decorative barrier front trim (included with the decorative barrier front). See Figure 10.11.

If the desired look is to include the outer decorative barrier front trim, finishing materials up to 1-3/16 in. (30 mm) around the fireplace opening. See Figure 10.12. For this installation, the inner decorative barrier front hangs on four tabs located on outer decorative barrier front trim. The auxiliary hanging brackets are not used and may be discarded. See Figure 10.13.

If the desired look is to exclude the outer decorative barrier front trim, finishing material can be installed up to the fireplace opening. See Figure 10.14. For this installation, the inner decorative barrier front hangs on four tabs located on the auxiliary hanging brackets. The outer decorative front trim is not used and may be discarded. See Figure 10.15.

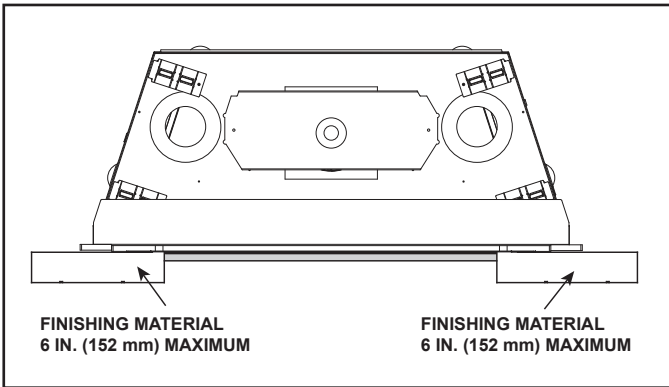

Figure 10.11 Maximum Non-Combustible Finish Material Thickness - CFTF Decorative Barrier Front

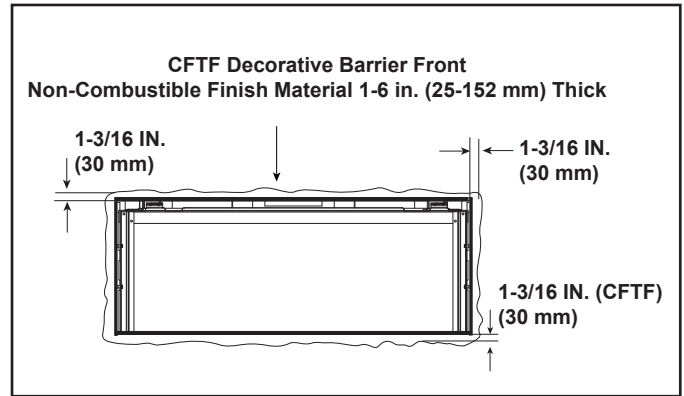

Figure 10.12 Clearances to Appliance Opening With Outer Decorative Barrier Front Trim

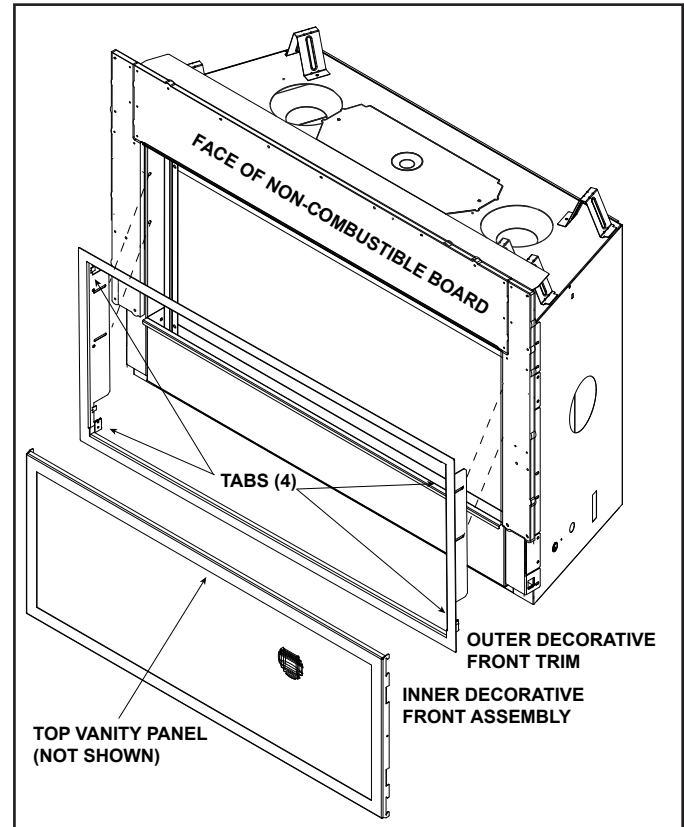

Figure 10.13 CFTF Front Installation With Outer Decorative Barrier Front Trim

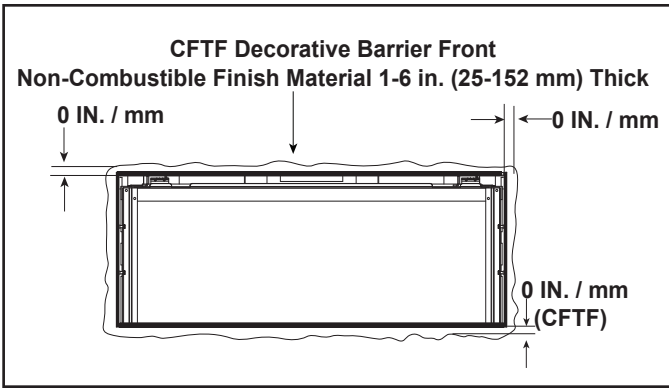

Figure 10.14 Clearances to Appliance Opening Without Outer Decorative Barrier Front Trim

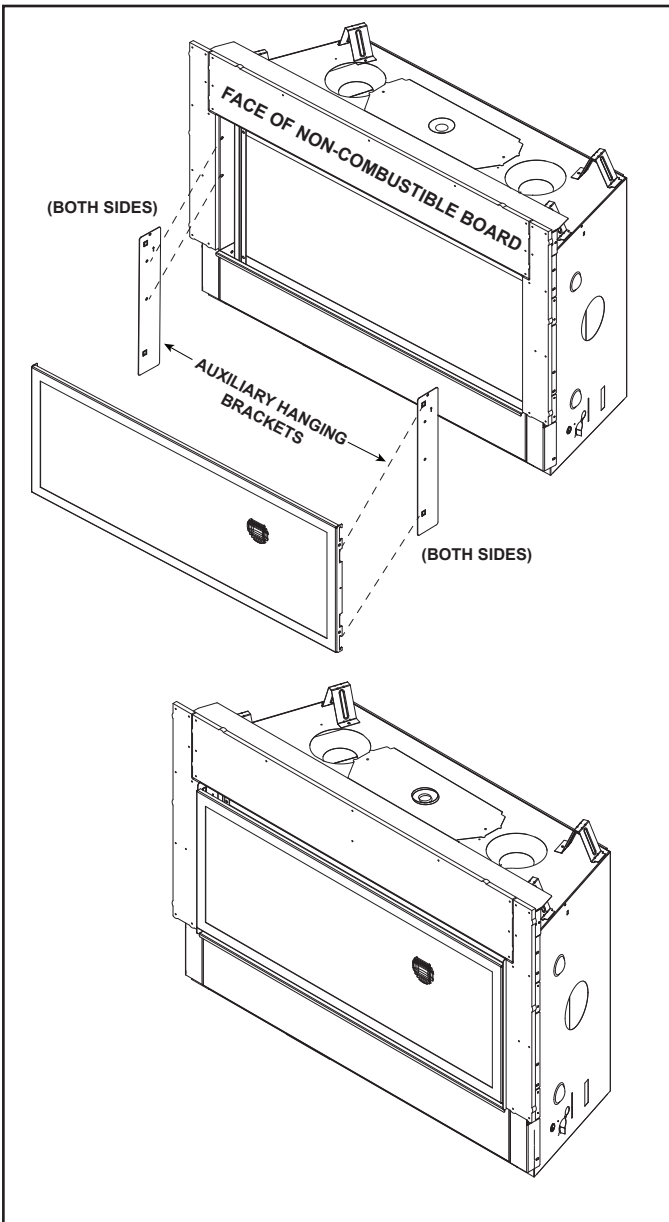
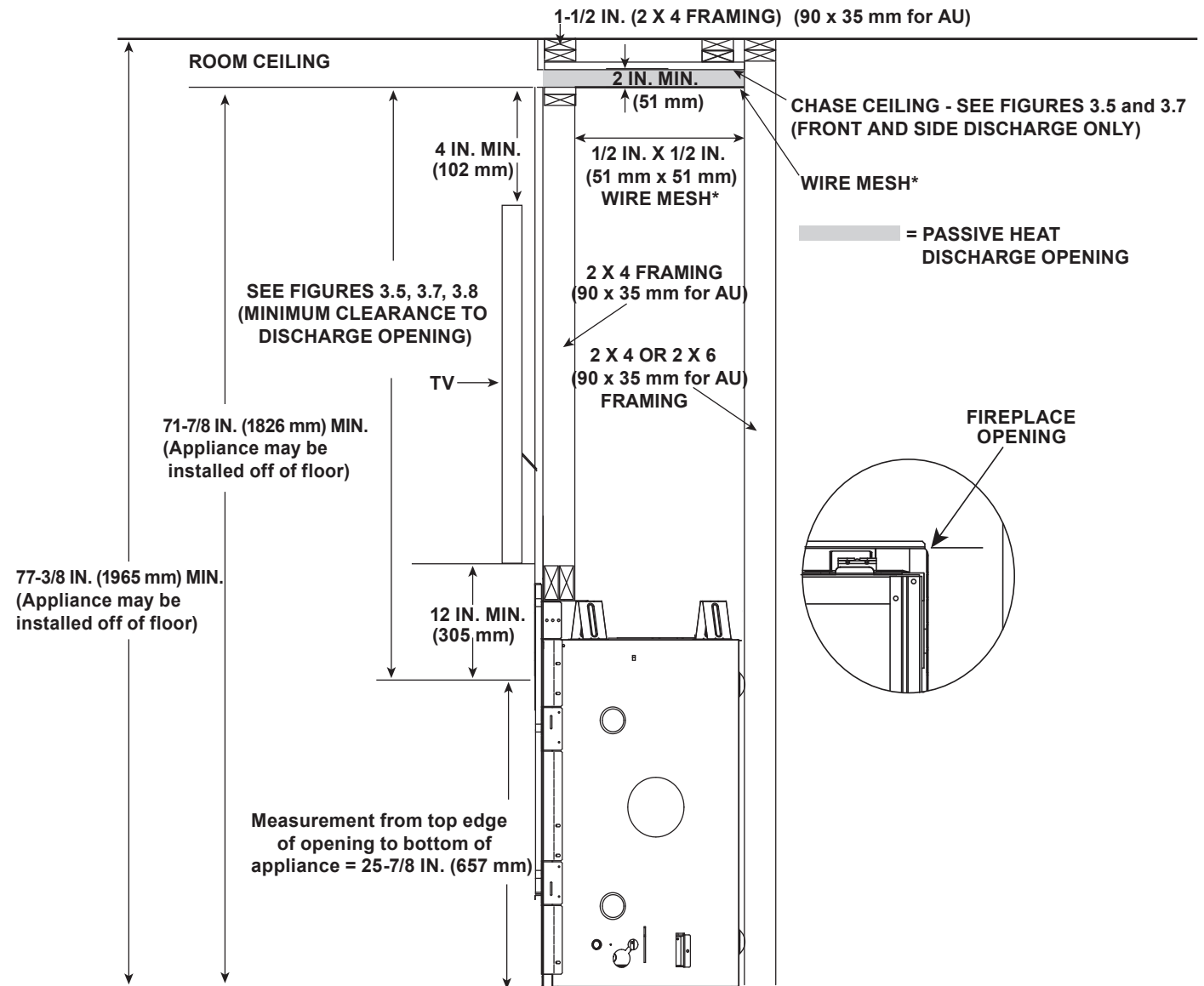

Figure 10.15 CFTF Front Without Outer Decorative Barrier Front Trim

Good Faith TV Guidelines

Good Faith Guidelines for TV Installations Above a Fireplace with Passive Heat Option

WARNING! Risk of Fire! Wire mesh required on bottom of discharge opening when discharge opening is greater than 3 in. (76 mm). Secure wire mesh to top of framing.



* Wire mesh required for front discharge or open top discharge passive heat installations with discharge opening of 3 in. (76 mm) or greater.

NOTE: The TV installation requirements are the same regardless of whether the Passive Heat kit is installed with a top discharge, side discharge or open top discharge.

→ Figure 10.16 Good Faith Guidelines for TV Installations Above a Fireplace with Passive Heat Option

11 Appliance Setup

A. Remove the Shipping Materials

Remove shipping materials from inside or underneath the firebox.

- The splatter guard is a piece of corrugated material used to protect the appliance during the installation process before finishing work on the whole hearth is complete. Splatter guards may be factory installed or accompany the decorative barrier front of the appliance, depending on the fireplace model. Splatter guards must be removed before appliance is fired.
- The left and right side non-combustible boards are packaged within the splatter guard. Remove them by carefully disengaging the tabs from the slots on the lower portion of the splatter guard. Install as instructed in Section 6.

WARNING! Risk of Fire! Close the ball valve before installing the splatter guard to prevent accidental lighting. Remove the splatter guard before lighting the appliance.

B. Clean the Appliance

Clean/vacuum any sawdust that may have accumulated inside the firebox or underneath in the control cavity.

C. Install the Glass Refractory (Optional)

An optional glass refractory kit is available for use with the B41L-AU model. Install the glass refractory per instructions included with the kit.

D. Install Log Set or Other Optional Media - Driftwood Logs - Stones

Optional log set and other media options are available for use with the B41L-AU model. Install the log set per instructions included with the kit. The traditional log set is standard with the appliance.

NOTICE: When installing stones, driftwood logs and glass media into the B41L-AU, burner must be replaced with part number 2617-007. See installation manual for burner replacement instructions.

Traditional Log Install Instructions

NOTICE: To simplify the installation process, use Figure 11.1 to positively identify each individual log before beginning installation.



Figure 11.1 LOGS-COSMO36

1. Bend eight log tabs "up" from basepan to 90 degrees.

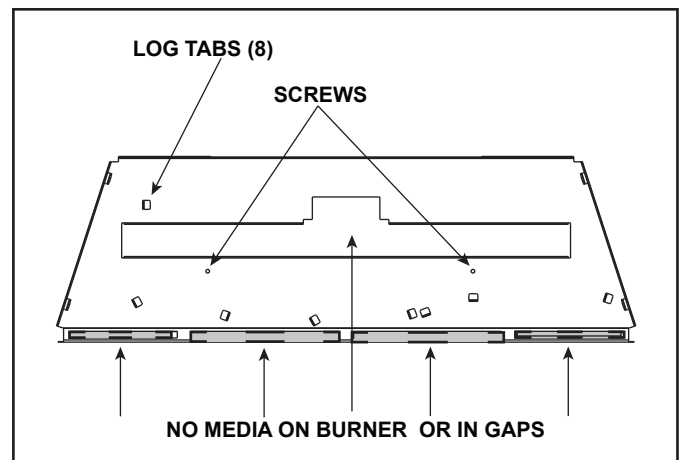

Figure 11.2 Empty Base Pan

2. Install Log #7 by placing the left side of the log touching the pilot shield and pull log forward until it contacts the sheet metal flange behind the burner. See Figure 11.3.



Figure 11.3 Place Log #7

3. Install Log #1 by locating the back left tab behind the burner. Place the log so that the left end is contacting the tab and pulled forward until it contacts the sheet metal flange behind the burner. The right end of the log rests on top of the pilot shield. See Figure 11.4.
4. Place mineral wool on the burner. Mineral wool can be placed the entire length of the burner, but it must only be placed between the front row of ports and the space in front of the burner. The mineral wool should not cover any ports or fall so that it covers the gap on either side of the burner. Refer to Figure 11.4.



Figure 11.4 Place Log #1

5. Install Log #3 by resting it on top of Log #1. Log #3 will cross the burner. The tab near the front of the basepan will rest in the notch in the front tip of the log. See Figure 11.5.

Note: When Log #3 is correctly positioned on Log #1, the left side of the log will be just outside the left end of the burner. See Figure 11.6.



Figure 11.5 Place Log #3

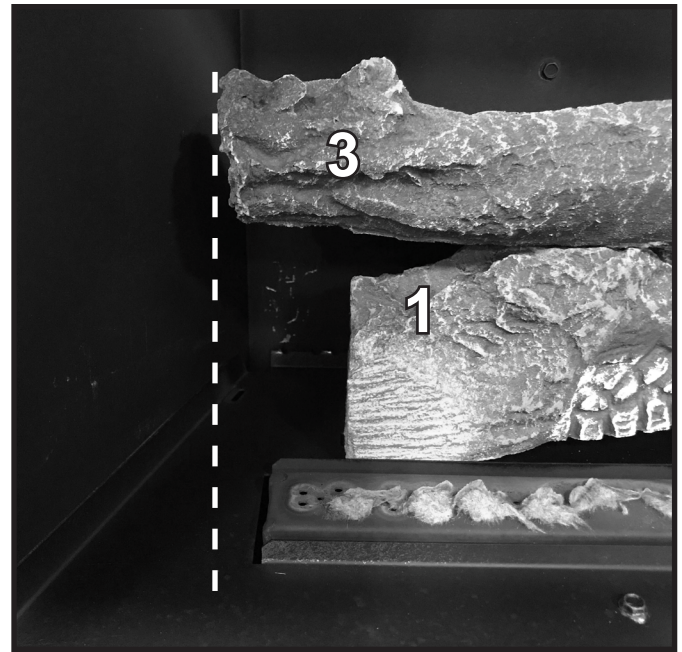

Figure 11.6 Place Log #3

6. Install Log #6 by placing the right end of the log against the right log tab. The left end of the log will contact the back side of the left tab. The back end of Log #6 will sit on top of Log #7. See Figure 11.7.

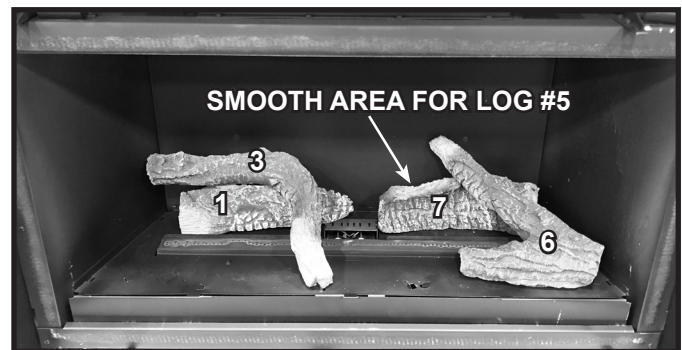

Figure 11.7 Place Log #6

7. Install Log #5 by placing the forked end down as shown in Figure 11.8. One side of the fork will rest on Log #3 and the other side of the fork will touch the designated log placement tabs. The other end of the logs rests on the smooth area on Log #7 as noted in Figure 11.7. See Figure 11.8.



Figure 11.8 Place Log #5

8. Install Log #4 by placing the forked end down onto the base pan and leaning the top end of Log #4 back so that it is resting on Log #3. The forked end should contact the two log placement tabs. See Figure 11.9.



Figure 11.9 Place Log #4

9. Place lava rock onto areas of the base pan to fill in around the logs as desired. It is acceptable to completely cover the basepan. DO NOT cover burner, gaps behind burner or air tab. DO NOT block the space in front of the pilot assembly. See Figure 11.2. Place lava rock in a single layer so no sheet metal is showing. Figure 11.10 shows lava rock properly placed in relation to logs and areas that must be avoided.

WARNING! Risk of Delayed Ignition! DO NOT place lava rock on burner. Place only on top of base pan. Fireplace will not function properly. Delayed ignition may occur.

WARNING! Risk of Fire! DO NOT place lava rock directly in front of the pilot assembly or cover the burner ports.

⚠ WARNING



Delayed Ignition Risk

- Place lava rock according to instructions.
 - Do NOT place lava rock in area in front of pilot or directly on burner.
 - Do NOT place lava rock in a position that they may fall into area in front of pilot.
 - Do NOT use any media other than the lava rock supplied with this kit.
 - Do NOT use more than one bag of lava rock per fireplace.
 - Do NOT exceed one layer of media on base pan.
- Fireplace will not function properly.
Delayed ignition could occur.

⚠ WARNING



Risk of Asphyxiation or Fumes.

- Place media according to instructions.
 - Do NOT place media in area between glass and firebox.
 - Do NOT place media in a position that they may fall into area between glass and firebox.
 - Do NOT use any media other than the media supplied with this fireplace.
- Fireplace will not function properly.
Gas leak could occur.



Figure 11.10 Properly Placed Lava Rock / Location for Mineral Wool

E. Fixed Glass Assembly Removal and Replacement

WARNING! Risk of Asphyxiation! Handle fixed glass assembly with care. Inspect the gasket to ensure it is undamaged and inspect the glass for cracks, chips or scratches.

- **DO NOT** strike, slam or scratch glass.
- **DO NOT** operate fireplace with glass removed, cracked, broken or scratched.
- Replace as a complete assembly.

Removing Fixed Glass Assembly

1. Remove the decorative front.
2. The glass assembly has two upper spring latches and two lower spring latches. See Figure 11.11. Locate the two spring latches that are on the upper left and right of the fireplace.
3. Pull upper spring latch on one side forward to release glass assembly while supporting glass assembly with opposite hand. Repeat for the other upper spring latch always taking care to support the glass assembly with one hand.
4. Grasp glass on the upper right and left sides and remove glass assembly by lifting “up” and “out”.

Note: Observe the presence of a space or gap between the glass latch and the front of the appliance where the bottom of the glass assembly is positioned. This gap is designed for positive placement when replacing the glass assembly. See Figure 11.11.

Replacing Fixed Glass Assembly

The bottom glass latches have been designed to create a small gap between the glass clip and the face of the appliance. See Figure 11.11.

1. Install the bottom of the glass assembly so that the two tabs on the bottom of the glass latch engage the gap. By tilting the top of the glass towards the face of the appliance, tension will be applied to the bottom two glass latches. Use one hand to support the glass at all times.
2. Fasten the two upper glass latches, one at a time, by pulling out and downward into position on the glass assembly. Use one hand to support the glass at all times.
3. Verify that the top two glass latches are engaged by visually verifying that glass latches have engaged both left and right tabs on the glass frame.
4. Verify the bottom two glass latches have engaged the glass frame tabs by grasping the bottom of the glass frame assembly and pulling the glass frame assembly “away” from the face of the appliance and “release” the glass frame. The spring action of the clips will “pull” the glass frame assembly towards the face of the appliance if bottom clips are properly engaged. If the glass frame assembly does not pull back towards the face of the appliance, repeat steps 1-4.

WARNING! Risk of Explosion! Risk of Asphyxiation! Glass latches **MUST** be properly engaged. Inspect glass seal before installing decorative front. Gas could leak!

5. Reinstall decorative barrier front.

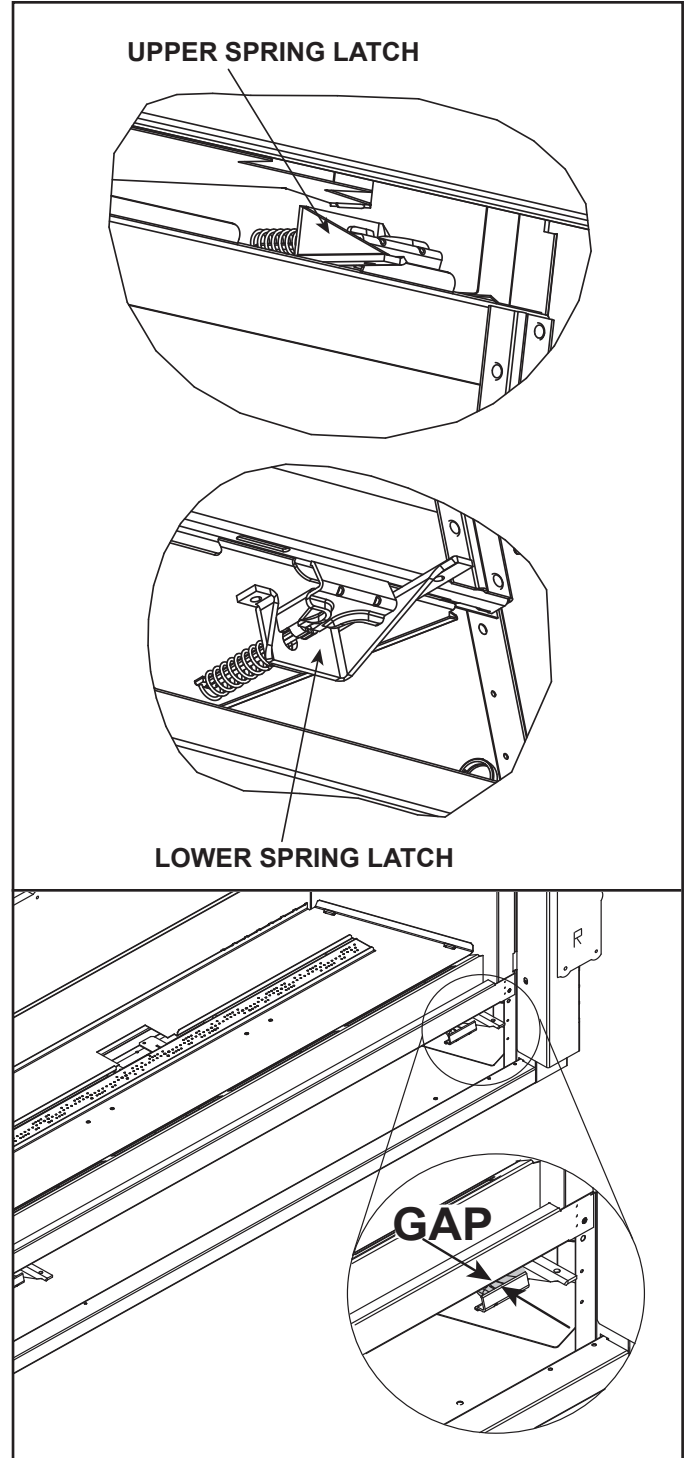

Figure 11.11 Fixed Glass Assembly

F. Install Decorative Barrier Front

WARNING! Risk of Fire! Install *ONLY* decorative barrier fronts approved by Hearth & Home Technologies. Unapproved decorative barrier fronts could cause fireplace to overheat.

IMPORTANT! This fireplace requires an installed decorative barrier front to prevent direct contact with the hot viewing glass. **DO NOT** operate the fireplace with the barrier removed.

Contact your dealer or Hearth & Home Technologies if the barrier is not present or help is needed to properly install one.

For more information refer to the instructions supplied with your decorative barrier front.

12 Reference Materials

A. Vent Components Diagrams

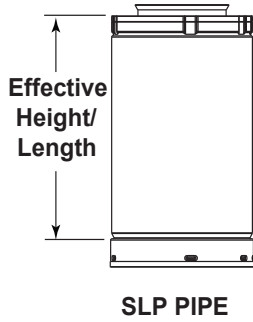
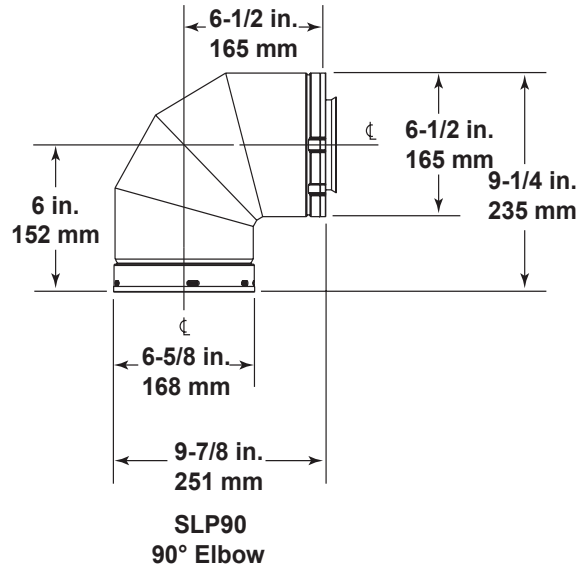
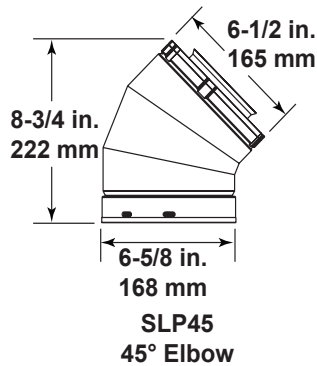

Effective Height/Length		
Pipe	inches	mm
SLP4	4	102
SLP6	6	152
SLP12	12	305
SLP24	24	610
SLP36	36	914
SLP48	48	1219
SLP6A	2 - 6	51 - 152
SLP12A	2 - 12	51 - 305

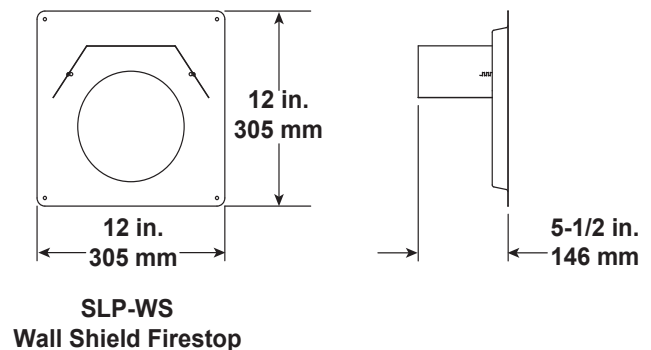
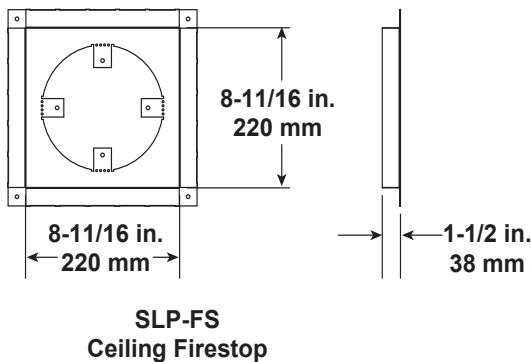
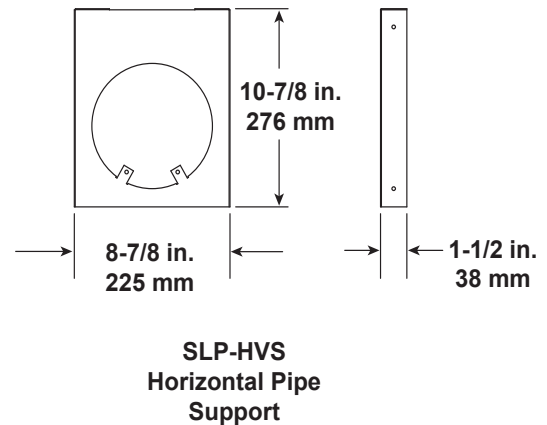
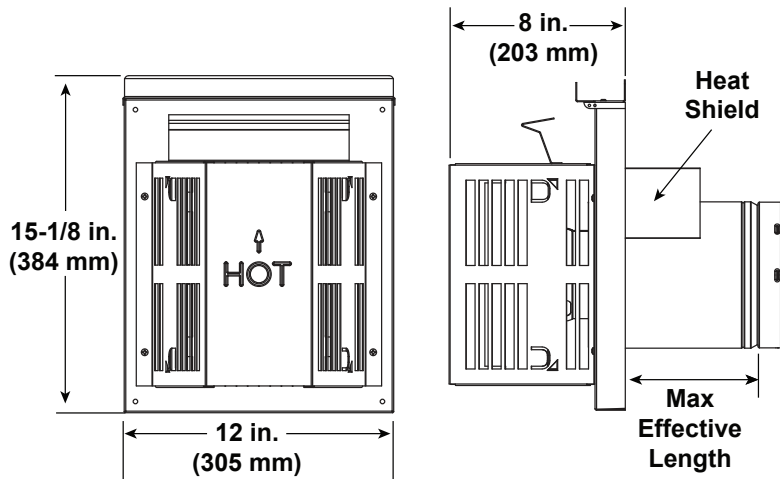

Figure 12.1 SLP Series Vent Components

A. Vent Components Diagrams (continued)

Note: Heat shields MUST overlap by a minimum of 1-1/2 in. (38 mm). The heat shield is designed to be used on a wall 4 in. to 7-1/4 in. (102 mm to 184 mm) thick. If wall thickness is less than 4 in. (102 mm) the existing heat shields must be field trimmed. If wall thickness is greater than 7-1/4 in. (184 mm) a DVP-HSM-B will be required.



SLP-TRAP
Horizontal Termination Cap

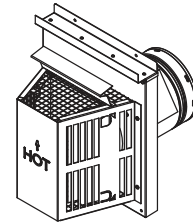

Term Cap	Minimum Effective Length	Maximum Effective Length
Trap1	3-1/8 in.	4-3/4 in.
	79 mm	121 mm
Trap2	5-1/4 in.	9-1/4 in.
	133 mm	235 mm

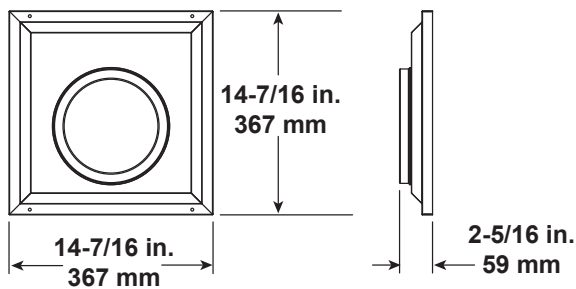

SLP-WT-BK
Wall Thimble-Black

Figure 12.2 SLP Series Vent Components

A. Vent Components Diagrams (continued)

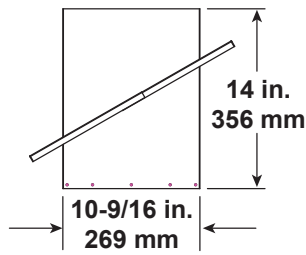

SLP-CCS-BK
Cathedral Ceiling
Support Box-Black

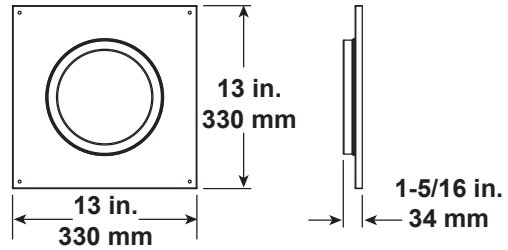

SLP-DCF-BK
Ceiling Firestop
Black

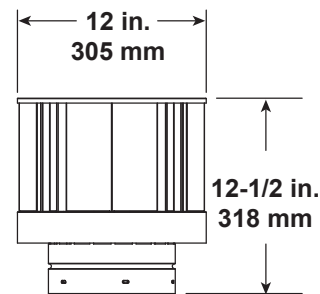

SLP-TVHW
Vertical
Termination Cap

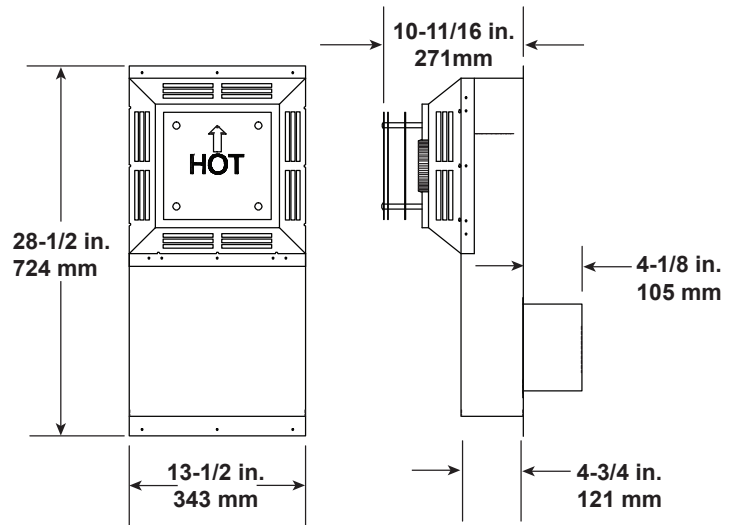

SLK-SNKD
Snorkel
Termination Cap

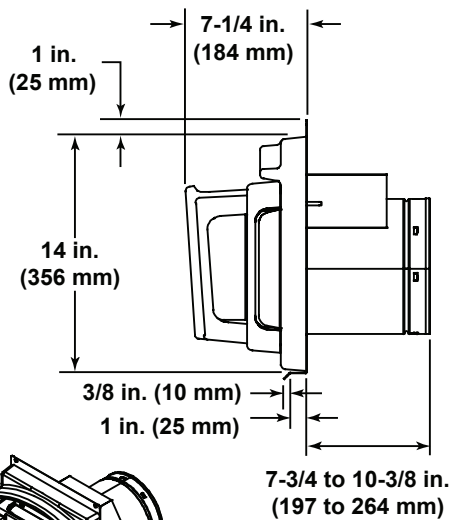

DVP-FBHT
Horizontal
Termination Cap
(SL-2DVP Required)

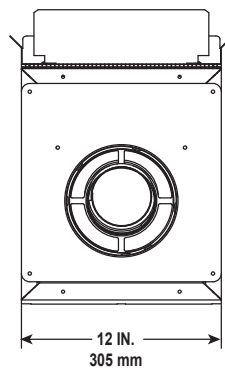

SLP-TB1
Basement Vent Cap

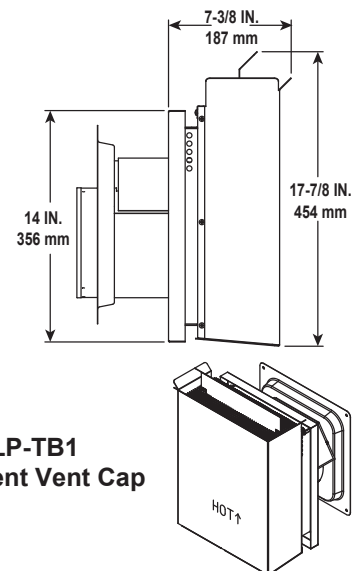

Figure 12.3 SLP Series Vent Components

A. Vent Components Diagrams (continued)

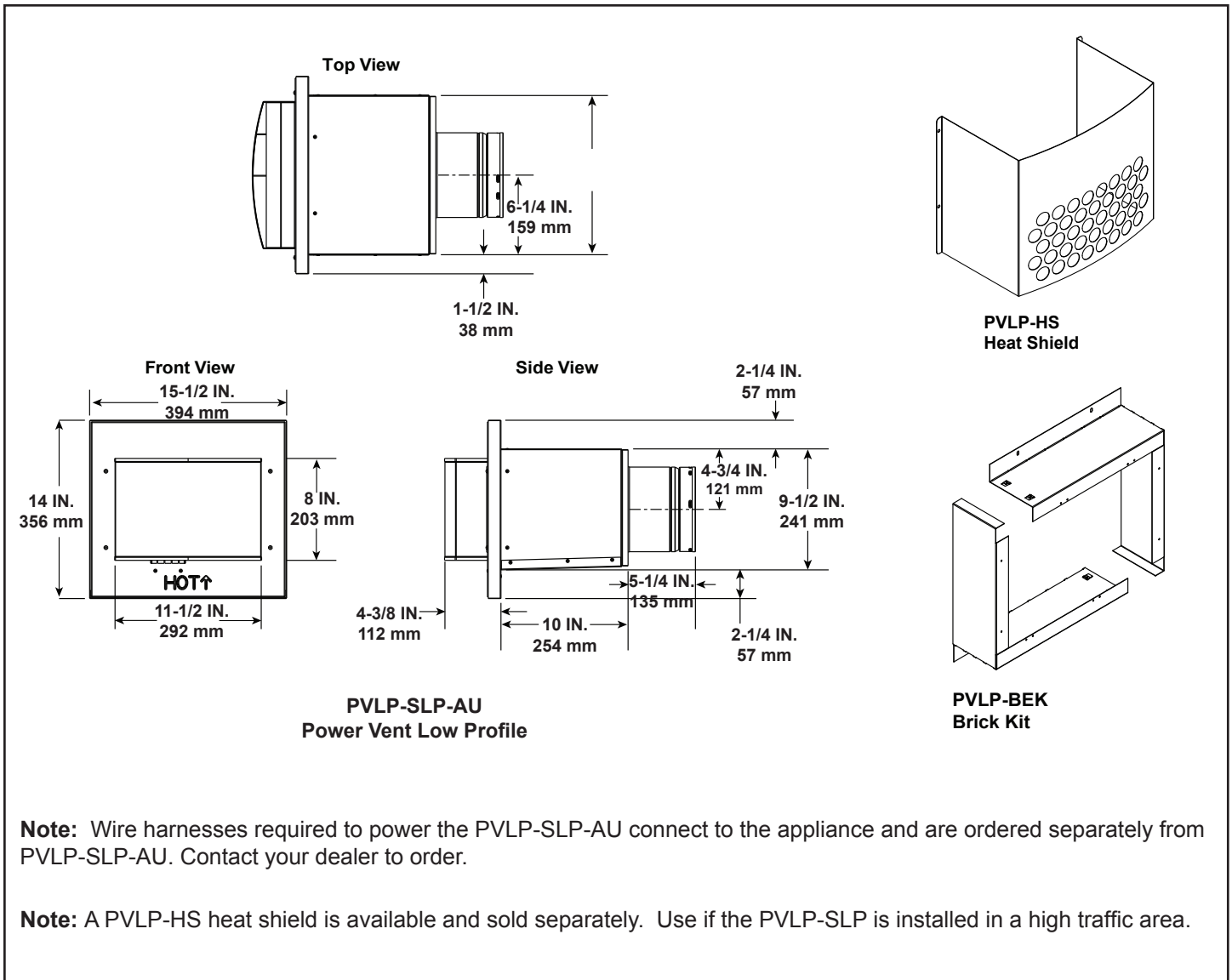

Figure 12.4 PVLP-SLP-AU Vent Components

B. Accessories

Install approved accessories per instructions included with accessories. Contact your dealer for a list of approved accessories.

It is recommended that optional accessories are installed prior to installation of finishing material. The lower cover panel is removable and provides access for installation of the remote control upgrades. If finishing material is already installed, the optional accessories must be installed by removing the base pan, burner and valve assembly. Use only Hearth & Home Technologies-approved optional accessories with this appliance.

WARNING! Risk of Fire and Electric Shock! Use ONLY Hearth & Home Technologies-approved optional accessories with this appliance. Using non-listed accessories could result in a safety hazard and will void the warranty.

Remote Controls, Wall Controls and Wall Switches

After a qualified service technician has installed the remote control, wall control or wall switch, follow the instructions supplied with the control installed to operate your fireplace:

For safety:

- Install a switch lock or a wall/remote control with child protection lockout feature.
- Keep remote controls out of reach of children.

See your dealer if you have questions.

Optional Heat Management Systems

After a service technician has installed the Heat-Zone® -240V or Passive Heat Kit, follow the instructions supplied with the kit for operation. Contact your dealer if you have questions.

Note: Optional heat management systems kit must be installed while the top of the appliance is accessible.

Optional Fan

After a qualified service technician has installed the fan, follow the instructions supplied with the fan kit to operate your fan. Contact your dealer if you have questions.

Note: The optional fan can not be used with the Passive Heat kit.

Optional Glass Refractory Kit

An optional glass refractory kit is available for B41L-AU model. Follow the instructions supplied with the kit for installation. Contact your dealer if you have questions.

Optional Log Kits

Traditional or Driftwood Log kits are available for B41L-AU model. Follow the instructions supplied with the kit for installation. Contact your dealer if you have questions.

Optional Stones Kit

An optional stones kit is available for use with the B41L-AU model.

Available Media Options:

This appliance is approved for use with the following:

- Decorative Glass Media

Follow the instruction supplied with the kit for installation. Contact your dealer if you have questions.

Hearth & Home Technologies
7571 215th Street West, Lakeville, MN 55044
www.hearthnhome.com

Please contact your Hearth & Home Technologies dealer with any questions or concerns.
For the location of your nearest Hearth & Home Technologies dealer,
please visit www.hearthnhome.com.

Printed in U.S.A. - Copyright 2020